

R-TYPE® Secondary Belt Cleaner

Reversing Secondary Belt Cleaner

The Flexco R-Type® Secondary Belt Cleaner is recommended for reversing belts and is designed to be positioned just off the head pulley to remove carryback from the belt. Stand alone, or when used in conjunction with a precleaner, the R-Type cleaner is a reliable choice for maintaining a highly efficient cleaning system.

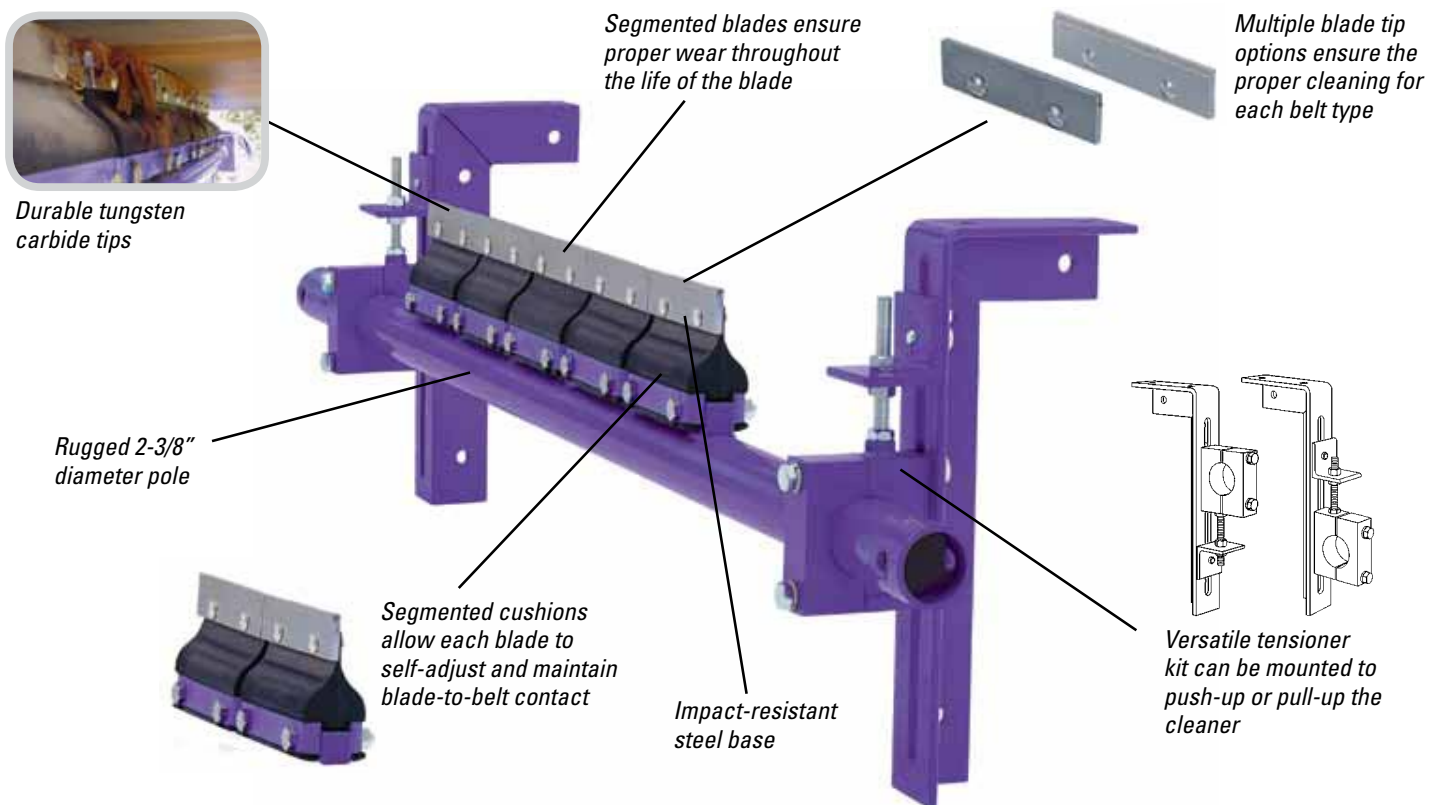

Features and Benefits

- **Cleaning efficiency of metal blades.** The thin, hard edges of the metal blades deliver high cleaning efficiency and long wear life.
- **Works with Flexco mechanical splices.** The C-Tip tungsten carbide blades are impact-resistant, and the spring cushion allows them to move away from a passing splice without damage and with minimal cleaning disruption. V-Tips can be used only on vulcanized belts.
- **A complete cleaning system.** When the R-Type is teamed with a precleaner the system provides maximum cleaning power for tough applications.
- **Fits most conveyor structures.** Available for belt widths from 18" to 72" (450 mm to 1800 mm).

R-TYPE® Secondary Belt Cleaner

Specifications and Guidelines

Maximum Belt Speed

1000 FPM (5 M/sec)

Temperature Rating

-30° F to 180° F (-35° C to 82° C)

Usable Blade Wear Length

3/8" (9mm)

Blade Material

Impact resistant, long-lasting tungsten carbide (C-Tips for mechanical fasteners, V-Tips for vulcanized belts)

Available for Belt Widths

18" to 72" (450 to 1800mm)

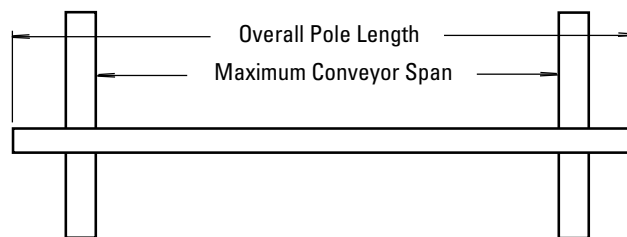

Pole Length

Cleaner size up to 48" (1200mm) + 30" (750mm)

Cleaner size 54" and up (1350mm) + 34" (850mm)

Maximum Conveyor Span

Cleaner size up to 48" (1200mm) + 25" (625mm)

Cleaner size 54" and up (1350mm) + 29" (725mm)

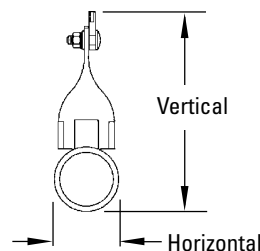

Horizontal Clearance Required

4" (100mm)

Vertical Clearance Required

8" (200mm)

Ordering Information

R-Type® Reversing with C-Tips*			
Belt Width		Ordering Number	Item Code
in.	mm		
18	450	RC18	74618
24	600	RC24	74619
30	750	RC30	74620
36	900	RC36	74621
42	1050	RC42	74622
48	1200	RC48	74623
54	1350	RC54	74624
60	1500	RC60	74625
72	1800	RC72	74626

*NOTE: C-Tips can be used on mechanically spliced and vulcanized belts.

R-Type Reversing with V-Tips*			
Belt Width		Ordering Number	Item Code
in.	mm		
18	450	RV-18	78402
24	600	RV-24	78403
30	750	RV-30	78404
36	900	RV-36	78405
42	1050	RV-42	78406
48	1200	RV-48	78407
54	1350	RV-54	78408
60	1500	RV-60	78409
72	1800	RV72	74641

*NOTE: V-Tips can be used ONLY on vulcanized belts.

Replacement Tips	
Ordering Number	Item Code
ICT6	74535
RSA150	73628

Lead time: 1 working day

Tips Required per Cleaner Size									
in.	18	24	30	36	42	48	54	60	72
mm	450	600	750	900	1050	1200	1350	1500	1800
C-Tips or V-Tips Required	3	4	5	6	7	8	9	10	12



2525 Wisconsin Avenue • Downers Grove, IL 60515-4200 U.S.A.
Tel: (630) 971-0150 • Fax: (630) 971-1180 • E-mail: info@flexco.com • Web: www.flexco.com

Australia: 61-2-9680-3322 • China: 86-21-33528388 • England: 44-1274-600-942 • Germany: 49-7428-9406-0
India: 91-44-4354-2091 • Mexico: 52-55-5674-5326 • Singapore: 65-6281-7278 • South Africa: 27-11-608-4180

©2011 Flexible Steel Lacing Company. 06/11. For Reorder: X2398

Authorized Distributor:

