

# P-TYPE® Secondary Belt Cleaner

## Reliable Secondary Belt Cleaner

The Flexco P-Type® Secondary Belt Cleaner is compact and designed to be positioned just off the head pulley to remove carryback from the belt. Stand alone, or when used in conjunction with a precleaner, the P-Type cleaner is a reliable choice for maintaining a highly efficient cleaning system.

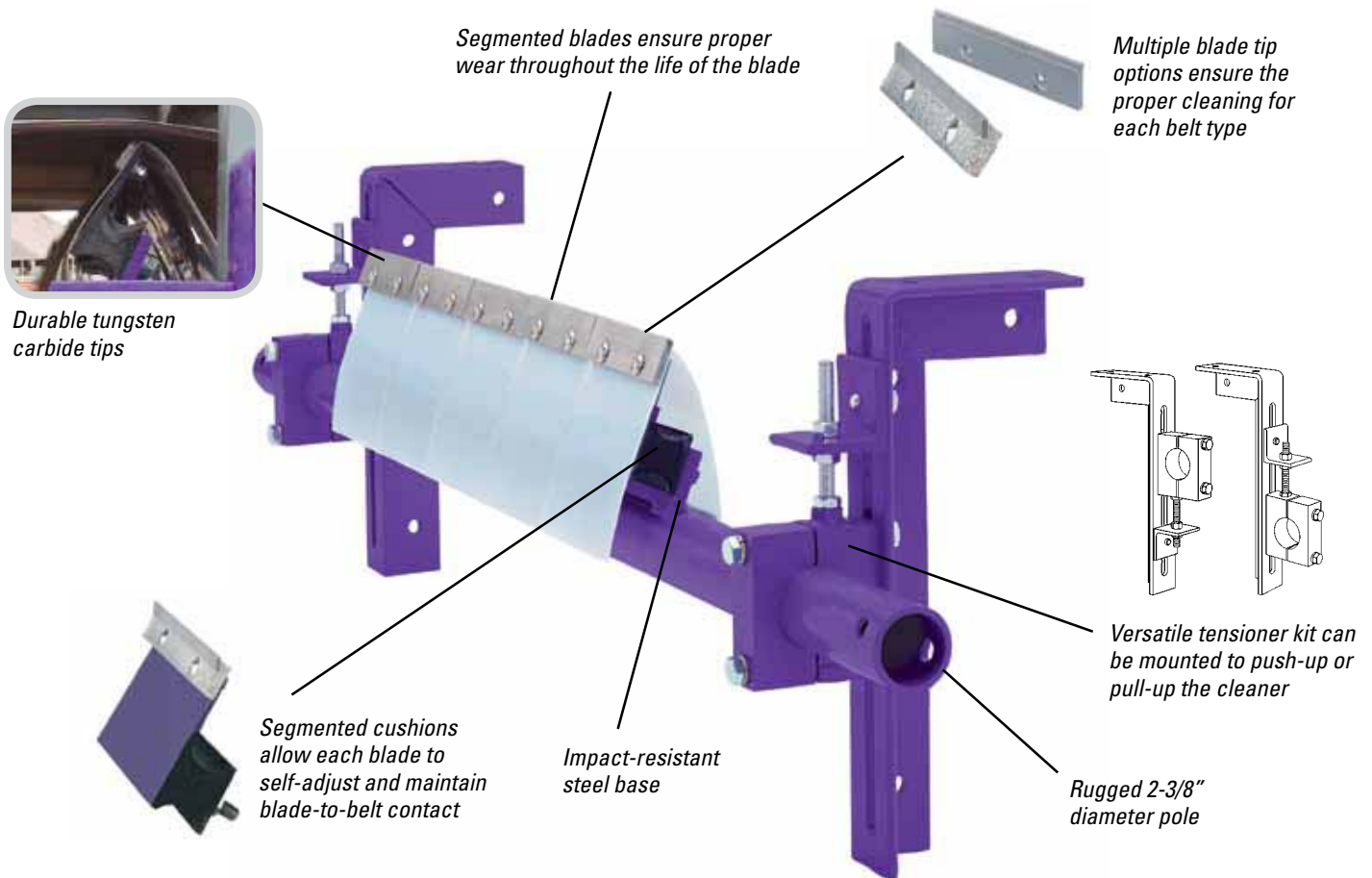

### Features and Benefits

- **Cleaning efficiency of metal blades.** The thin, hard edges of the metal blades deliver high cleaning efficiency and long wear life.
- **Works with Flexco mechanical splices.** The C-Tip tungsten carbide blades are impact-resistant, and the spring cushion allows them to move away from a passing splice without damage and with minimal cleaning disruption. V-Tip can be used only on vulcanized belts.
- **A complete cleaning system.** When the P-Type is teamed with a primary cleaner the system provides maximum cleaning power for tough applications.
- **Fits most conveyor structures.** Available for belt widths from 18" to 72" (450 mm to 1800 mm).

# P-TYPE® Secondary Belt Cleaner

## Specifications and Guidelines

### Maximum Belt Speed

1000 FPM (5 M/sec)

### Temperature Rating

-30° F to 180° F (-35° C to 82° C)

### Usable Blade Wear Length

3/8" (9 mm)

### Blade Material

Impact resistant, long-lasting tungsten carbide (C-Tip for mechanical fasteners, V-Tips for vulcanized belts)

### Available for Belt Widths

18" to 72" (450 to 1800mm)

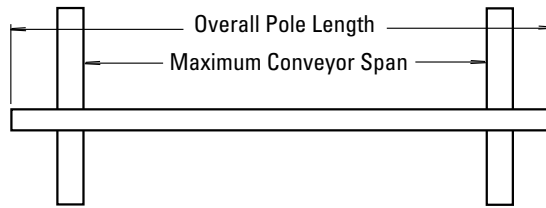

### Pole Length

Cleaner size up to 48" (1200mm) + 30" (750mm) / Cleaner size 54" and up (1350mm) + 34" (850mm)

### Maximum Conveyor Span

Cleaner size up to 48" (1200mm) + 25" (625mm) / Cleaner size 54" and up (1350mm) + 29" (725mm)

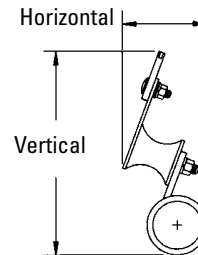

### Horizontal Clearance Required

4" (100mm)

### Vertical Clearance Required

8" (200mm)

## Ordering Information

### P-Type® Secondary with C-Tips\*

Belt Width	Ordering Number	Item Code
in. mm		
18 450	PC18	74566
24 600	PC24	74567
30 750	PC30	74568
36 900	PC36	74569
42 1050	PC42	74570
48 1200	PC48	74571
54 1350	PC54	74572
60 1500	PC60	74573
72 1800	PC72	74574

\*NOTE: C-Tips can be used on mechanically spliced and vulcanized belts. P-Type cleaners come standard with Select Set™ Tensioners.

### P-Type® Secondary with V-Tips\*

Belt Width	Ordering Number	Item Code
in. mm		
18 450	PV-18	78453
24 600	PV-24	78415
30 750	PV-30	78417
36 900	PV-36	78419
42 1050	PV-42	78421
48 1200	PV-48	78423
54 1350	PV-54	78454
60 1500	PV-60	78455
72 1800	PV72	73438

\*NOTE: V-Tips can be used ONLY on vulcanized belts. P-Type cleaners come standard with Select Set™ Tensioners.

### Replacement Tips

Ordering Number	Item Code
ICT6	74535
PVT6	73156

Lead time: 1 working day

### Tips Required per Cleaner Size

in.	18	24	30	36	42	48	54	60	72
mm	450	600	750	900	1050	1200	1350	1500	1800
C-Tips or V-Tips Required	3	4	5	6	7	8	9	10	12

## Additional Information

For size restricted applications, see the P-Type LS (Limited Space) Sell Sheet X2479.

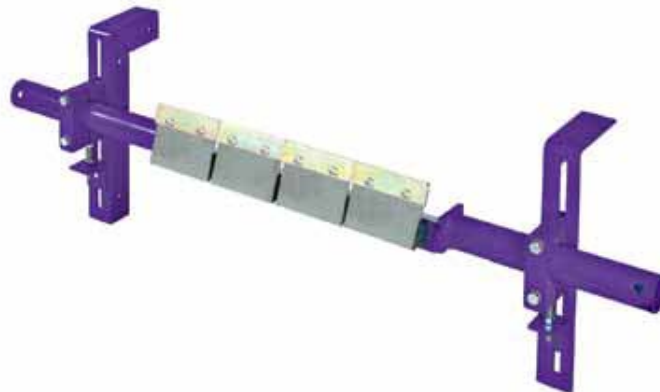

Authorized Distributor:



2525 Wisconsin Avenue • Downers Grove, IL 60515-4200 U.S.A.  
Tel: (630) 971-0150 • Fax: (630) 971-1180 • E-mail: info@flexco.com • Web: www.flexco.com

Australia: 61-2-9680-3322 • China: 86-21-33528388 • England: 44-1274-600-942 • Germany: 49-7428-9406-0  
India: 91-44-4354-2091 • Mexico: 52-55-5674-5326 • Singapore: 65-6281-7278 • South Africa: 27-11-608-4180

©2011 Flexible Steel Lacing Company. 06/11. For Reorder: X2397

