

MMP

Medium-Duty Precleaner

Extra Cleaning Power for Tough Jobs

The MMP Medium-Duty Precleaner tackles those tough applications where the standard-duty precleaner is not sturdy enough but the heavy-duty cleaner is overkill. The MMP is built tough with a heavy-duty pole, a larger, powerful blade and a beefy dual tensioning system. Yet installation is simple, maintenance is quick, and bottom line – the cleaning job is excellent.

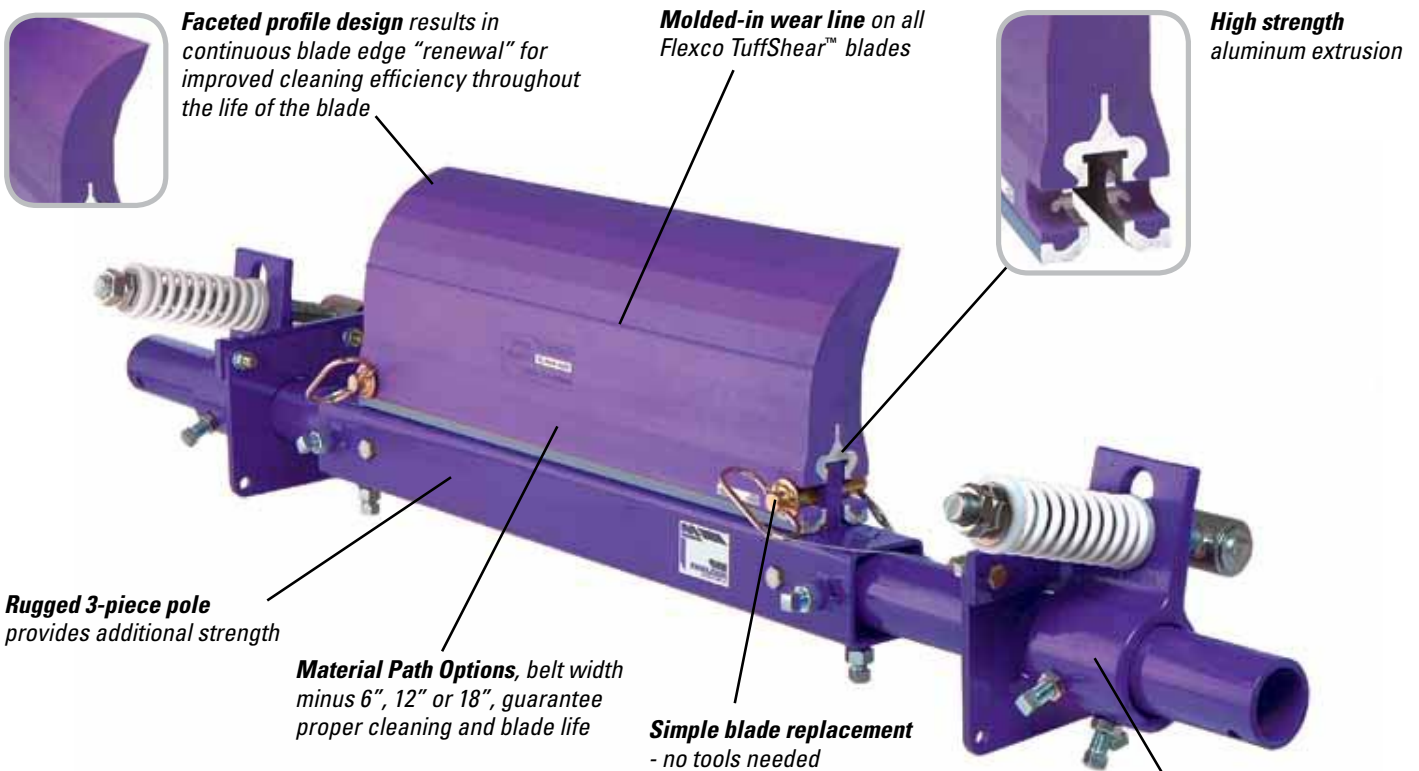

Features and Benefits

- **Compact and versatile.** Requires only 4" (100 mm) of horizontal clearance for installation. Pole length is belt width plus 54" (1350 mm) to fit varying conveyor or chute wall widths. Pole extenders are available for extended length requirements.
- **Works with Flexco and other mechanical splices.** The spring tensioner quickly moves the blade away from the belt when a splice passes. The polyurethane blade easily glides over the splice without damage and with minimal cleaning disruption.
- **Made for mining conveyors.** Made from heavy-duty steel with corrosion-resistant powder coating, the MMP is available for belt widths from 24" to 84" (600 to 2100 mm). Special sizes are available upon request.
- **Complete cleaning system.** When teamed with our MHS Secondary Cleaner, it makes up a system that delivers maximum cleaning power. If extra water is present, the MDWS DryWipe can be added.



MMP Medium-Duty Precleaner

Specifications and Guidelines

- **Maximum Belt Speed**
1000 FPM (5 M/sec)
- **Temperature Rating**
-30°F to 180°F (-35°C to 82°C)
- **Minimum Pulley Diameter**
16" (400 mm)
- **Blade Height**
10" (250 mm)
- **Useable Blade Wear Length**
6" (150 mm)
- **Blade Material**
Urethane 83 durometer (proprietary blend for abrasion resistance and long wear)
- **Available for Belt Widths**
24" to 84" (600 to 2100mm)
- **Horizontal Clearance Required**
4" (100mm)
- **Vertical Clearance Required**
13" (325mm)
- **Pole Length**
Cleaner size + 54" (1350mm)
- **Maximum Conveyor Span**
Cleaner size + 42" (1050mm)

Pole Location Specs

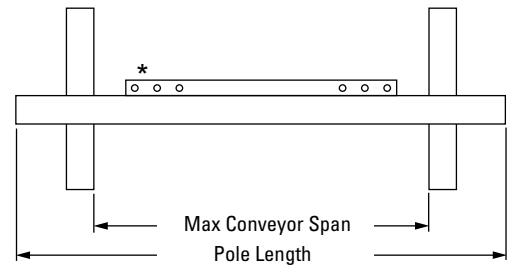
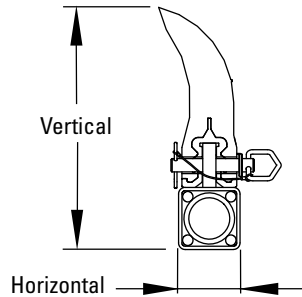
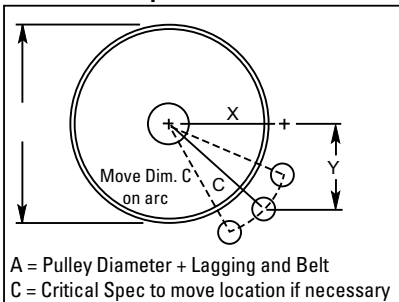

Pole Location Chart

A	X	Y	C	A	X	Y	C	A	X	Y	C
16"	8-1/8"	12"	14-1/2"	27"	14-1/8"	12"	18-1/2"	38"	19-3/4"	12"	23-1/8"
17"	8-3/4"	12"	14-7/8"	28"	14-5/8"	12"	18-7/8"	39"	20-3/8"	12"	23-5/8"
18"	9-1/4"	12"	15-1/8"	29"	15-1/4"	12"	19-3/8"	40"	20-3/4"	12"	24"
19"	9-3/4"	12"	15-1/2"	30"	15-5/8"	12"	19-3/4"	41"	21-3/8"	12"	24-1/2"
20"	10-3/8"	12"	15-7/8"	31"	16-1/8"	12"	20-1/8"	42"	21-3/4"	12"	24-7/8"
21"	11"	12"	16-1/4"	32"	16-3/4"	12"	20-5/8"	43"	22-3/8"	12"	25-3/8"
22"	11-1/2"	12"	16-5/8"	33"	17-1/4"	12"	21"	44"	22-3/4"	12"	25-3/4"
23"	12"	12"	17"	34"	17-3/4"	12"	21-3/8"	45"	23-3/8"	12"	26-1/4"
24"	12-5/8"	12"	17-3/8"	35"	18-1/4"	12"	21-7/8"	46"	23-7/8"	12"	26-3/4"
25"	13-1/8"	12"	17-3/4"	36"	18-3/4"	12"	22-1/4"	47"	24-3/8"	12"	27-1/8"
26"	13-5/8"	12"	18-1/8"	37"	19-3/8"	12"	22-3/4"	48"	24-7/8"	12"	27-5/8"

Ordering Information

MMP Precleaner - Belt Width Minus 6"

Belt Width	Blade Width	Ordering Number	Item Code
in.	mm		
24	600	MMP-624	76450
30	750	MMP-630	76451
36	900	MMP-636	76452
42	1050	MMP-642	76453
48	1200	MMP-648	76454
54	1350	MMP-654	76455
60	1500	MMP-660	76456
72	1800	MMP-672	76457
84	2100	MMP-684	76798

MMP Precleaner - Belt Width Minus 12"

Belt Width	Blade Width	Ordering Number	Item Code
in.	mm		
30	750	MMP-1230	76551
36	900	MMP-1236	76552
42	1050	MMP-1242	76553
48	1200	MMP-1248	76554
54	1350	MMP-1254	76555
60	1500	MMP-1260	76556
72	1800	MMP-1272	76557
84	2100	MMP-1284	76799

TuffShear™ Replacement Blades

Blade Width	Ordering Number	Item Code	
in.	mm		
18	450	TRB18	76485
24	600	TRB24	76486
30	750	TRB30	76487
36	900	TRB36	76488
42	1050	TRB42	76489
48	1200	TRB48	76490
54	1350	TRB54	76491
60	1500	TRB60	76492
66	1650	TRB66	76493
72	1800	TRB72	76494
78	1950	TRB78	76697

Other blade sizes available upon request.



2525 Wisconsin Avenue • Downers Grove, IL 60515-4200 U.S.A.
Tel: (630) 971-0150 • Fax: (630) 971-1180 • E-mail: info@flexco.com • Web: www.flexco.com

Australia: 61-2-9680-3322 • China: 86-21-33528388 • England: 44-1274-600-942 • Germany: 49-7428-9406-0
India: 91-44-4354-2091 • Mexico: 52-55-5674-5326 • Singapore: 65-6281-7278 • South Africa: 27-11-608-4180

©2011 Flexible Steel Lacing Company. 06/11. For Reorder: X2395

Authorized Distributor:

