

Motorized Pulleys for belt conveyors

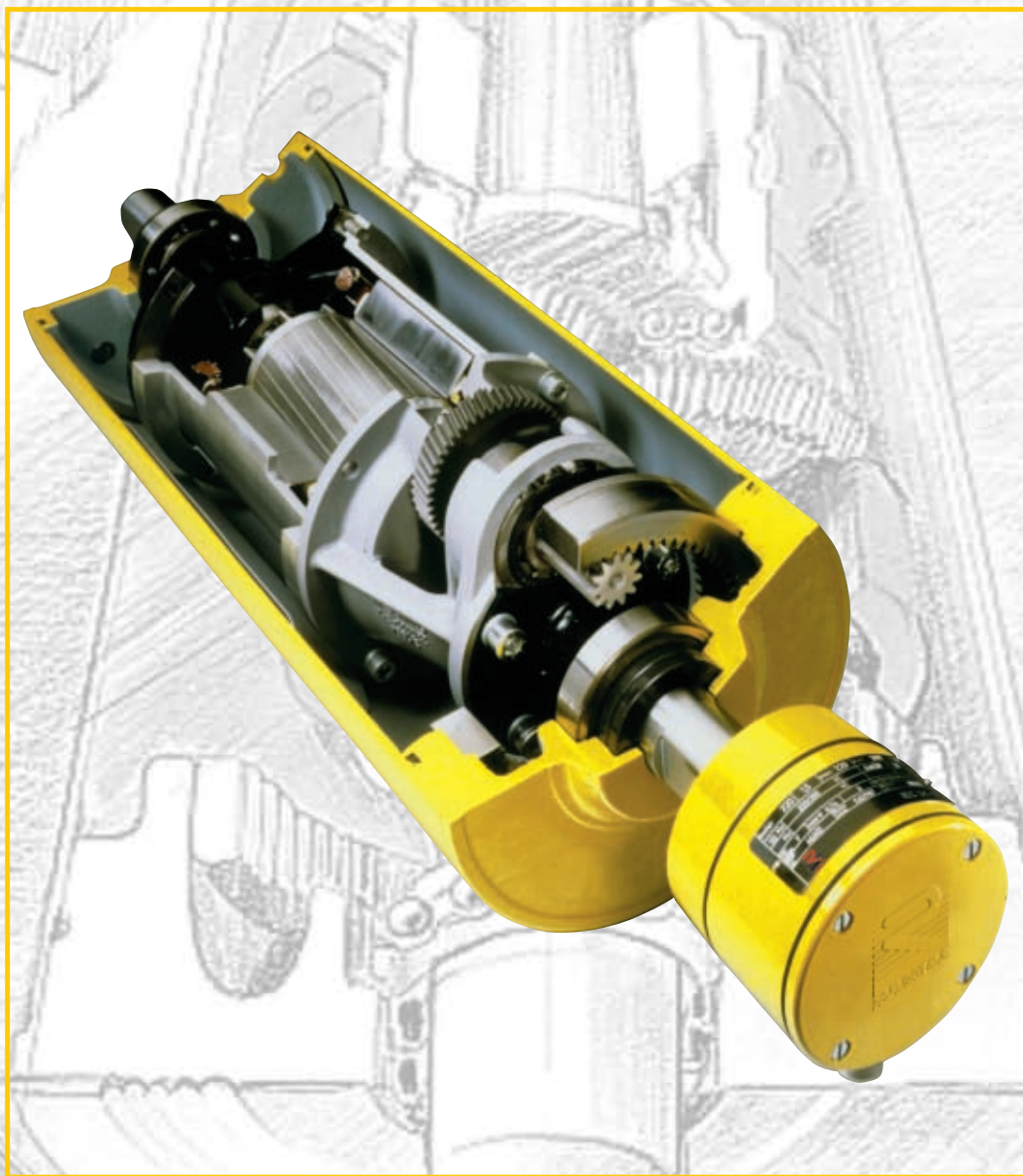

6° ed. MOT BU RULMECA GERMANY 05/12

BULK HANDLING



Crushing & Screening – A motorized pulley in its right element!



RULMECA GERMANY GmbH, Aschersleben - the production place of Rulmeca Motorized pulleys, belt Pulleys and Heavy Duty Rollers

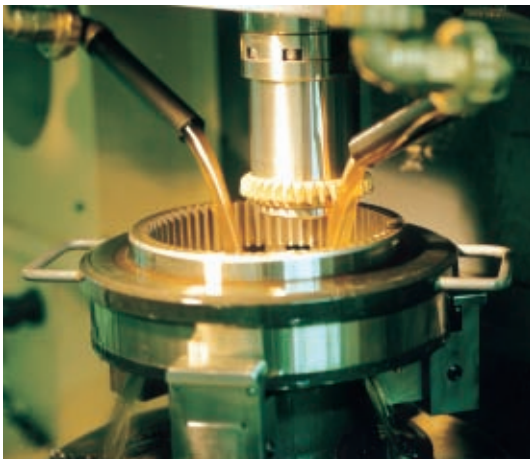

CNC gear shaping machine



Assembly of Rulmeca Motorized Pulleys



Electric motor production

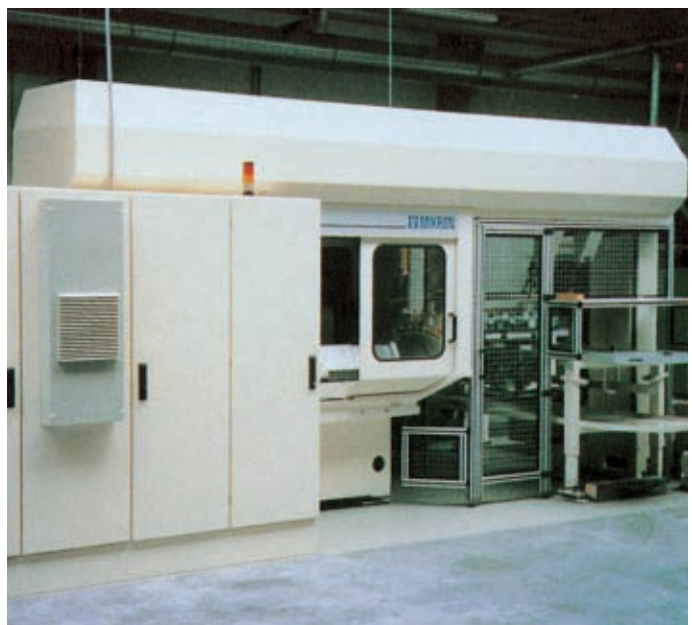

CNC gear hobbing machine



Table of Contents

Rulmecca Motorized Pulleys - Opening words.....	1
General description	2
Application photos.....	3
Features and Benefits of Rulmecca Motorized Pulleys.....	4
Application photos.....	5
Photo of cut-through Motorized Pulley	6
Form for “information needed when ordering”	7
Motorized Pulley 138E specifications.....	8-13
Motorized Pulley 165E specifications.....	14-19
Motorized Pulley 220M & 220H specifications	20-28
Application photos.....	29
Motorized Pulley 320L, 320M & 320H specifications.....	30-38
Application photos.....	39
Motorized Pulley 400L, 400M & 400H specifications.....	40-48
Application photos.....	49
Motorized Pulley 500L, 500M & 500H specifications.....	50-56
Application photos.....	57
Motorized Pulley 500H specifications	58-59
Motorized Pulley 630M & 630H specifications	60-63
Motorized Pulley 800M & 800H; HD specifications.....	64-67
Part lists & sectional drawings - 500H, 630M, 630H, 800M & 800H; HD.....	68-70
Motorized Pulley 1000HD specifications and drawings.....	71-74
Application photos.....	75-76
Special Environmental Conditions.....	77-78
Power calculation - BULK handling	79
Application worksheet - Bulk Materials Handling Motorized Pulley.....	80
Technical precautions for Design, Installation and Maintenance	81-92
Application photo	93
International Protection - IP ratings.....	94
Application photos.....	95
Oil contents and oil types.....	96-97
Electrical Connection Diagrams - 138E - 1000HD	98-100



Rulmecca Motorized Pulleys: your reliable partner

The Rulmecca Motorized Pulleys presented in this catalogue have a long history to tell.

It goes back to the 1950's when the product was developed in Germany and Denmark as an efficient belt conveyor drive solution.

Since the early 90's the research & development, engineering and manufacturing of the Motorized Pulley range was centralized in Aschersleben, Germany, at what is today the Rulmecca Germany GmbH plant.

RULMECCA is a family owned, worldwide Group of Companies, with headquarters in Italy and specialising in the development, production and sales of belt conveyor rollers/idlers, motorized pulleys, fabricated pulleys and other components for the global bulk handling industry.

Rulmecca are working internationally with leading OEM's, Engineering Companies and End Users supplying products into major applications within the handling of bulk materials such as; coal and lignite

mining, cement, quarries, tunnelling, power plants installation, ports, salt and fertilisers, sugar plants, recycling and demolition, crushing and screening etc...

More than half a century of experience in supplying high quality and reliable belt conveyor solutions for bulk material handling equipment is at your disposal.

www.rulmecca.com

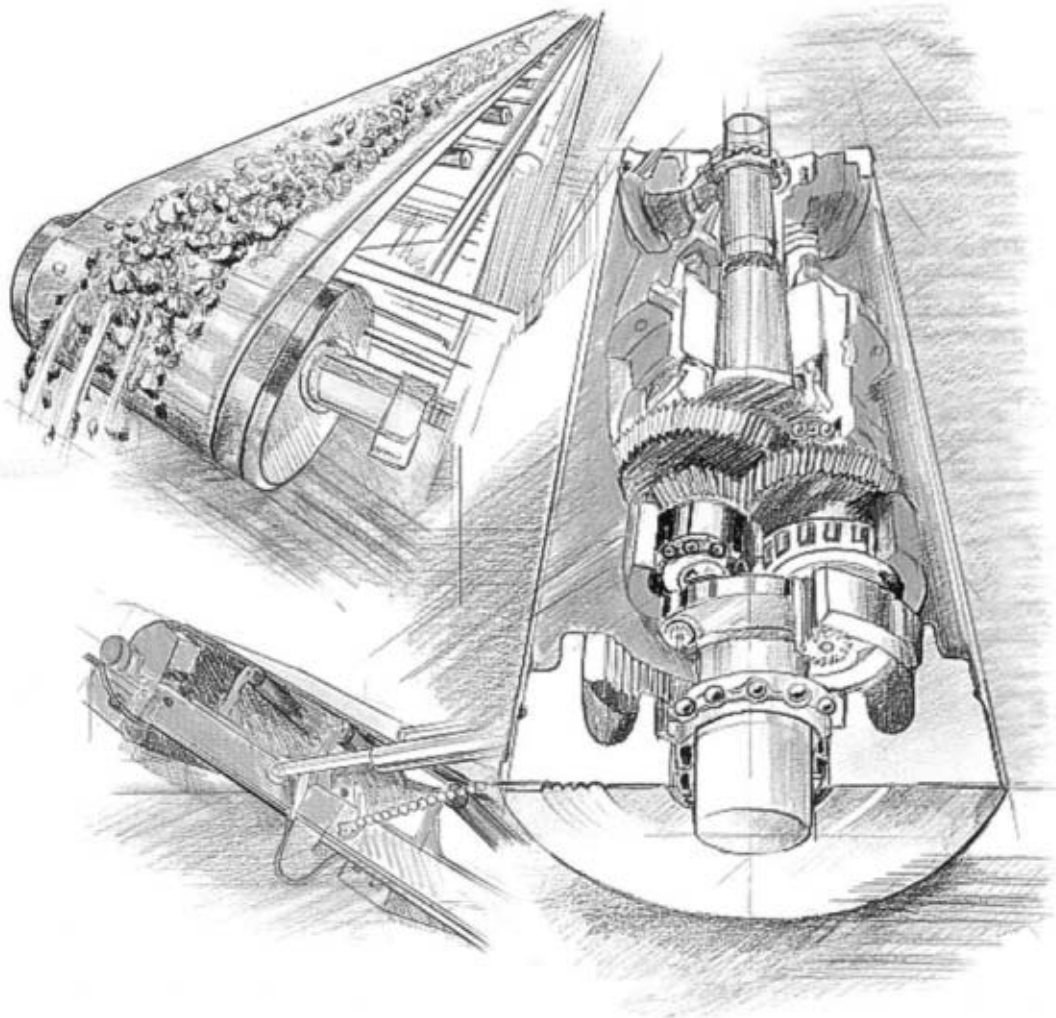



General description

The Rulmecca Motorized Pulley was first produced in 1953 specifically for use on conveyors belt applications.

The aim was to produce a compact, hermetically sealed, highly efficient conveyor drive unit that would be unaffected by dust, water, oil, grease or other harmful substances. A Motorized Pulley that would be quick and simple to install and require virtually no maintenance.

These aims were achieved and today the Rulmecca Motorized Pulley is considered to be one of the most reliable, effective and safe conveyor drive systems available throughout the world.

The Rulmecca Motorized Pulley is a highly efficient geared motor drive, which is hermetically sealed in a steel cylindrical shell.

The shell, which is normally crowned to ensure belt tracking, is fitted with bearing housings incorporating precision bearings, double lipped oils seals and rotates on a pair of shafts.

The motor stator is fixed to the shafts and the motor winding cables passes through one of the shafts, eliminating the need for slip rings and brushes.

The squirrel cage induction motor, manufactured in steel laminate, is machined concentric to high tolerances and designed to give 200 % starting torque for 3 phase versions.

The rotor pinion is coupled directly to the gearbox.

The gearbox transmits torque to the shell through a geared rim and provides a highly efficient motor, with very little frictional losses.

The Motorized Pulley is oil filled, which acts as a lubricant and coolant. Heat is dissipated through the shell and conveyor belt.

All vital parts are CNC machined!

The Rulmecca Motorized Pulley is supplied as standard with:

- Machined mild steel crowned shell.
- Electric motor manufactured in accordance with IEC 34-1 (EN60034-1), (VDE 0530).
- Class F insulation according to IEC 34-1 (EN60034-1), (VDE 0530).
- Most international voltages.
- Standard voltages supplied with +/-10% tolerance in accordance with IEC 38.
- Factory oil filled and tested.
- Degree of protection IP66/67 (EN60034-5).
- Motorized Pulleys are labelled in compliance with the Safety norm ANSI 535.4 and ISO 3864-2.

Rulmecca Motorized Pulleys are manufactured according to the Council Directives of the European Communities.

The CE-marking is according to Directive 2006/95/EC relating to electrical equipment and according to Directive 2004/108/EC relating to electrical magnetic compatibility and amendments.



Sea-dredged aggregates working in wet, salty and aggressive environment! IP66/67 sealing – a MUST – often with re-greasable seals!

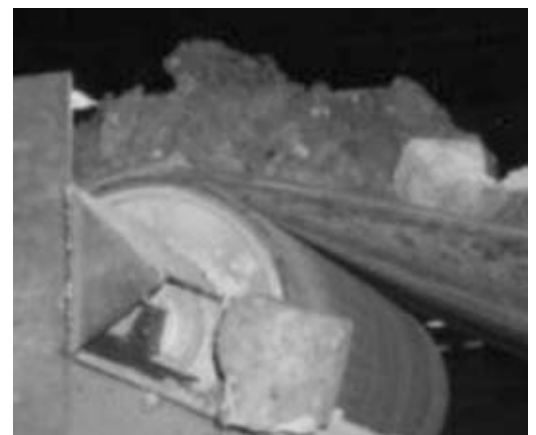
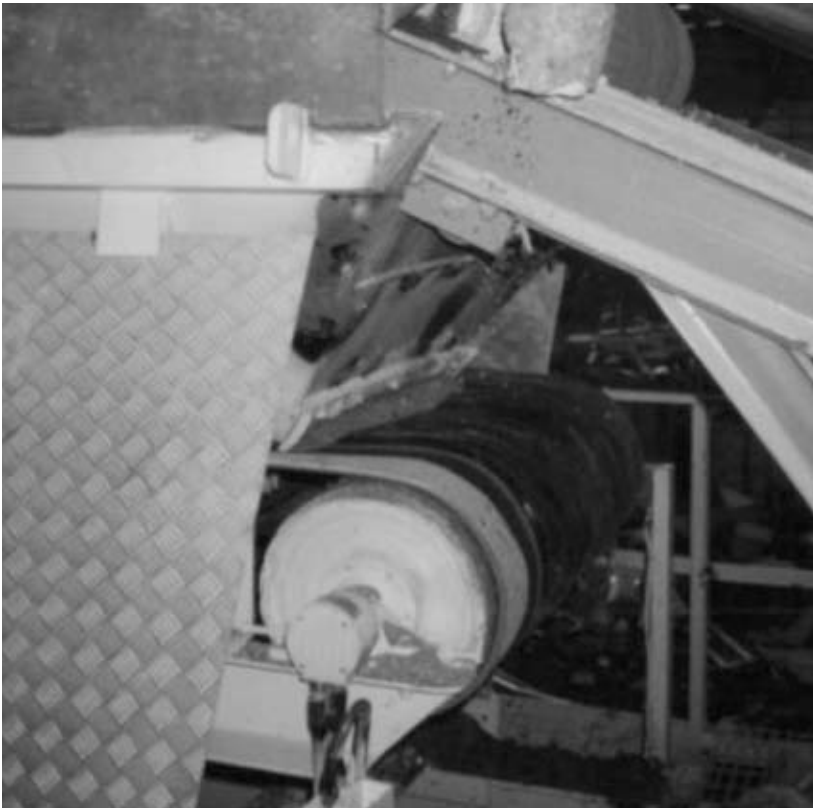

Recycling application benefiting from IP66/67 sealing systems avoiding internal damage from audio or video cassette tapes and aggressive ambient environments containing air or gas of high Ph-values.



Features and Benefits of Rulmeca Motorized Pulleys

Purpose-built design

The Rulmeca Motorized Pulley has been specifically designed for belt conveyors.

Totally enclosed

The motor, gearbox and bearings are totally enclosed and sealed inside a steel shell; therefore they are unlikely to fail due to harmful environmental conditions such as water, dust, grit chemicals, grease, oil, etc.

Space saving design

Because the drive unit and the bearings are mounted inside the Motorized Pulley shell, it takes up much less room than a conventional drive. No need for costly extras like chains, v-belts, couplings, bearings, support structure and special guarding.

Safety

The Rulmeca Motorized Pulley is probably one of the safest drives available because the motor is completely enclosed and the external shafts are always stationary. The only moving external parts are the Motorized Pulley shell and bearing housings.

Low purchasing and installation cost

The Rulmeca Motorized Pulley is quite often less expensive than exposed drives because it has fewer parts. Therefore less conveyor design and parts purchasing costs. It is also much quicker and easier to install - certainly less than a quarter of the time taken to fit an exposed system.

Low maintenance cost

The end user also benefits from the Rulmeca Motorized Pulley, because it requires no maintenance other than the recommended oil change every 20,000 hours and oil seal change every 30,000 hours. In

other words almost 10 years between oil changes based on an 8-hour/day working week. Synthetic oil can be specified to extend the service range up to 50,000 hours.

Efficiency

The Rulmeca Motorized Pulley usually has a much higher efficiency from electrical motor to shell (Pulley face) than conventional drives, because it has fewer frictional losses, and therefore efficiencies of up to 98% can be achieved.

Cleanliness

Because the Rulmeca Motorized Pulley is hermetically sealed it cannot contaminate any conveying materials such as food, electrical components, plastics and other materials that must be kept perfectly clean during handling.

Aesthetic appearance

If installed correctly the Rulmeca Motorized Pulley always looks good. Due to its compact size and smooth lines, quite often the Motorized Pulley is out of sight, because it is hidden within the conveyor frame.

Thermal protection

All three phase Rulmeca Motorized Pulleys are protected by our thermal protection switch. This heat sensitive switch is built into the motor windings to protect the motor from overheating. The thermal protector must be connected to a normally closed circuit.

Weight saving and distribution

Often the Rulmeca Motorized Pulley is lighter than conventional drives and often it is possible to reduce the cost of the conveyor structure, because the weight is evenly distributed within the conveyor frame.

Variable frequency converter

All Rulmeca Motorized Pulleys with 3 phase motors are easily controlled by variable frequency converters working in the 15 Hz to 65 Hz frequency range. See Technical Precautions in the catalogue.

Fewer parts

A Rulmeca Motorized Pulley consists of the Motorized Pulley and two fixing brackets! Exposed drives can require up to eight or more separate components, most of which have to be purchased from different suppliers or custom manufactured.

Low noise

Thanks to the totally sealed enclosure and high quality gears the Rulmeca Motorized Pulley runs almost at a whisper – a very important fact in today's modern factory environments. However, for some special application, a lower noise level could be required.

The Rulmeca Motorized Pulley – the ideal drive unit for conveyors **“Fit it and forget it”**



Excavator in a US cement application. Two Motorized Pulleys type 800H drive both the incoming & outgoing conveyors.



Compact and reliable drive unit using Motorized Pulley type 800H, 75kW at 3.15 m/sec.



Both Motorized Pulleys are fitted with brake shaft for connection to external brakes.

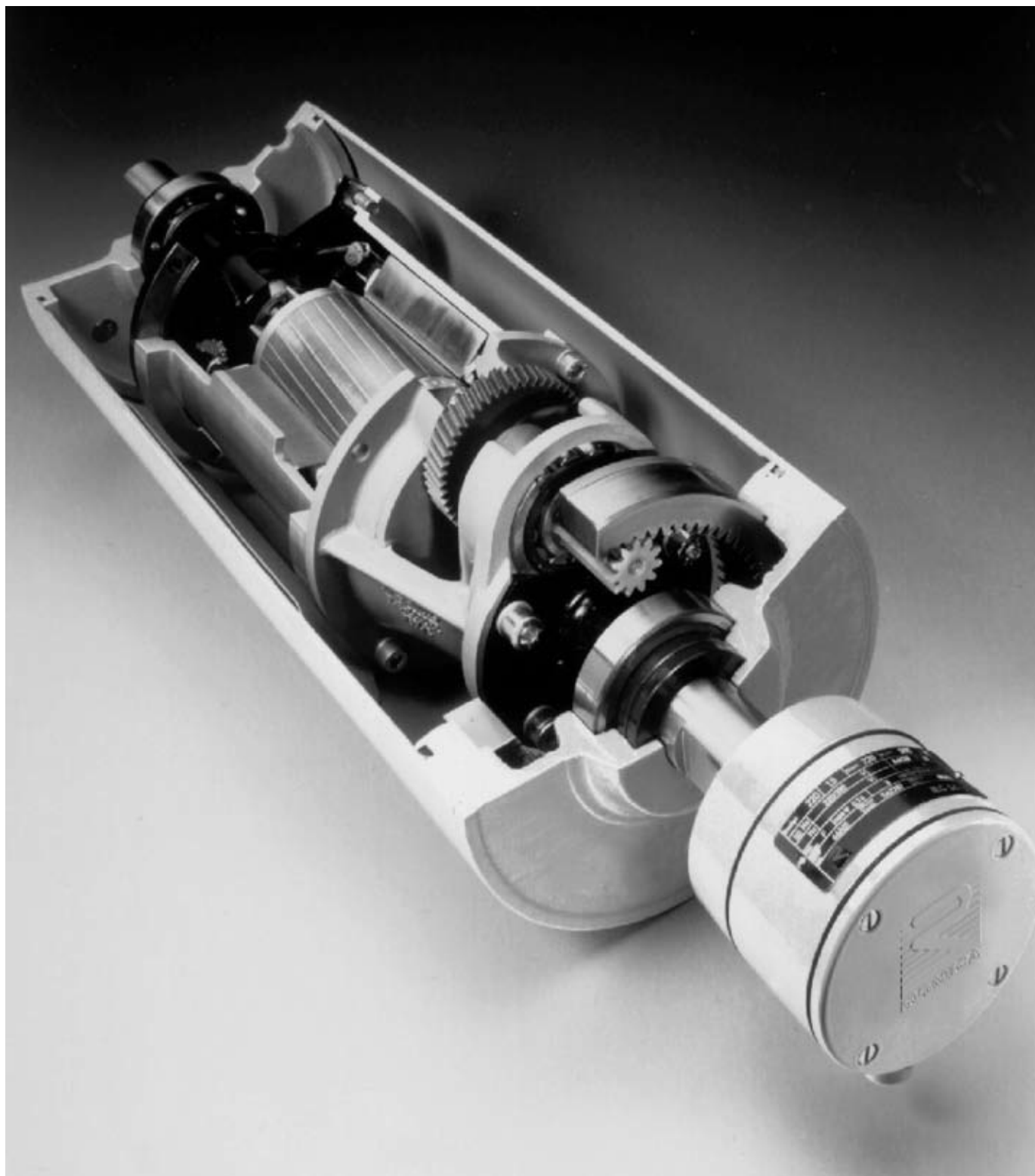

Sectioned model of Motorized Pulley type 220M.



INFORMATION NEEDED WHEN ORDERING Motorized Pulleys

CLIENT..... Name.....

Address

Phone..... Fax..... E-mail..... Date.....

What is the application?

(Describe type of application, material and ambient condition)

- Abrasive Corrosive Wet Wash down Humid Dry Dusty Other

Motorized Pulleys:

Quantity?.....(Pieces) Power?..... kW HP Dual drive

Diameter of shell?.....(mm without lagging) Shell width (RL).....(mm)

Belt speed?.....(m/sec.) Frequency? 50Hz 60Hz

Voltage..... (V) No. of phases? 3 phase Single phase

- Matching standard terminal box? Stainless steel terminal box?
 Cable solution? Straight connector? Elbow connector? Screened cable?
 Cable length? 1m (Standard) 3 m
 Electromagnetic brake? External brake shaft?
 Mechanical backstop? Clockwise rotation (Standard) Anti-clockwise rotation
 Mounting brackets? Type?..... Quantity?.....(Pieces)
 Lagging? Rubber? Black? White? Smooth? Diamond? Hot vulcanised?
 Ceramic type? Oil; Fat & Grease Thickness?.....(mm)

Motorized Pulleys Options:

- 2-speed motors? CSAus approved motors?
 Insulation Class? Class F (Standard) Class H
 Special oil? Synthetic Food grade
 Vertical or non-horizontal installation Vertical NON-horizontal between 5° - ≤90°
 TOTAL stainless steel with re-greasable seals TS7N TS9N
 TOTAL stainless steel without re-greasable seals TS10N
 Semi-rust-free TS11 TS12
 Re-greasable labyrinth seals – mild steel Anticondensation heater
 Non-regreasable labyrinth seals Dust explosion proof – ATEX 95 – Zone 22 Parallel shell (cylindrical)

Idler Pulleys:

- Idler Pulley? TS7N TS9N TS10N Qty.:..... Diameter of Pulley?.....(mm) Type:.....
 Idler Pulley? TS11(N) TS12(N) Qty.:..... Diameter of Pulley?.....(mm) Type:.....
 Mounting brackets? Type:..... Qty.:.....

NOTES, special options, parallel shell, lagging, re-greasable labyrinth seals etc.....

To be filled in by Rulmecca:

SUGGESTED Motorized Pulley:..... EDP No..... Qty.:.....
Options:..... Mounting brackets:..... Qty.:.....
Idler Pulley/EDP no.:..... Qty.:..... Mounting brackets:..... Qty.:.....
Accessories, types, options and comments.....



Motorized Pulley 138E, Ø 138 mm

Motorized Pulley 138E, with machined helical gear box, performs an efficiency, in a compact diameter of 138 mm only. With a min RL of 300 mm and powers ranging from 0.10 to 0.75kW this size of motorized pulley is suitable for most duties requiring such a small diameter - e.g.:

- Light agriculture and bulk solids handling conveyors
- Mobile or portable conveyors
- As a drive unit for brush cleaners etc.

Motorized pulley 138E has standard IP66/67 enclosure and is available in complete stainless steel execution for wash down application.

For the choice of the Motorized Pulley it is very important to know or to calculate the belt tension T1+T2 (radial load). This **MUST NOT OVERCOME** the "max. radial load" allowed as shown in the catalogue. Be careful to very high belt tensions when using thick, heavy and/or large belts.

If the type 138E cannot provide the necessary max. radial load T1+T2, you have to choose a Motorized Pulley with a bigger diameter.

STANDARD SPECIFICATION of motorized pulley

- Crowned mild steel shell, outside diameter 138mm.
- Mild steel shafts.
- Shell and shafts treated with anti-rust wax.
- Die cast aluminium bearing houses.
- Gearbox from die cast aluminium 2- and 3-stages.
- Sealing system-degree of protection IP66/67 (EN60034-5).
- Die cast aluminium terminal box with WAGO clamp.
Voltage: most common globally used voltages available. Please specify!
- 3-phase induction motor with one rated voltage – either low or high voltage
- Available in both 50Hz or 60Hz.
- Star connection (Delta connection on request).
- Motor windings with insulation class F (insulation class H on request).
- Dynamical balanced rotor.
- Two oil plugs (one with magnet).
- Minimum roller length (RL) 300mm (0.75kW: min RL 320mm).
- Max. RL 1800mm (from RL800 with reinforced shaft, from RL1000 plus reinforced shell).
- Standard mineral oil ISOVG150 (synthetic oil ISOVG220 on request).
- Oil change recommended every 20.000 operational hours.
- Single phase AC motors available in 0.20, 0.37 and 0.55kW, supplied with all necessary run and start capacitors (if needed) together with current depending relay.
- Without start capacitor the starting torque is 70% of the nominal torque only
- Horizontal installation (angled and vertical installation on request)

STAINLESS STEEL

execution TS 9

- Crowned stainless steel shell (AISI304), outside diameter 138 mm.
- Stainless steel shafts (AISI303/304).
- Stainless steel solid end housing enclosed (AISI304/316)
- Re-greasable labyrinth seals (AISI304).
- FDA & USDA food grade grease
- Option: FDA & USDA food grade recognized oil.
- Fully stainless steel (AISI304) terminal box.
- Fully stainless steel (AISI304) straight connector.
- Two stainless steel oil plugs (one with magnet).

TS10

- As TS9 but without re-greasable labyrinth seals

TS11

- As TS9 but with mild steel shell,

TS12

- As TS10 but with mild steel shell,

When ordering, please specify the required voltage, electrical connection and eventual TS-number, options, brackets and idler pulleys.

- Environmental consideration: page 77
- Technical precautions: page 81-92,
- Optional extras: page 9 and back cover,
- Connection diagram: page 98-99,



OPTIONAL EXTRAS

Motorized Pulley 138E

Specifications

138E

Total stainless steel option AISI 304 range	Re-greasable labyrinth seals!	x
Food grade oil & grease - FDA & USDA recognized - available on request		x
Dust explosion proof Motorized Pulleys - ATEX 95 - Zone 22 - for applications handling of dusty grain etc. According to European Directive 94/9/EC.		On request!
TOTAL acid resistant stainless steel option - AISI 316		x
Black rubber lagging - STANDARD specifications: - Smooth lagging - Hardness 60 ±5 Shore A - Diamond lagging - Hardness 60 ±5 Shore A		o
White smooth rubber lagging (FDA). Oil, fat & grease resistant		o
SPECIAL lagging available on request - e.g. hot vulcanized etc.		o
Single phase motors available on request		x
Electromagnetic brake		x
Min. RL dimensions by (mm)		50
Mechanical backstop		x
Modified for vertical mounting		o
Modified for mounting between 5° - ≤90° - e.g. for magnetic separators		o
Insulation class F - Allowable ambient temperature: -25°C/+40°C		Std.
Insulation class H with synthetic oil - Allowable ambient temperature: -25°C/+40°C		x
Low noise drives for noise sensitive areas		x
Parallel shell		x
Thermal protector		Std.
IP66/67 Compact stainless steel - AISI 304 or 316 range - terminal box		x
Straight or elbow connector with flying lead		x
Straight connector with flying lead - Stainless steel - AISI 304 range		x
Shaft sealing system - degree of protection IP66/67 (EN60034-5)		Std.
Screened cables - a MUST together with Frequency Converters		x
Euro wide range voltage (3x220-240V / 380-415V 50 Hz) with +/-10% tolerance - DIN IEC 38 or (3x380-400V / 660-690V 50 Hz)		Std.
Special voltages - 50 and/or 60 Hz Please specify!		x
CSA approved motors - available on request only!		x

X = Optional extras

o = Available as option with certain limitations. Please refer to Technical precautions pages 81-92!

Std. = Fitted as standard

Motorized Pulley 138E, Ø 138 mm

Motorized Pulley with Terminal box

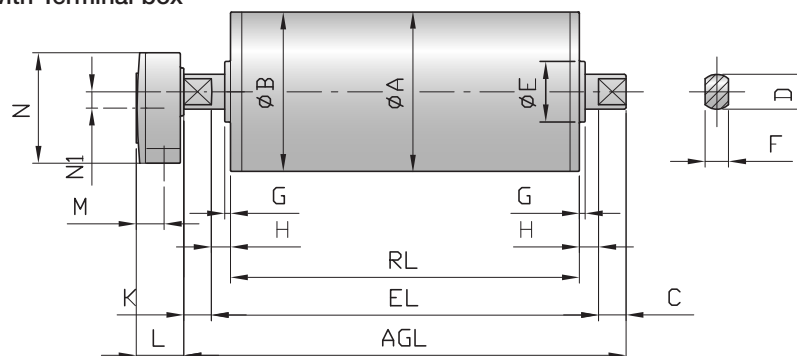

Motorized Pulley with cable Straight connector

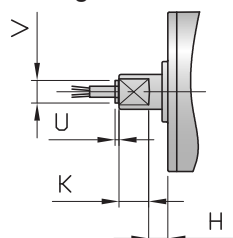

Elbow connector

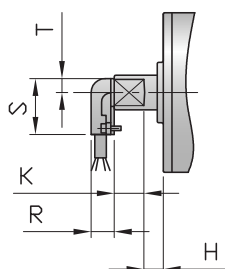

Front shaft with cable slot

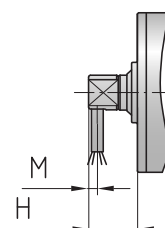

Idler pulley stainless steel version; cylindric option

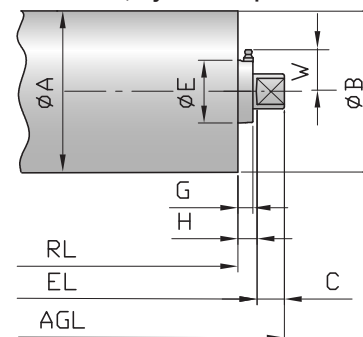

Standard measurements

Type / Option	Ref.	A mm	B mm	C mm	D mm	E mm	F mm	G mm	H mm	K mm	W mm	L mm	M mm	N mm	N1 mm	U mm	V mm	R mm	S mm	T mm	
138E (UT138E) / Terminal box		138.5	137	23.5	30	54	20	5	16.5	23.5	36	41	24	95	14						
SS version (regreasable seals)					64.5		13.5						36		3.5	19.5					
Straight connector									16.5	25.5		3.5				3.5	19.5				
Elbow connector									16.5	25.5		20						20	48	12	
Front shaft with cable slot										25.5			8-11								

Mounting brackets KL30

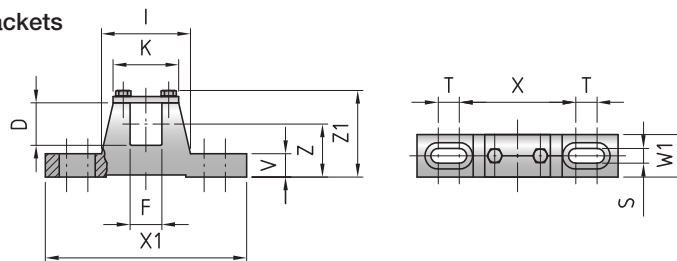

Motorized Pulley	Material	Dimensions											Weight kg	
		D mm	F mm	I mm	K mm	S mm	T mm	V mm	W1 mm	X mm	X1 mm	Z mm		Z1 mm
138E	Cast iron	30	20	86	57	11	17	12	24	110	180	44.5	72	0.7



Motorized pulley 138E – Ø 138 mm

50 Hz

Motor			Nominal belt speed at Full Load 50Hz m/sec	Torque Nm	Belt Pull N	Max. Radial Load T1+T2 N	Weight in kg for STANDARD width																	Type of Bracket
Power kW/HP	No. of Poles	Gear stages					Dimension RL in mm																	
							300	320	350	400	450	500	550	600	650	700	750	800	850	900	950	1000	per 50 mm up to 1800	
0.10/0.13	12	3	0.04	159	2295	4740	14	14.5	15	16	17	18	19	20	21.5	23	24	25	26	27	28	29	Available on request	KL30
			0.05	138	1990																			
			0.06	111	1600																			
0.18/0.25	8	3	0.08	163	2350	4740	14	14.5	15	16	17	18	19	20	21.5	23	24	25	26	27	28	29		
			0.10	131	1890																			
			0.13	108	1555																			
0.24/0.33	6	3	0.16	73	1050	4740	14	14.5	15	16	17	18	19	20	21.5	23	24	25	26	27	28	29		
			0.20	62	890																			
			0.25	62	890																			
0.37/0.50	6	3	0.32	50	720	4740	14	14.5	15	16	17	18	19	20	21.5	23	24	25	26	27	28	29		
			0.10	163	2255																			
			0.13	131	1735																			
0.37/0.50	4	3	0.16	153	2205	4740	14	14.5	15	16	17	18	19	20	21.5	23	24	25	26	27	28	29		
			0.20	126	1815																			
			0.25	104	1500																			
0.55/0.75	2	3	0.32	70	1010	4250	14	14.5	15	16	17	18	19	20	21.5	23	24	25	26	27	28	29		
			0.40	60	865																			
			0.50	48	690																			
0.75/1.00	4	2	0.63	40	575	4740	14	14.5	15	16	17	18	19	20	21.5	23	24	25	26	27	28	29		
			0.80	30	430																			
			1.00	40	575																			
0.75/1.00	2	2	1.25	33	475	4250	14	14.5	15	16	17	18	19	20	21.5	23	24	25	26	27	28	29		
			1.60	24	345																			
			0.32	159	2295																			
0.75/1.00	4	2	0.40	127	1830	4740	14	14.5	15	16	17	18	19	20	21.5	23	24	25	26	27	28	29		
			0.50	102	1470																			
			0.63	84	1210																			
0.75/1.00	2	2	0.80	67	965	4250	14	14.5	15	16	17	18	19	20	21.5	23	24	25	26	27	28	29		
			1.00	54	775																			
			1.25	44	635																			
0.75/1.00	2	2	1.60	33	1312	4250	14	14.5	15	16	17	18	19	20	21.5	23	24	25	26	27	28	29		
			0.80	67	965																			
			1.00	54	775																			

Motor	Max. Radial Load T1+T2 N	Weight in kg for STANDARD width																	Type of Bracket
		Dimension RL in mm																	
		300	320	350	400	450	500	550	600	650	700	750	800	850	900	950	1000	per 50 mm up to 1800	
Idler Pulley UT138E	4740	6.5	7	7.5	8.5	9.5	10.5	11.5	12.5	13.5	14.5	15.5	16.5	18.5	19.5	20	21.5	Available on request	KL30



Motorized Pulley 138E

Spare Parts List and sectional drawings

Pos.	Description	Pos.	Description	Pos.	Description
1	Front shaft	31	Labyrinth seal cover	110	Screw
3	Rear flange	53	Nipple (terminal box)	111	Screw
5	Bearing housing complete with geared rim	53.1	Cable seal nipple (cable option)	113	Screw
7	Bearing housing complete	55	Spacer bushing	114	Socket set screw
8	Gearbox	56	Spacer bushing	115	Oil plug with magnet
10	Terminal box – bottom part	63	Ball bearing	126	Key
11	Terminal box cover	64	Needle bearing	127	Key
12	Shell	65-70	Ball bearing	131	Key
16	Rear shaft	71	Inner race	132	Key
19	Input wheel	74	Locking ring	136	O-ring/Rubber seal
20	Output pinion	84	Locking ring	138	Rubber seal
22	Geared rim	86	Locking ring	139	Grease nipple
23	Intermediate pinion shaft	93	Elbow or straight connector	140	Deflection seal
24	Intermediate wheel	102	Screw	142	Double lip s
		103	Screw	143	O-ring

2-stage gearbox

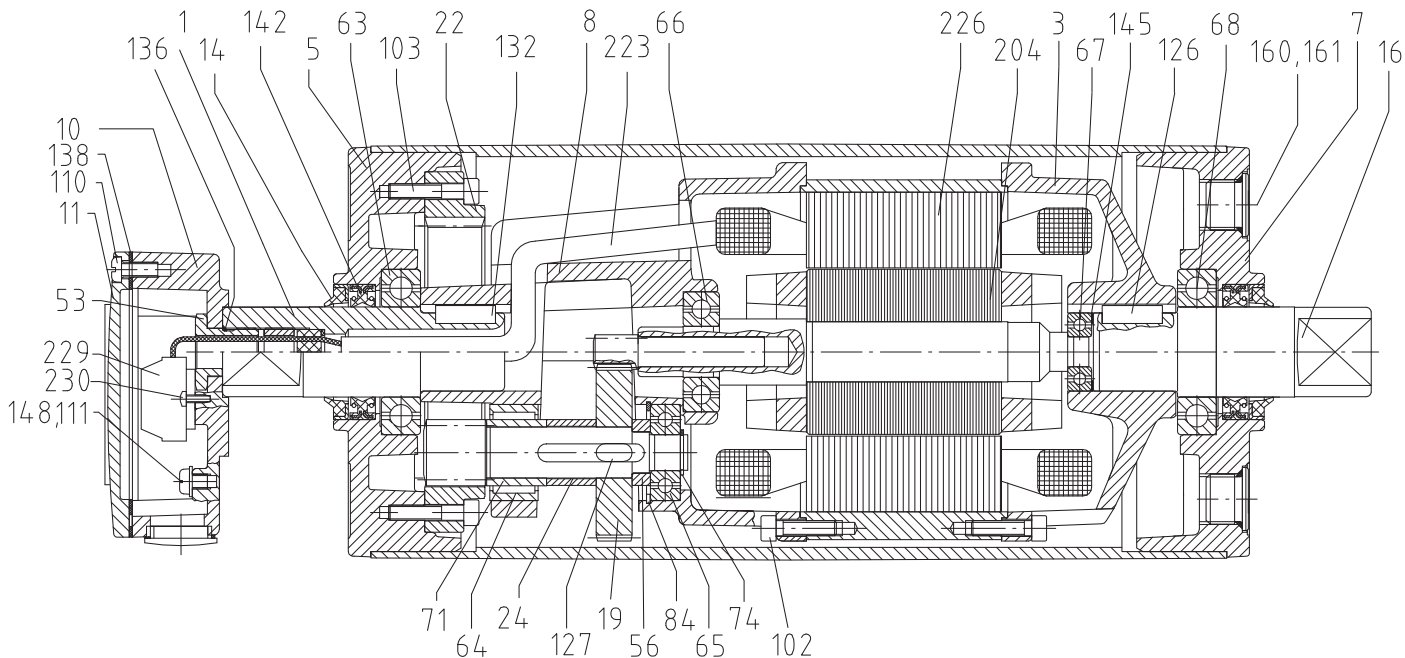

Motorized Pulley 138E

Spare Parts List and sectional drawings

Pos.	Description	Pos.	Description	Pos.	Description
145	Distance washer	161	O-ring	210	Fixing guard
146	Washer	163	O-ring	223	Cable
148	Washer	167	Screw	226	Stator complete
150	Electromagnetic brake	200	Rubber seal	229	WAGO clamp terminals
150.1	Friction disc	204	Rotor complete with pinion	230	Fixing bolts
156	Rectifier (not shown)	208	Bearing housing with labyrinth groove	240	Distance ring
160	Oil plug				

SS oil plug

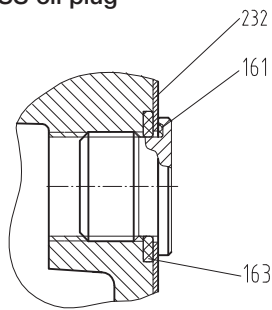

Cable version with elbow connector

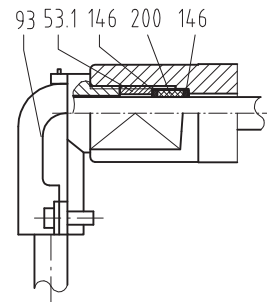

Labyrinth option

Cable version with straight connector

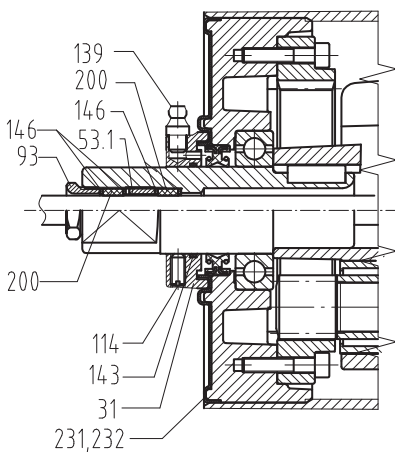

3-stage gearbox

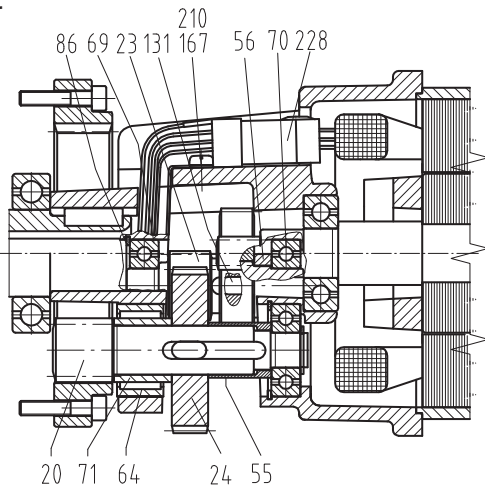

Electromagnetic brake

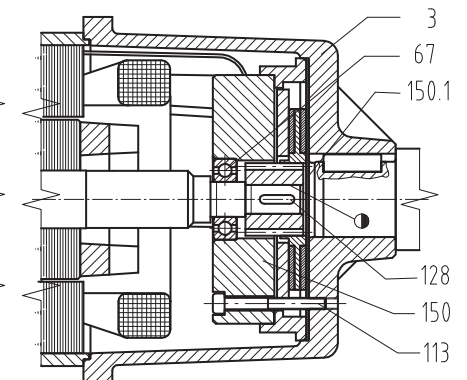



Motorized Pulley 165E, Ø 165 mm

Motorized Pulley 165E, with machined helical gear box, performs an efficiency, in a compact diameter of 165 mm only. With a min RL of 400 mm and powers ranging from 0.11kW to 1.5kW this size of motorized pulley is suitable for most duties requiring such a small diameter – e.g.:

- Light agriculture and bulk solids handling conveyors
- Mobile or portable conveyors
- As a drive unit for brush cleaners etc.

Motorized pulley 165E has standard IP66/67 enclosure and is available in complete stainless steel execution for wash down application.

For the choice of the Motorized Pulley it is very important to know or to calculate the belt tension T1+T2 (radial load). This **MUST NOT OVERCOME** the "max. radial load" allowed as shown in the catalogue. Be careful to very high belt tensions when using thick, heavy and/or large belts.

If the type 165E cannot provide the necessary max. radial load T1+T2, you have to choose a Motorized Pulley with a bigger diameter.

STANDARD SPECIFICATION of motorized pulley

- Crowned mild steel shell, outside diameter 165mm.
- Mild steel shafts.
- Shell and shafts treated with anti-rust wax.
- Die cast aluminium bearing houses.
- Gearbox from die cast aluminium 2- and 3-stages.
- Sealing system-degree of protection IP66/67 (EN60034-5).
- Die cast aluminium terminal box with WAGO clamp.
Voltage: most common globally used voltages available. Please specify!
- 3-phase induction motor with one rated voltage – either low or high voltage
- Available in both 50Hz or 60Hz.
- Star connection (Delta connection on request).
- Motor windings with insulation class F (insulation class H on request).
- Dynamical balanced rotor.
- Two oil plugs (one with magnet).
- Minimum roller length (RL) 400mm (0.37kW: min RL 350mm).
- Max. RL 1800mm (longer RL on request).
- Standard mineral oil ISOVG150 (synthetic oil ISOVG220 on request).
- Oil change recommended every 20.000 operational hours.
- Single phase AC motors available in 0.37kW and 1.10kW, supplied with all necessary run and start capacitors (if needed) together with current depending relay.
- Without start capacitor the starting torque is 70% of the nominal torque only
- For horizontal installation (angled and vertical installation on request)

STAINLESS SREEL

execution TS 9

- Crowned stainless steel shell (AISI304), outside diameter 165 mm.
- Stainless steel shafts (AISI303/304).
- Stainless steel solid end housing enclosed (AISI304/316)
- Re-greasable labyrinth seals (AISI304).
- FDA & USDA food grade grease
- Option: FDA & USDA food grade recognized oil.
- Fully stainless steel (AISI304) terminal box.
- Fully stainless steel (AISI304) straight connector.
- Two stainless steel oil plugs (one with magnet).

TS10

- As TS9 but without re-greasable labyrinth seals,

TS11

- As TS9 but with mild steel shell,

TS12

- As TS10 but with mild steel shell,

When ordering, please specify the required voltage, electrical connection and eventual TS-number, options, brackets and idler pulleys.

- Environmental consideration: page 77
- Technical precautions: page 81-92,
- Optional extras: page 15 and back cover,
- Connection diagram: page 98-99,



OPTIONAL EXTRAS

Motorized Pulley 165E

Specification

165E

Total stainless steel option AISI 304 range	Re-greasable labyrinth seals!	x
Food grade oil & grease - FDA & USDA recognized - available on request		x
Dust explosion proof Motorized Pulleys - ATEX 95 - Zone 22 - for applications handling of dusty grain etc. according to European Directive 94/9/EC.		On request!
Black rubber lagging - STANDARD specifications: - Smooth lagging - Hardness 60 ±5 Shore A - Diamond lagging - Hardness 60 ±5 Shore A		o
White smooth rubber lagging (FDA). Oil, fat & grease resistant		o
Single phase motors available on request		x
Electromagnetic brake (for 5.5 kW not available)		x
	Min. RL dimensions by (mm)	50
Mechanical backstop		x
Modified for vertical mounting		o
Modified for mounting between 5° - ≤90° - e.g. for magnetic separators		o
Insulation class F - Allowable ambient temperature: -25°C/+40°C		Std.
Insulation class H with synthetic oil - Allowable ambient temperature: -25°C/+40°C		x
SPECIAL motors for applications with NO belt contact		o
Low noise drives for noise sensitive areas		x
Parallel shell		x
Thermal protector		Std.
IP66/67 Compact stainless steel - AISI 304 or 316 range - terminal box		x
Straight or elbow connector with flying lead		x
Straight connector with flying lead - Stainless steel - AISI 304 range -		x
Shaft sealing system - degree of protection IP66/67 (EN60034-5)		Std.
Screened cables - a MUST together with Frequency Converters		x
Euro wide range voltage (3x220-240V / 380-415V 50 Hz) with +/-10% tolerance - DIN IEC 38 or (3x380-400V / 660-690V 50 Hz)		Std.
Special voltages - 50 and/or 60 Hz	Please specify!	x
CSA approved motors - available on request only!		x

X = Optional extras

o = Available as option with certain limitations. Please refer to Technical precautions pages 81-92!

Std. = Fitted as standard

Motorized Pulley 165E, Ø 165 mm

Motorized pulley with Terminal box

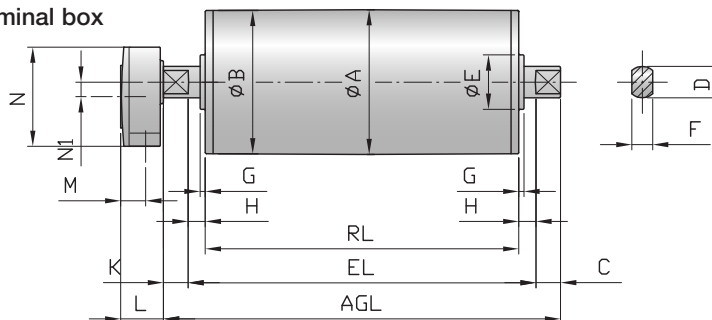

Straight connector

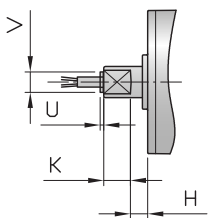

Elbow connector

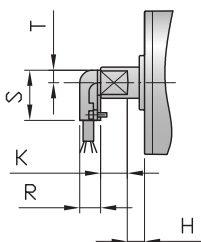

Front shaft with cable slot

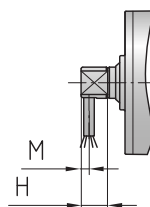

Idler pulley SS version

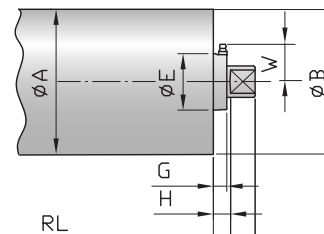

Standard measurements

Type / Option	Ref.	A mm	B mm	C mm	D mm	E mm	F mm	G mm	H mm	K mm	W mm	L mm	M mm	N mm	N1 mm	U mm	V mm	R mm	S mm	T mm	
165E (UT165E) / Terminal box		165	163.5	43.5	40	80	30	10	21.5	41.5	48	41	24	95	14						
SS version (regreasable seals)						64.5		13.5	21.5							4	27				
Straight connector									21.5	43.5						4	27				
Elbow connector									21.5	43.5								20	48	12	
Front shaft with cable slot										43.5			8-11								

Mounting brackets KL40

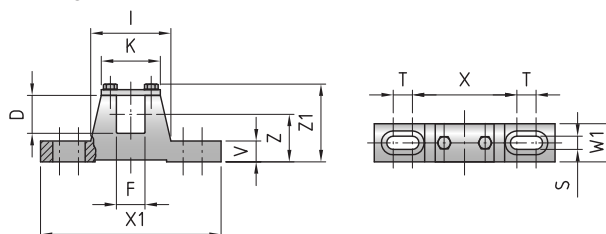

Motorized Pulley	Material	Dimensions												Weight kg
		D mm	F mm	I mm	K mm	S mm	T mm	V mm	W1 mm	X mm	X1 mm	Z mm	Z1 mm	
165E	Steel	40	30	84	62	14	20	22	40	110	190	50	83	2.1



Motorized pulley 165E – Ø 165 mm

50 Hz

Motor			Nominal belt speed at Full Load 50Hz m/sec	Torque Nm	Belt Pull N	Max. Radial Load T1+T2 N	Weight in kg for STANDARD width																			Type of Bracket
Power kW/HP	No. of Poles	Gear stages					Dimension RL in mm																			
							350	400	450	500	550	600	650	700	750	800	850	900	950	1000	1050	1100	per 50 mm up to 1800			
0.11/0.15	12	3	0.05	170	2070	9330																				
			0.06	141	1700																					
			0.08	113	1375																					
			0.10	86	1045																					
0.37/0.50	6	3	0.13	239	2905	9330																				
			0.16	193	2345																					
	4	3	0.20	157	1910	9330																				
			0.25	127	1545																					
			0.32	97	1175																					
		0.40	77	930																						
		2	0.50	60	735																					
			0.63	49	595																					
0.80	38		455																							
1.00	29	360																								
0.75/1.00	6	3	0.16	341	4140	9330																				
			0.20	302	3665																					
	4	3	0.25	248	3005	9330																				
			0.32	189	2295																					
			0.40	162	1815																					
		2	0.50	119	1435																					
			0.63	96	1160																					
			0.80	72	885																					
1.00	57	700																								
1.10/1.50	4	3	0.25	332	4030	9330																				
			0.32	272	3305																					
	2	3	0.40	226	2745	9330																				
			0.50	183	2220																					
			0.63	139	1690																					
		0.80	110	1340																						
		2	1.00	87	1060																					
			1.25	70	855																					
	1.60		54	650																						
	2	2.00	42	515	6950																					
2.50		34	420																							
1.50/2.00	3	3	0.50	237	2880	9330																				
			0.63	195	2360																					
			0.80	154	1870																					
			1.00	122	1480																					
	2	2	1.25	98	1195	8700																				
			1.60	75	910																					
			2.00	59	720																					
			2.50	48	585																					
3.15	39	485																								

Available on request

KL40

Motor	Max. Radial Load T1+T2 N	Weight in kg for STANDARD width																			Type of Bracket
		Dimension RL in mm																			
		350	400	450	500	550	600	650	700	750	800	850	900	950	1000	1050	1100	per 50 mm up to 1800			
Idler Pulley UT165E	9330	12.5	14.0	15.5	17.0	18.5	20.0	21.5	23.0	24.5	26.0	27.5	29.0	30.5	32.0	33.5	35.0	Available on request	KL40		



Motorized Pulley 165E

Spare Parts List and sectional drawings

Pos.	Description	Pos.	Description	Pos.	Description
1	Front shaft	31	Labyrinth seal cover	102	Screw
3	Rear flange	53	Cable seal nipple (cable option)	103	Screw
5	Bearing housing complete with geared rim	53.1	Nipple (terminal box)	110	Screw
7	Bearing housing complete	55	Spacer bushing	111	Screw
8	Gearbox	56	Spacer bushing	112	Socket set screw
10	Terminal box – bottom part	63	Ball bearing	113	Screw
11	Terminal box cover	64	Needle bearing	114	Socket set screw
12	Shell	65-70	Ball bearing	115	Oil plug with magnet
16	Rear shaft	73	Locking ring	126	Key
19	Input wheel	74	Locking ring	127	Key
20	Output pinion	81	Locking ring	131	Key
22	Geared rim	84	Locking ring	132	Key
23	Intermediate pinion shaft	85	Locking ring	136	O-ring/Rubber seal
24	Intermediate wheel	86	Locking ring	138	Rubber seal
		93	Elbow or straight connector	139	Grease nipple

2-stage gearbox

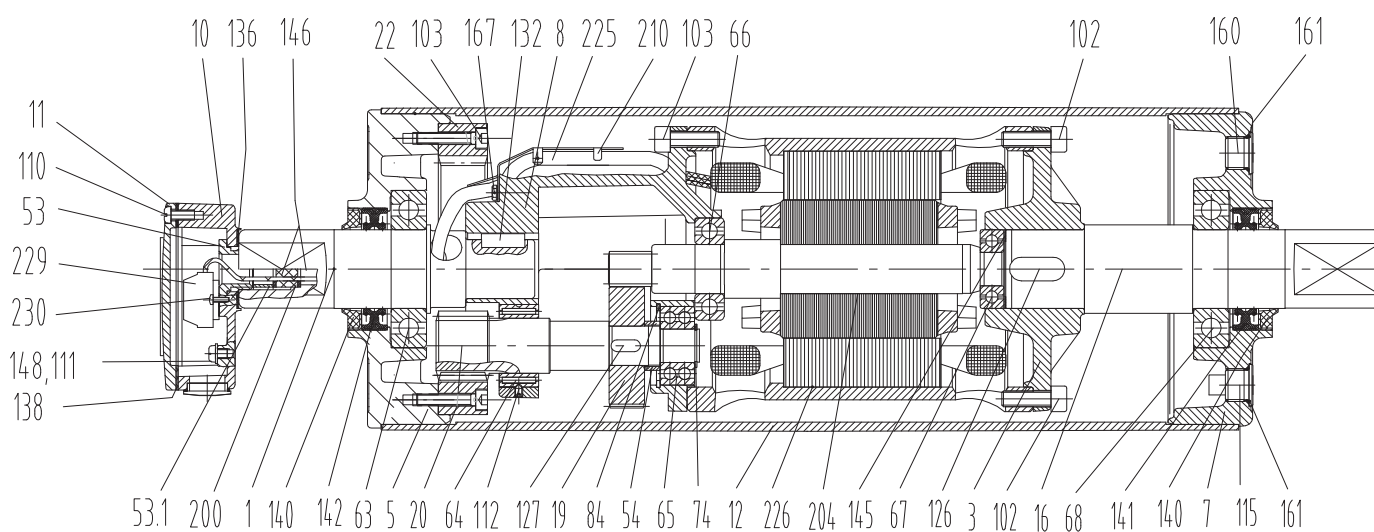

Motorized Pulley 165E

Spare Parts List and sectional drawings

Pos.	Description	Pos.	Description	Pos.	Description
140	Deflection seal	150.1	Friction disc	206	Insulated sleeve for wire protection
141	Double lip seal	156	Rectifier (not shown)	208	Bearing housing with labyrinth groove
142	Double lip seal	160	Oil plug	210	Fixing guard
143	O-ring	161	O-ring	225	Cable
145	Distance washer	163	O-ring	226	Stator complete
146	Washer	167	Screw	229	WAGO clamp terminals
148	Washer	200	Rubber seal	230	Fixing bolts
150	Electromagnetic brake	204	Rotor complete with pinion	240	Distance ring

SS oil plug

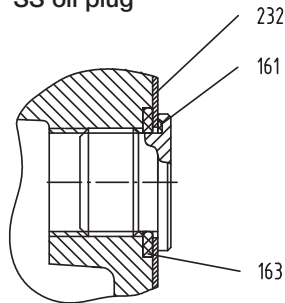

Cable version with elbow connector

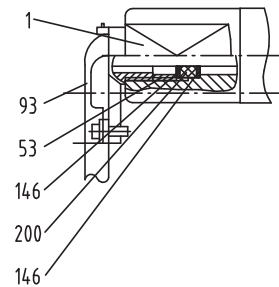

Stainless steel labyrinth option
Cable option with straight connector

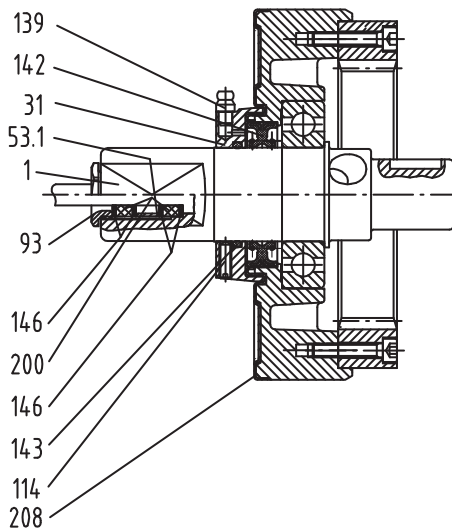

3-stage gearbox

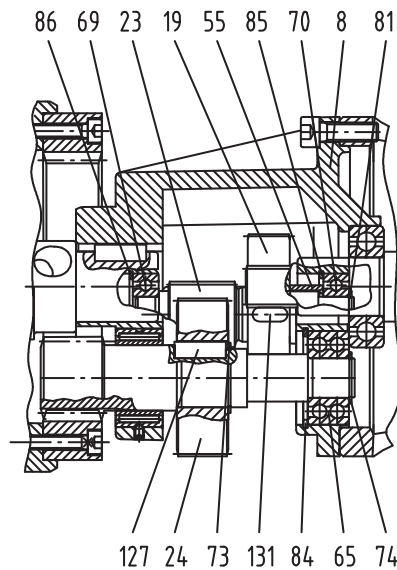

Electromagnetic brake

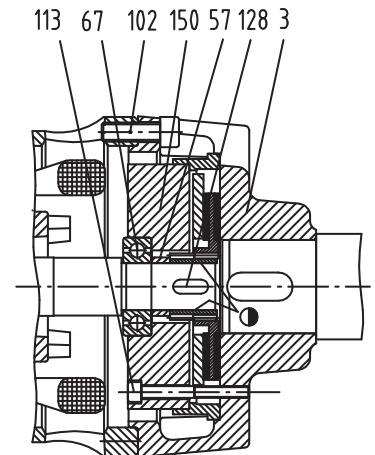



Motorized Pulley 220M & 220H, Ø 216 mm

To match your requirements in diameter 216 mm, our product range offers two different loading performances for your **BULK** applications:

- **M** for Medium-duty
- **H** for Heavy-duty

You have a choice. Therefore, it is important to notice the differences to choose the right type of pulley for the right application based on estimated belt tension (radial load) = $T1+T2$. The actual radial load **MUST** be **LESS** than the max. allowable radial load shown in this catalogue.

Be aware of increased belt tensions using **multi-ply thick heavy belts** and/or larger belt widths. If you do not find the belt tension needed in this diameter, you might have to choose a larger one.

M for Medium-duty

The internal parts of 220M are designed to match irregular working conditions in applications such as mobile crushing & screening, cement & concrete plants, mobile conveyors and open stone & gravel pits. 220M provide sufficient belt tension.

H for Heavy-duty

A reinforced 3-stage-gearbox provides 220H with the necessary strength needed for low speeds, high torque and the listed belt tension. 220H is popular in re-cycling (hand sorter conveyors), bunker discharge conveyors and where a combination of slow speed and high torque is required.

For the choice of the Motorized Pulley it is very important to know or to calculate the belt tension $T1+T2$ (radial load). This **MUST NOT** OVERCOME the "max. radial load" allowed as shown in the catalogue. Be careful to very high belt tensions when using thick, heavy and/or large belts.

If this type cannot provide the necessary max. radial load $T1+T2$, you have to choose a Motorized Pulley with a bigger diameter.

STANDARD SPECIFICATION of Motorized Pulley

- Crowned mild steel Ø 216 mm steel shell treated with anti-rust wax
- Powder coated cast iron bearing housings
- Mild steel shafts treated with anti-rust wax
- Shaft sealing system - degree of protection IP66/67 (EN60034-5)
- Compact powder coated die cast aluminium terminal box
- Larger powder coated die cast aluminium terminal box ≥ 5.5 kW
- 3-phase induction motors with thermal protector
- Voltage: wide range 3-phase single voltage. Most common voltages available. Please specify!
- Motor winding insulation Class F
- Dynamically balanced rotor
- One out of two oil plugs fitted with a magnet to filter the oil
- Oil change recommended every 20.000 operational hours
- Minimum RL. Please refer to pages 23-24
- Maximum RL – Please inquire!
- Non standard RL's available
- To be used in horizontal positions ± 5 degree only!

Please note:

- Straight or elbow connector available
- Parallel shell available. Diameter equal to dimension Ø A
- Two speed motors on request
- Special speed available on request
- Motorized Pulleys for non-horizontal positions available on request
- The high speed of 2-pole motors can cause higher noise levels and are therefore not recommended in noise sensitive areas

STAINLESS STEEL options

TS9N

- Stainless steel shell – AISI 304 range
- Stainless steel shafts – AISI 303/4 range
- Stainless steel covered bearing housings – AISI 316 range
- Stainless steel oil plugs – AISI 304 range – one out of two with magnet
- Stainless steel exterior bolts – AISI 304 range
- Re-greasable labyrinth seals with grease nipples in stainless steel – AISI 304 range
- Shaft sealing system – degree of protection IP66/67 (EN60034-5).

TS10N

- As TS9N, but WITHOUT re-greasable labyrinth seals.

SEMI-RUST-FREE options

TS11N

- As TS9N, but with crowned mild steel Ø 216 mm steel shell treated with anti-rust wax.

TS12N

- As TS10N, but with crowned mild steel Ø 216 mm steel shell treated with anti-rust wax.

Other Options:

- FDA & USDA food grade recognized oil and grease are NOT included in TS9N to TS12N, but available on request
- Complete Motorized Pulleys in acid resistant stainless steel – AISI 316 range – on request.

Electrical connection options:

- Salt water resistant powder coated aluminium terminal box with zinc plated exterior bolts
- Stainless steel terminal box – AISI 304 range (max. 4 kW)
- Straight stainless steel connector with flying lead – AISI 304 range (max. 4 kW).

When ordering, please specify the required voltage, electrical connection and eventual TS-number, options, brackets and idler pulleys.

- Environmental considerations: page 77-78
- Technical precautions: pages 81-92
- Optional extras: page 21 and back cover
- Connection Diagrams: pages 98-100.



OPTIONAL EXTRAS

Motorized Pulley 220M & 220H

Specification

220M & 220H

Total stainless steel option AISI 304 range	TS9N Re-greasable labyrinth seals!	x
Total stainless steel option AISI 304 range	TS10N Standard seals!	x
Semi-rust free option	TS11N Re-greasable labyrinth seals!	x
Semi-rust free option	TS12N Standard seals!	x
Food grade oil & grease - FDA & USDA recognized - available on request		x
Dust explosion proof Motorized Pulleys - ATEX 95 - Zone 22 - for applications handling of dusty grain etc. According to European Directive 94/9/EC.		On request!
TOTAL acid resistant stainless steel option - AISI 316		x
Re-greasable labyrinth seals - mild steel		x
Black rubber lagging - STANDARD specifications: - Smooth lagging - Hardness 60 ±5 Shore A - Diamond lagging - Hardness 60 ±5 Shore A		o 5 mm 6 mm
White smooth rubber lagging (FDA). Oil, fat & grease resistant		x
SPECIAL lagging available on request - e.g. hot vulcanized etc.		x
Single phase motors available on request		x
Electromagnetic brake (for 5.5 kW not available) Min. RL dimensions increases by (mm)		x 100
Mechanical backstop		x
Modified for vertical mounting		o
Modified for mounting between 5° - ≤90° - e.g. for magnetic separators		o
Insulation class F - Allowable ambient temperature: -25°C/+40°C		Std.
Insulation class H with synthetic oil		x
SPECIAL motors for applications with NO belt contact		x
Low noise drives for noise sensitive areas		x
Parallel shell		x
Thermal protector		Std.
IP66/67 Compact powder coated aluminium terminal box - food grade approved		Std. ≤4.0 kW
IP66/67 Compact stainless steel - AISI 304 or 316 range - terminal box		≤4.0 kW
IP66/67 Larger powder coated aluminium terminal box - food grade approved		Std. ≥5.5 kW
Straight or elbow connector with flying lead		≤4.0 kW
Straight connector with flying lead - Stainless steel - AISI 304 range -		≤4.0 kW
Shaft sealing system - degree of protection IP66/67 (EN60034-5)		Std.
Screened cables - a MUST together with Frequency Converters		x
3-phase single voltage (3 x 400V) or (3 x 690V) 50Hz +/-10% tolerance - DIN IEC 38		Std.
Euro wide range voltage (3x220-240V / 380-415V 50 Hz) with +/-10% tolerance - DIN IEC 38 or (3x380-400V / 660-690V 50 Hz)		x
Special voltages - 50 and/or 60 Hz Please specify!		x
Dual voltage - delta/star - connection possibility!		x
CSA approved motors - available on request only!		x

x = Optional extra's

o = An option with certain limitations. Please refer to Technical precautions pages 81-92!

Std. = Fitted as standard

Motorized Pulley 220M & 220H, Ø 216 mm

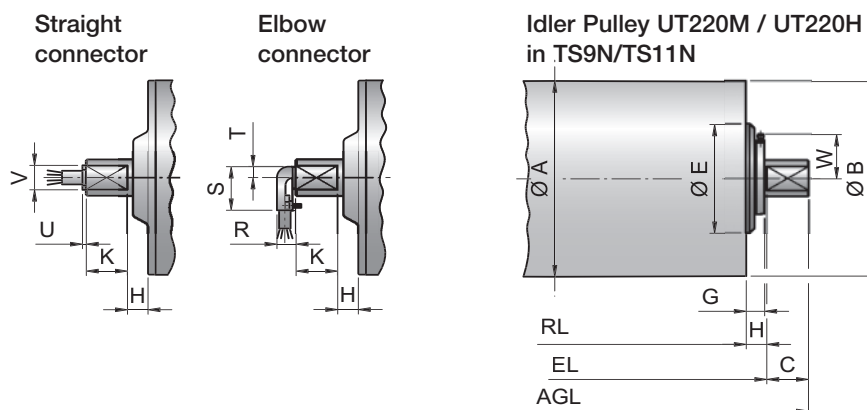
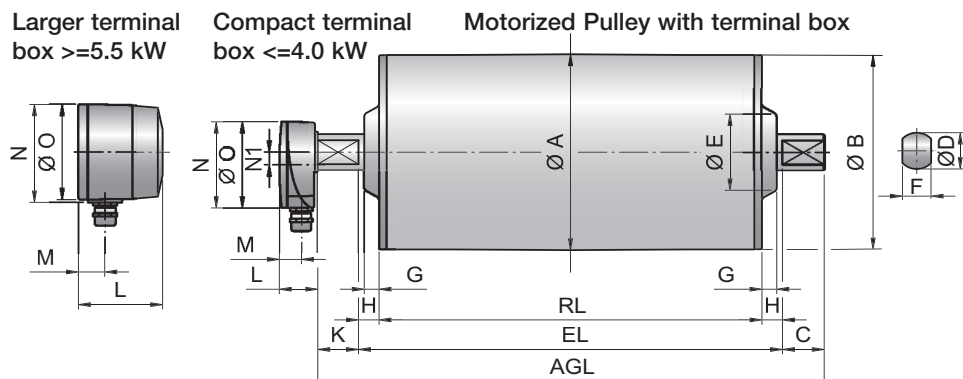

Type	Motorized Pulley or Idler Pulley (UT)											Compact terminal box <4.0 kW				Larger terminal box >5.5 kW				Straight connector <4.0 kW		Elbow connector <4.0 kW		
	A	B	C	D	E	F	G	TS9/11	H	K	W	L	M	N	N1	L	M	N	O	U	V	R	S	T
mm	mm	mm	mm	mm	mm	mm	mm	mm	mm	mm	mm	mm	mm	mm	mm	mm	mm	mm	mm	mm	mm	mm	mm	
220M & 220H	216	214.5	43.5	40	100	30	15.5	19.5	21.5	41.5	-	41	24	95	14	87	27	107	105	4	27	20	48	12
UT220M & UT220H	216	214.5	43.5	40	100	30	15.5	22.5	21.5	-	52	→ Idler Pulley shown in TS9N/TS11N version with re-greasable seals												

Mounting brackets KL41-HD

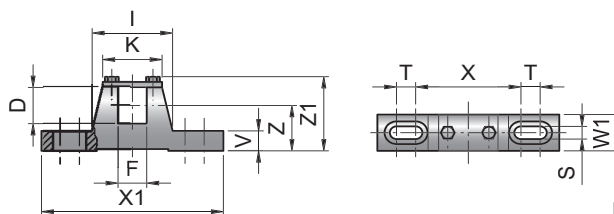

Type	Material	Bracket description	Dimensions												Weight kg
			D	F	I	K	S	T	V	W1	X	X1	Z	Z1	
mm	mm	mm	mm	mm	mm	mm	mm	mm	mm	mm	mm	mm	mm	mm	
220M & 220H	Steel	KL41-HD	40	30	84	62	14	20	22	40	110	190	50	83	2.1



Motorized Pulley 220M & 220H, Ø 216 mm

50 Hz

Power kW/HP	Motor		Nominal belt speed at Full Load 50Hz m/sec	Torque Nm	Belt Pull N	Max. Radial Load T1+T2 N	Special min. RL	Type	Weight in kg for STANDARD width										Type of Bracket	
	No. of Poles	Gear stages							Dimension RL in mm (RL >2000 mm available on request)											
									400	450	500	550	600	650	700	750	800	per 50 mm up to 2000		
0.37/ 0.50	8	3	0.13	291	2707	25000	450	220H		64	67	70	73	76	79	82	85	3 kg	KL41-HD	
			0.16	236	2195															
		2	0.20	190	1767	11500	400	220M	48	51	54	57	60	63	66	69	72	3 kg	KL41-HD	
			0.25	152	1414															
			0.32	118	1098															
			0.40	95	884															
			0.50	76	707															
0.63	60	558																		
0.80	47	437																		
1.00	38	353																		
1.25	30	279																		
0.55/ 0.75	8	3	0.13	432	4019	25000	500	220H			71	74	77	80	83	86	89	3 kg	KL41-HD	
			0.16	351	3265															
		2	0.20	282	2623	11500	450	220M	55	58	61	64	67	70	73	76	3 kg	KL41-HD		
			0.25	226	2102															
			0.32	176	1637															
			0.40	141	1312															
			0.50	113	1051															
0.63	89	828																		
0.80	70	651																		
1.00	56	521																		
1.25	45	419																		
0.75/ 1.00	8	3	0.13	592	5510	25000	500	220H			71	74	77	80	83	86	89	3 kg	KL41-HD	
			0.16	481	4476															
		2	0.20	385	3581	11500	450	220M	55	58	61	64	67	70	73	76	3 kg	KL41-HD		
			0.25	307	2856															
			0.32	239	2223															
			0.40	191	1777															
			0.50	153	1423															
0.63	122	1135																		
0.80	96	893																		
1.00	77	716																		
1.25	62	577																		
1.10/ 1.50	6	3	0.16	705	6558	25000	500	220H			68	71	74	77	80	83	86	3 kg	KL41-HD	
			0.20	564	5246															
	4	3	0.25	452	4205	450	450	220H			61	64	67	70	73	76	79	82	3 kg	KL41-HD
			0.32	353	3284															
	4	2	0.40	282	2623	11500	400	220M	46	49	52	55	58	61	64	67	70	3 kg	KL41-HD	
			0.50	226	2102															
			0.63	178	1656															
0.80			141	1312																
1.00			112	1042																
1.25	90	837																		
1.60	70	651																		
2.00	56	521																		
2.50	45	419																		

Idler Pulley	11500	400	UT220M	25	27	29	31	33	35	37	39	41	2 kg	KL41-HD
		25000	400	UT220H		29	31	33	35	37	39	41	43	2 kg



Motorized Pulley 220M & 220H, Ø 216 mm

50 Hz

Power kW/HP	Motor		Nominal belt speed at Full Load 50Hz m/sec	Torque Nm	Belt Pull N	Max. Radial Load T1+T2 N	Special min. RL	Type	Weight in kg for STANDARD width											Type of Bracket
	No. of Poles	Gear stages							Dimension RL in mm (RL >2000 mm available on request)											
									400	450	500	550	600	650	700	750	800	per 50 mm up to 2000		
1.50/ 2.00	4	3	0.25	616	5730	25000	450	220H		61	65	68	71	74	77	80	83	3 kg	KL41-HD	
			0.32	481	4476															
	2	2		0.40	385	3581	11500	400	220M	48	51	54	57	60	63	66	69	72	3 kg	KL41-HD
				0.50	307	2856														
				0.63	243	2260														
				0.80	191	1777														
				1.00	153	1423														
				1.25	123	1144														
1.60	96	893																		
2.00	77	716																		
2.50	62	572																		
2.20/ 3.00	4	3	0.32	705	6558	25000	500	220H			68	72	75	78	81	84	87	3 kg	KL41-HD	
			0.40	564	5246															
	2	2		0.50	451	4195	11500	450	220M	55	58	61	64	67	70	73	76	3 kg	KL41-HD	
				0.63	358	3330														
				0.80	282	2623														
				1.00	226	2102														
				1.25	180	1674														
				1.60	140	1302														
2.00	115	1070																		
2.50	90	837																		
3.00/ 4.00	4	3	0.50	616	5730	25000	550	220H				74	77	80	83	86	89	3 kg	KL41-HD	
			0.63	481	4476															
	2	2		0.80	385	3581	11500	500	220M	60	63	66	69	72	75	78	3 kg	KL41-HD		
				1.00	307	2856														
				1.25	245	2279														
				1.60	192	1786														
				2.00	154	1433														
				2.50	123	1144														
4.00/ 5.50	2	3	0.63	649	6037	25000	550	220H				74	77	80	83	86	89	3 kg	KL41-HD	
			0.80	511	4754															
	2	2		1.00	409	3805	11500	500	220M	60	63	66	69	72	75	78	3 kg	KL41-HD		
				1.25	327	3042														
1.60	255	2372																		
2.00	204	1898																		
2.50	163	1516																		
5.50/ 7.50	2	3	0.80	702	6530	25000	550	220H				74	77	80	83	86	89	3 kg	KL41-HD	
			1.00	562	5228															
			1.25	450	4186															
			1.60	351	3265															
			2.00	281	2614															
2.50	225	2093																		

Idler Pulley	11500	400	UT220M	25	27	29	31	33	35	37	39	41	2 kg	KL41-HD
		25000	400	UT220H		29	31	33	35	37	39	41	43	2 kg

Motorized Pulley 220M, Ø 216 mm

Spare parts list and sectional drawings

Pos.	Description	Pos.	Description	Pos.	Description
1	Shell	24	2 dust lip seals at each side	70	Toothed washer
2	End housing with geared rim	24	Double lip seal at each side for labyrinth option	78	Gasket
3	End housing	25	O-ring	79	Holding clip or plastic tie
8	Geared rim	26	Bearing	85.1	Intermediate flange for brake assembly
9	Rotor pinion	27	Bearing	91	Electromagnetic brake
10	Input wheel	28	Bearing	93	Retaining ring
11	Output pinion	29	Bearing (Backstop solution: One-way-bearing)	95	Straight connector
12	Gear box	30	Bearing	96	Elbow connector
13	Front shaft	31	Bearing	101	Key
14	Rear shaft	39	Hexagon socket screw	104	Distance washer
15	Stator complete	40	Hexagon socket screw	120	Labyrinth cover
15.1	Rotor	41	Hexagon socket screw	121	Set screw
16	Terminal box complete	52	Magnetic oil plug	122	O-ring
17	Nipple	53	Distance washer	123	Grease nipple
20	Cover	53.1	Compression nipple	124	Distance washer
20.1	Cover with labyrinth groove	59	Countersunk head screw	143	O-ring
23	Rear flange	66	Waved spring washer	146	Special shaped compression washer
23.1	rear flange for backstop	68	Key	200	Rubber seal
23.2	Rear flange for electromagnetic Brake				

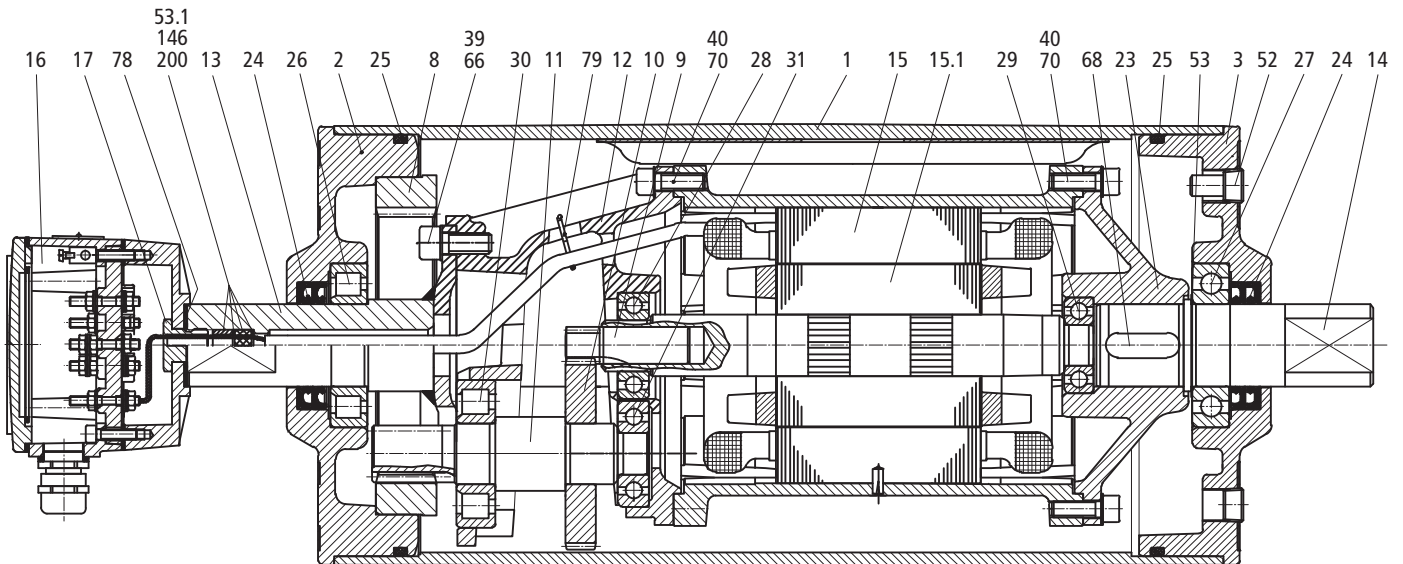



Motorized Pulley 220H, Ø 216 mm

Spare parts list and sectional drawings

Pos.	Description	Pos.	Description	Pos.	Description
1	Shell	20.1	Cover with labyrinth groove	95	Straight connector
2	End housing with geared rim	23	Rear flange	96	Elbow connector
3	End housing	23.1	Rear flange for backstop	101	Key
8	Geared rim	23.2	Rear flange for electromagnetic brake	104	Distance washer
9	Rotor pinion	24	2 Dust lip seals each side	120	Labyrinth cover
10	Input wheel	24	1 double lip seal at labyrinth option	121	Set screw
11	Output pinion	25	O-ring	122	O-ring
12	Gear box	26	Bearing	123	Grease nipple
13	Front shaft	27	Bearing	124	Distance washer
14	Rear shaft	28	Bearing	143	O-ring
15	Stator complete	29	Bearing (Backstop solution: One-way-bearing)	146	Special shaped compression washer
15.1	Rotor	30	Bearing	180	Intermediate pinion
16	Terminal box complete	40	Hexagon socket screw	181	Intermediate wheel
17	Nipple	41	Hexagon socket screw	182	Distance washer
20	Cover	52	Magnetic oil plug	183	Distance washer
		53	Distance washer	184	Roller bearing
		53.1	Compression nipple	185	Roller bearing
		59	Countersunk head screw	186	Key
		68	Key	187	Key
		70	Toothed washer	188	Retaining ring
		78	Gasket	190	Retaining ring
		79	Holding clip or plastic tie	191	Retaining ring
		85.1	Intermediate flange for brake assembly	194	Set crew
		91	Electromagnetic brake	196	Key
		93	Retaining ring	197	Spring-washer
				198	Distance washer
				200	Rubber seal
				202	Motor data plate

Intermediate Shaft

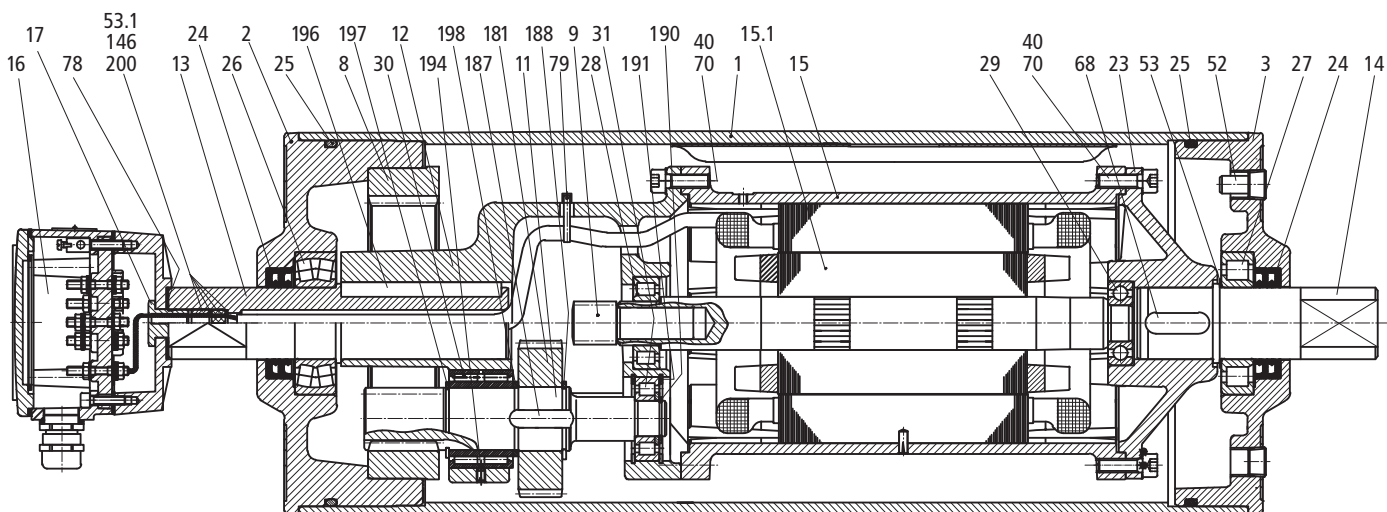
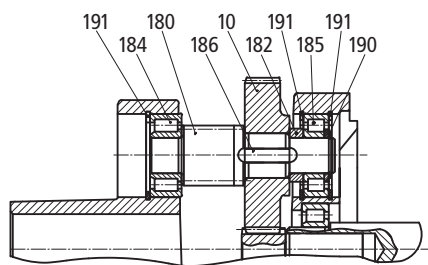

Motorized Pulley 220M & 220H, Ø 216 mm

Sectional drawings

Compact Terminal Box
with WAGO Clamping Block

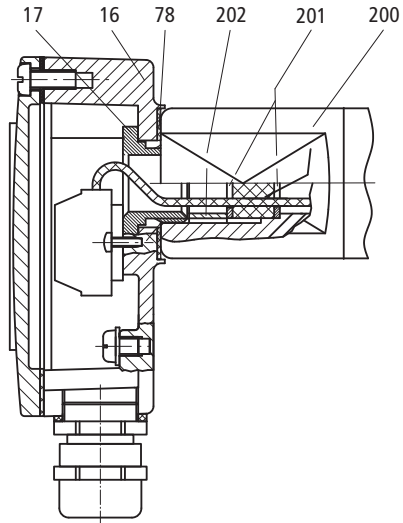

Straight Connector

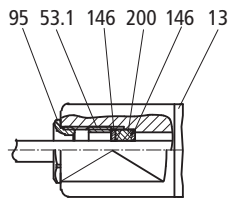

Electromagnetic Brake Option

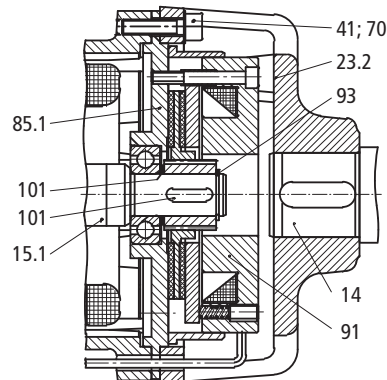

Backstop Option

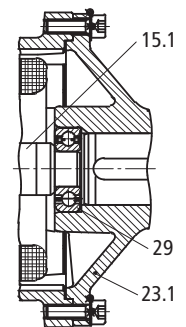

Elbow Connector

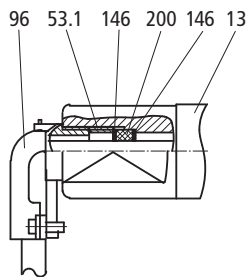

Short Version

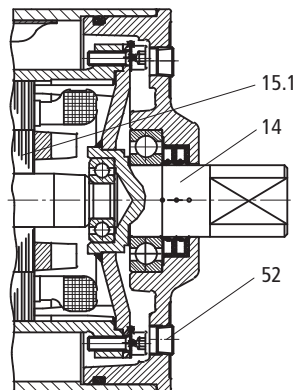

Labyrinth Option - Mild Steel

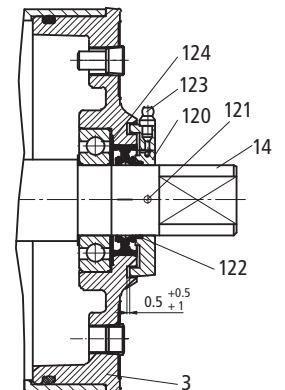



Motorized Pulley 220M & 220H, Ø 216 mm

Sectional drawings

220M & 220H
Stainless steel option TS10N & TS12N

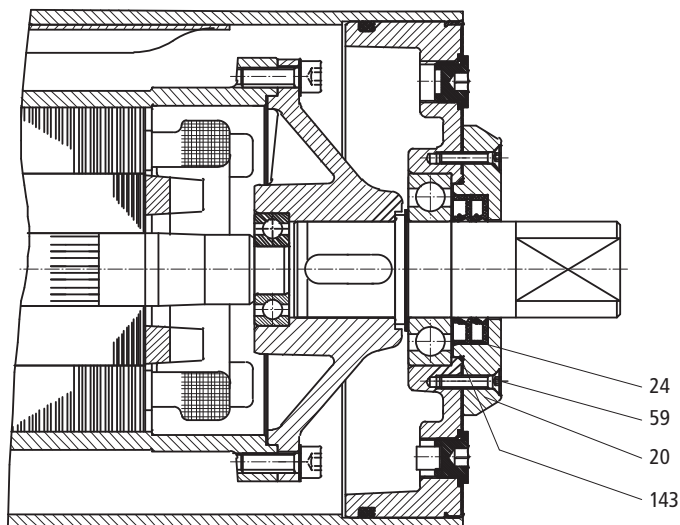

220M & 220H
Stainless steel option TS9N & TS11N

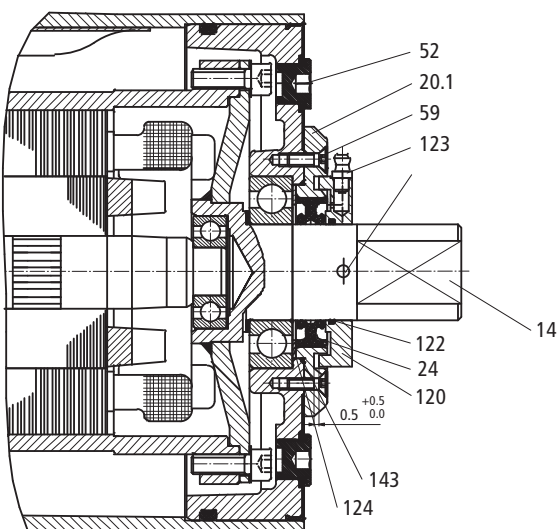



Mobile Crushing & Screening – Features: Compact, equal weight, distribution, reliable and NO maintenance.



Motorized Pulley 320L, 320M & 320H, Ø 320 mm

To match your requirements in diameter 320 mm, our product range offers three different loading performances for your BULK applications:

- L for Light-duty
- M for Medium-duty
- H for Heavy-duty

You have a choice.

Therefore, it is important to notice the differences to choose the right type of Pulley for the right application based on estimated belt tension (radial load) = T1+T2. The actual radial load **MUST** be **LESS** than the max. allowable radial load shown in this catalogue.

Be aware of increased belt tensions using multi-ply thick heavy belts and/or larger belt widths.

If you do not find the belt tension needed in this diameter, you might have to choose a larger one.

L for Light-duty

320L is meant for applications with regular and constant operating conditions. Max. allowable radial load has to be respected; therefore it is advisable to rubber lag these Pulleys to increase grip and to limit belt tension.

320L should NOT be used for e.g. feeder conveyors. (Motor/gearbox origin from 220M).

M for Medium-duty

The internal parts of 320M are designed for TOUGH and IRREGULAR working conditions - e.g. in crusher & screening applications, asphalt, cement and concrete plants etc.

H for Heavy-duty

Due to a solid 3-stage gearbox, Ø 50 mm shafts, matching bearings etc, 320H provides the necessary forces needed for low speeds combined with high power, and is designed to handle irregular loadings in BRUTAL conditions.

STANDARD SPECIFICATION of Motorized Pulley

- Crowned mild steel Ø 320 mm steel shell treated with anti-rust wax
- Powder coated cast iron bearing housings
- Mild steel shafts treated with anti-rust wax
- Shaft sealing system – degree of protection IP66/67 (EN60034-5)
- Compact powder coated die cast aluminium terminal box ≤=4.0 kW
- Larger Powder coated die cast aluminium terminal box ≥=5.5 kW
- 3-phase induction motors with thermal protector
- Voltage: wide range 3-phase single voltage. Most common voltages available. Please specify!
- Motor winding insulation Class F
- Dynamically balanced rotor
- One out of two oil plugs fitted with a magnet to filter the oil – 320L
- Two oil plugs fitted with a magnet to filter the oil – 320M & 320H
- Oil change recommended every 20.000 operational hours
- Minimum RL. Please refer to pages 33-34
- Maximum RL – Please inquire!
- Non standard RL's available
- To be used in horizontal positions ± 5 degree only!

Please note:

- Straight or elbow connector available
- Parallel shell available. Diameter equal to dimension Ø A
- Two speed motors on request
- Special speed available on request
- Motorized Pulleys for non-horizontal positions available on request
- The high speed of 2-pole motors can cause higher noise levels and are therefore not recommended in noise sensitive areas

STAINLESS STEEL options

TS9N

- Stainless steel shell – AISI 304 range
- Stainless steel shafts – AISI 303/4 range
- Stainless steel covered bearing housings – AISI 316 range
- Stainless steel oil plugs – AISI 304 range – one out of two with magnet
- Stainless steel exterior bolts – AISI 304 range
- Re-greasable labyrinth seals with grease nipples in stainless steel – AISI 304 range
- Shaft sealing system – degree of protection IP66/67 (EN60034-5).

TS10N

- As TS9N, but WITHOUT re-greasable labyrinth seals.

SEMI-RUST-FREE options

TS11N

- As TS9N, but with crowned mild steel Ø 320 mm steel shell treated with anti-rust wax.

TS12N

- As TS10N, but with crowned mild steel Ø 320 mm steel shell treated with anti-rust wax.

Other Options:

- FDA & USDA food grade recognized oil and grease are NOT included in TS9N to TS12N, but available on request
- Complete Motorized Pulleys in acid resistant stainless steel – AISI 316 range – on request.

Electrical connection options:

- Salt water resistant powder coated aluminium terminal box with zinc plated exterior bolts
- Stainless steel terminal box – AISI 304 range (max. 4 kW)
- Straight stainless steel connector with flying lead – AISI 304 range.

When ordering, please specify the required voltage, electrical connection and eventual TS-number, options, brackets and idler pulleys.

- Environmental considerations: page 77-78
- Technical precautions: pages 81-92
- Optional extras: page 31 and back cover
- Connection Diagrams: pages 98-100.



OPTIONAL EXTRAS

Motorized Pulley 320L, 320M & 320H

Specification	320L	320M & 320H
Total stainless steel option AISI 304 range TS9N Re-greasable labyrinth seals!	x	x
Total stainless steel option AISI 304 range TS10N Standard seals!	x	x
Semi-rust-free option TS11N Re-greasable labyrinth seals!	x	x
Semi-rust-free option TS12N Standard seals!	x	x
Food grade oil & grease - FDA & USDA recognized - available on request	x	x
Dust explosion proof Motorized Pulleys - ATEX 95 - Zone 22 - for applications handling of dusty grain etc. According to European Directive 94/9/EC.	On request!	On request!
TOTAL acid resistant stainless steel option - AISI 316	x	x
Re-greasable labyrinth seals - mild steel	x	x
Black rubber lagging - STANDARD specifications: - Smooth lagging - Hardness 60 ±5 Shore A - Diamond lagging - Hardness 60 ±5 Shore A	o 5/8 mm 6/8 mm	o 5/8 mm 6/8 mm
White smooth rubber lagging (FDA). Oil, fat & grease resistant	x	x
SPECIAL lagging available on request - e.g. hot vulcanized, ceramic etc.	x	x
Electromagnetic brake	x	x
Min. RL dimensions increases by (mm)	100	100
Mechanical backstop	x	x
Min. RL dimensions increases by (mm)		50
Modified for vertical mounting	o	o
Modified for mounting between 5° - ≤ 90° - e.g. for magnetic separators	o	o
Insulation class F - Allowable ambient temperature: -25°C-+40°C	Std.	Std.
Insulation class H with synthetic oil	x	x
SPECIAL motors for applications with NO belt contact	x	x
Low noise drives for noise sensitive areas	x	x
Parallel shell	x	x
Thermal protector	Std.	Std.
IP66/67 Compact powder coated aluminium terminal box - food grade approved	Std.	Std. ≤ 4.0 kW
IP66/67 Compact stainless steel - AISI 304 or 316 range - terminal box	x	≤ 4.0 kW
IP66/67 Larger powder coated aluminium terminal box - food grade approved		Std. ≥ 5.5 kW
Straight or elbow connector with flying lead	x	≤ 4.0 kW
Straight connector with flying lead - Stainless steel - AISI 304 range -	x	≤ 4.0 kW
Shaft sealing system - degree of protection IP66/67 (EN60034-5)	Std.	Std.
Screened cables - a MUST together with Frequency Converters	x	x
3-phase single voltage (3 x 400V) or (3 x 690V) 50Hz +/- 10% - DIN IEC 38	Std.	Std.
Euro wide range voltage (3 x 380-415V 50 Hz) with +/-10% tolerance - DIN IEC 38 or (3 x 660-690V 50 Hz)	x	x
Special voltages - 50 and/or 60 Hz Please specify!	x	x
Dual voltage - delta/star - connection!	x	x
CSA approved motors - available on request only!	x	x

x = Optional extra's

o = An option with certain limitations. Please refer to Technical precautions pages 81-92!

Std. = Fitted as standard

Motorized Pulley 320L, 320M & 320H, Ø 320 mm

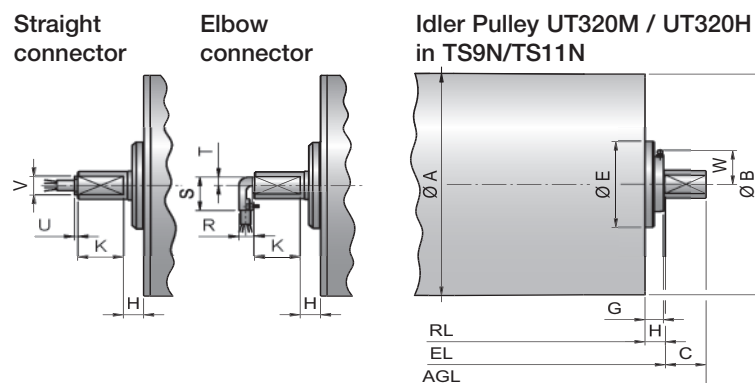
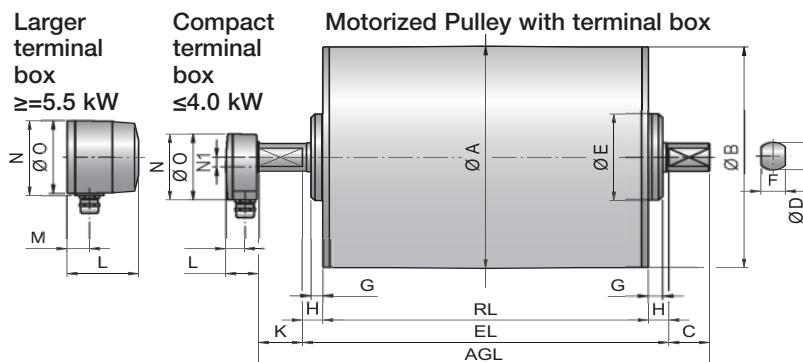

Type	Motorized Pulley or idler Pulley (UT)											Compact terminal box ≤4.0 kW				Larger terminal box ≥5.5 kW				Straight connector ≤4.0 kW		Elbow connector ≤4.0 kW		
	A	B	C	D	E	F	G	TS9/11	H	K	W	L	M	N	N1	L	M	N	O	U	V	R	S	T
	mm	mm	mm	mm	mm	mm	mm	mm	mm	mm	mm	mm	mm	mm	mm	mm	mm	mm	mm	mm	mm	mm	mm	mm
320L	323	319	50	40	96	30	15	19.5	25	54	-	41	24	95	14	-	-	-	-	4	27	20	48	12
320M	321	319	50	40	125	30	17.5	22.5	25	54	-	41	24	95	14	87	27	107	105	4	27	20	48	12
320H	321	319	50	50	148	40	11	20.5	25	54	-	41	24	95	14	87	27	107	105	4	27	20	48	12
UT320M	321	319	50	40	125	30	14.5	22.5	25	-	52	→ Idler Pulley shown in TS9N/TS11N version with re-greasable seals												
UT320H	321	319	50	50	148	40	11	20.5	25	-	52	→ Idler Pulley shown in TS9N/TS11N version with re-greasable seals												

Mounting brackets KL41-HD & KL42

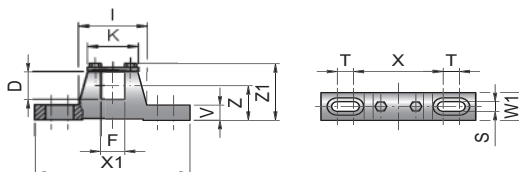

Motorized Pulleys Type	Material	Bracket description	Dimensions												Weight kg
			D	F	I	K	S	T	V	W1	X	X1	Z	Z1	
			mm	mm	mm	mm	mm	mm	mm	mm	mm	mm	mm	mm	mm
320L & 320M	Steel	KL41-HD	40	30	84	62	14	20	22	40	110	190	50	83	2.1
320H	Steel	KL42	50	40	121	90	18	30	25	50	150	250	70	110	4.5



Motorized Pulley 320L, Ø 320 mm

50 Hz

Motor			Nominal belt speed at Full Load 50Hz m/sec	Torque Nm	Belt Pull N	Max. Radial Load T1+T2 N	Special min. RL	Type	Weight in kg for STANDARD width											Type of Bracket
Power kW/HP	No. of Poles	Gear stages							Dimension RL in mm (RL >2000 mm available on request)											
									400	450	500	550	600	650	700	750	800	850	per 50 mm up to 2000	
0.75/1.00	8	2	0.32	356	2218	11500	450	320L	78	82	86	90	94	98	102	106	110	4 kg	KL41-HD	
			0.40	285	1776															
			0.50	228	1421															
			0.63	181	1128															
			0.80	142	885															
			1.00	114	710															
			1.25	92	573															
1.10/1.50	4	2	0.63	265	1651	11500	400	320L	73	76	80	84	88	92	96	100	104	108	4 kg	KL41-HD
			0.80	209	1302															
			1.00	167	1040															
			1.25	134	835															
			1.60	105	654															
			2.00	84	524															
			2.50	67	417															
1.50/2.00	4	2	0.63	362	2255	11500	400	320L	75	78	82	86	90	94	98	102	106	110	4 kg	KL41-HD
			0.80	285	1776															
			1.00	228	1421															
			1.25	182	1134															
			1.60	143	891															
			2.00	114	710															
			2.50	92	573															
2.20/3.00	4	2	0.80	418	2604	11500	450	320L	82	86	90	94	98	102	106	110	114	4 kg	KL41-HD	
			1.00	334	2081															
			1.25	265	1651															
			1.60	209	1302															
			2.00	167	1040															
			2.50	134	835															
			3.00/4.00	4	2															1.25
1.60	285	1776																		
2.00	228	1421																		
2.50	182	1134																		
2.50	182	1134																		
4.00/5.50	2	2	1.60	380	2368	11500	500	320L	90	94	98	102	106	110	114	118	4kg	KL41-HD		
			2.00	304	1894															
			2.50	243	1514															

Motorized Pulley 320M & 320H, Ø 320 mm

50 Hz

Motor			Nominal belt speed at Full Load 50Hz m/sec	Torque Nm	Belt Pull N	Max. Radial Load T1+T2 N	Special min. RL	Type	Weight in kg for STANDARD width											Type of Bracket											
Power kW/HP	No. of Poles	Gear stages							Dimension RL in mm (RL >2000 mm available on request)																						
									450	500	550	600	650	700	750	800	850	per 50 mm up to 2000													
0.75/1.00	12	3	0.13	876	5475	35000	550	320H	135	139	144	149	154	159	164	5 kg	KL42-HD														
			0.16	712	4453																										
			0.20	570	3562																										
		0.75/1.00	12	2	0.25	456	2841	20000	500	320M	110	114	118	122	126	130	134	138	4 kg	KL41-HD											
					0.32	356	2218																								
					0.40	285	1776																								
					0.50	228	1421																								
0.63	181				1128																										
0.80	142				885																										
1.10/1.50	12				3	0.13	1286														8039	35000	550	320H	135	139	144	149	154	159	164
		0.16	1045	6531																											
		8	2	0.20	836	5225	20000	500	320M	110	114	118	122	126	130	134	138	4 kg	KL41-HD												
				0.25	669	4181																									
				0.32	522	3252																									
	1.10/1.50	8	2	0.40	418	2604	20000	500	320M	110	114	118	122	126	130	134	138	4 kg	KL41-HD												
				0.50	334	2081																									
				0.63	265	1651																									
				0.80	209	1302																									
				1.00	167	1040																									
1.25	134	835																													

Idler Pulley	20000	450	UT320M	50	54	58	62	66	70	74	78	82	4 kg	KL41-HD
		35000	450	UT320H	50	61	65	69	73	77	81	85	89	4 kg



Motorized Pulley 320M & 320H, Ø 320 mm

50 Hz

Power kW/HP	Motor		Nominal belt speed at Full Load 50Hz m/sec	Torque Nm	Belt Pull N	Max. Radial Load T1+T2 N	Special min. RL	Type	Weight in kg for STANDARD width											Type of Bracket														
	No. of Poles	Gear stages							Dimension RL in mm (RL >2000 mm available on request)																									
									450	500	550	600	650	700	750	800	850	per 50 mm up to 2000																
1.50/ 2.00	8	3	0.16	1425	8906	35000	550	320H	[shaded]	[shaded]	135	139	144	149	154	159	164	5 kg	KL42-HD															
			0.20	1140	7125																													
		0.25	912	5700																														
	1.50/ 2.00	8	2	0.32	712	4436	20000	500	320M	[shaded]	110	114	118	122	126	130	134	138	4 kg	KL41-HD														
				0.40	570	3551																												
				0.50	456	2841																												
			2.20/ 3.00	8	3	0.63														362	2255	20000	500	320M	[shaded]	110	114	118	122	126	130	134	138	4 kg
0.80						285														1776														
1.00					228	1421																												
2.20/ 3.00				8	3	1.25														182	1134													
	0.20	1672				10450																												
	0.25	1338			8362																													
	2.20/ 3.00	8		2	0.32	1045	6531	20000	500	320M	[shaded]	110	114	118	122	126	130	134	138	4 kg	KL41-HD													
			0.40		836	5225																												
			0.50	669	4181																													
		3.00/ 4.00	4	2	0.63	522	3252														20000	500	320M	[shaded]	100	104	108	112	116	120	124	128	4 kg	KL41-HD
0.80					418	2604																												
1.00				334	2081																													
3.00/ 4.00			6	3	1.25	265	1651																											35000
	1.60				209	1302																												
	2.00			167	1040																													
	3.00/ 4.00		4	2	2.50	134	835	20000	500	320M	[shaded]	100	104	108	112	116	120	124	128	4 kg														
		0.25			1824	11400																												
		0.32		1425	8906																													
		4.00/ 5.50	6	3	0.40	1140	7125														35000	550	320H	[shaded]	[shaded]	135	139	144	149	154	159	164	5 kg	
0.50					912	5700																												
0.63				727	4525																													
4.00/ 5.50			4	2	0.80	570	3562																											20000
	1.00				456	2841																												
	1.25			362	2255																													
	4.00/ 5.50		4	2	1.60	285	1776	20000	500	320M	[shaded]	110	114	118	122	126	130	134	138	4 kg														
		2.00			228	1421																												
		2.50		182	1134																													
		5.50/ 7.50	6	3	2.50	134	835														35000	550	320H	[shaded]	[shaded]	135	139	144	149	154	159	164	5 kg	
0.32					1900	11875																												
0.40				1520	9499																													
5.50/ 7.50			4	2	0.50	1216	7600																											20000
	0.63				965	6031																												
	0.80			760	4735																													
	5.50/ 7.50		4	2	1.00	608	3788	20000	500	320M	[shaded]	110	114	118	122	126	130	134	138	4 kg														
		1.25			486	3028																												
		1.60		380	2368																													
		7.50/ 10.00	6	3	2.00	304	1894														35000	550	320H	[shaded]	[shaded]	135	139	144	149	154	159	164	5 kg	
2.50					243	1514																												
0.40				2090	13062																													
7.50/ 10.00			4	2	0.50	1672	10450																											20000
	0.63				1327	8294																												
	0.80			1045	6531																													
	7.50/ 10.00		2	3	1.00	836	5225	35000	550	320H	[shaded]	[shaded]	135	139	144	149	154	159	164	5 kg														
		1.25			1140	7125																												
		1.60		911	5700																													
		7.50/ 10.00	2	2	2.00	712	4453														20000	500	320M	[shaded]	110	114	118	144	149	154	159	164	4 kg	
2.50					570	3562																												
2.50				456	2850																													
11.00/ 15.00			2	3	1.00	1672	10450																											35000
	1.25				1327	8294																												
	1.60			1045	6531																													
	2.00		836	5225																														
	2.50	671	4180																															
11.00/ 15.00	2	2	2.50	671	4180	20000	800	320M	[shaded]	[shaded]	[shaded]	[shaded]	[shaded]	[shaded]	[shaded]	[shaded]	[shaded]	[shaded]	[shaded]	[shaded]														
			Note for: 11kW: min. RL 1100																		178	182	5 kg	KL42-HD										
											173	178	4 kg	KL41-HD																				

Idler Pulley		20000	450	UT320M	50	54	58	62	66	70	74	78	82	4 kg	KL41-HD
		35000	450	UT320H	57	61	65	69	73	77	81	85	89	4 kg	KL42-HD

Motorized Pulley 320L, Ø 320 mm

Spare parts list and sectional drawings

Pos.	Description	Pos.	Description	Pos.	Description
1	Shell	24	2 Dust lip seals each side	78	Gasket
2	End housing with geared rim	24	1 Double lip seal for labyrinth option	79	Holding clip or plastic tie
3	End housing	25	O-ring	85.1	Intermediate flange for brake assembly
8	Geared rim	26	Bearing	91	Electromagnetic brake
9	Rotor pinion	27	Bearing	93	Retaining ring
10	Input wheel	28	Bearing	95	Straight connector
11	Output pinion	29	Bearing (Backstop solution: One-way-bearing)	96	Elbow connector
12	Gear box	30	Bearing	101	Key
13	Front shaft	31	Bearing	104	Distance washer
14	Rear shaft	39	Hexagon socket screw	120	Labyrinth cover
15	Stator complete	40	Hexagon socket screw	121	Set screw
15.1	Rotor	52	Magnetic oil plug	122	O-ring
16	Terminal box complete	53	Distance washer	123	Grease nipple
17	Nipple	53.1	Compression nipple	124	Washer
20	Cover	59	Countersunk head screw	143	O-ring
20.1	Cover with labyrinth groove	66	Waved spring washer	146	Special shaped compression washer
23	Rear flange	68	Key	200	Rubber seal
23.1	Rear flange for backstop	70	Toothed washer	202	Motor data plate
23.2	Rear flange for electromagnetic brake				

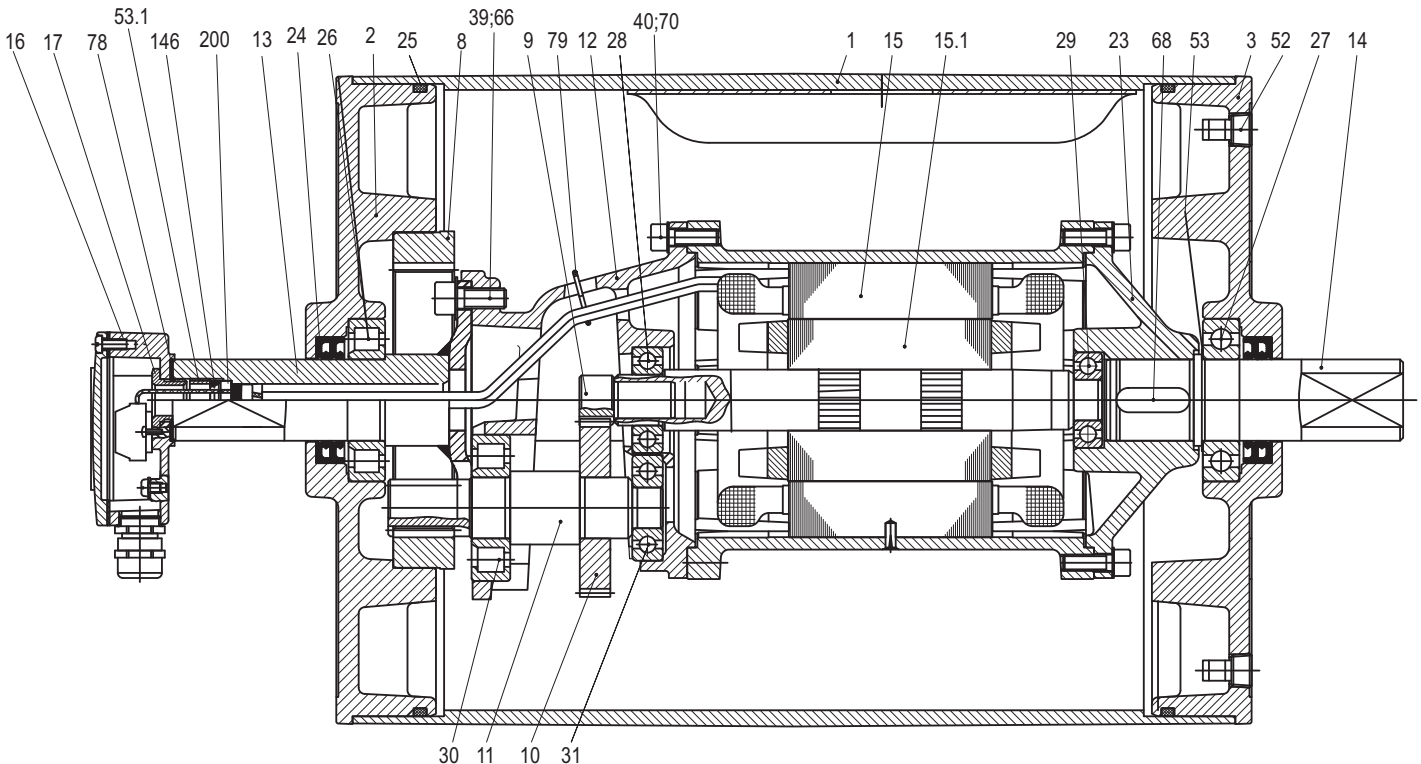



Motorized Pulley 320M, Ø 320 mm

Spare parts list and sectional drawings

Pos.	Description	Pos.	Description	Pos.	Description
1	Shell	28	Bearing	70	Toothed washer
2	End housing with geared rim	29	Bearing	75	Gasket
3	End housing	30	Bearing	78	Gasket
8	Geared rim	30	Bearing	79	Holding clip or plastic tie
9	Rotor pinion	31	Bearing	81	Rotor pinion shaft
10	Input wheel	32	Retaining ring	85	Intermediate flange for backstop
11	Output pinion	33	Retaining ring	85.1	Intermediate flange for brake assembly
12	Gear box	35	Retaining ring	90	Backstop
13	Front shaft	37	Hexagon head screw	91	Electromagnetic brake
14	Rear shaft	43	Hexagon head screw	93	Retaining ring
15	Stator complete	44	Hexagon head screw	94	Hexagon head screw
15.1	Rotor	45	Hexagon head screw	95	Straight connector
16	Terminal box complete	46	Hexagon head screw	96	Elbow connector
17	Nipple	52	Magnetic oil plug	99	Waved spring washer
20	Cover	53	Distance washer	101	Key
20.1	Cover with labyrinth groove	53.1	Compression nipple	104	Distance washer
23	Rear flange	60	Parallel pin	120	Labyrinth cover
23.1	Rear flange for backstop/Brake	64	Prevailing torque type hexagon nut	121	Set screw
24	2 Dust lip seals each side	66	Waved spring washer	122	O-ring
25	O-ring	67	Toothed washer	123	Grease nipple
26	Bearing	68	Key	143	O-ring
27	Bearing	69	Key	146	Special shaped compression washer
				200	Rubber seal

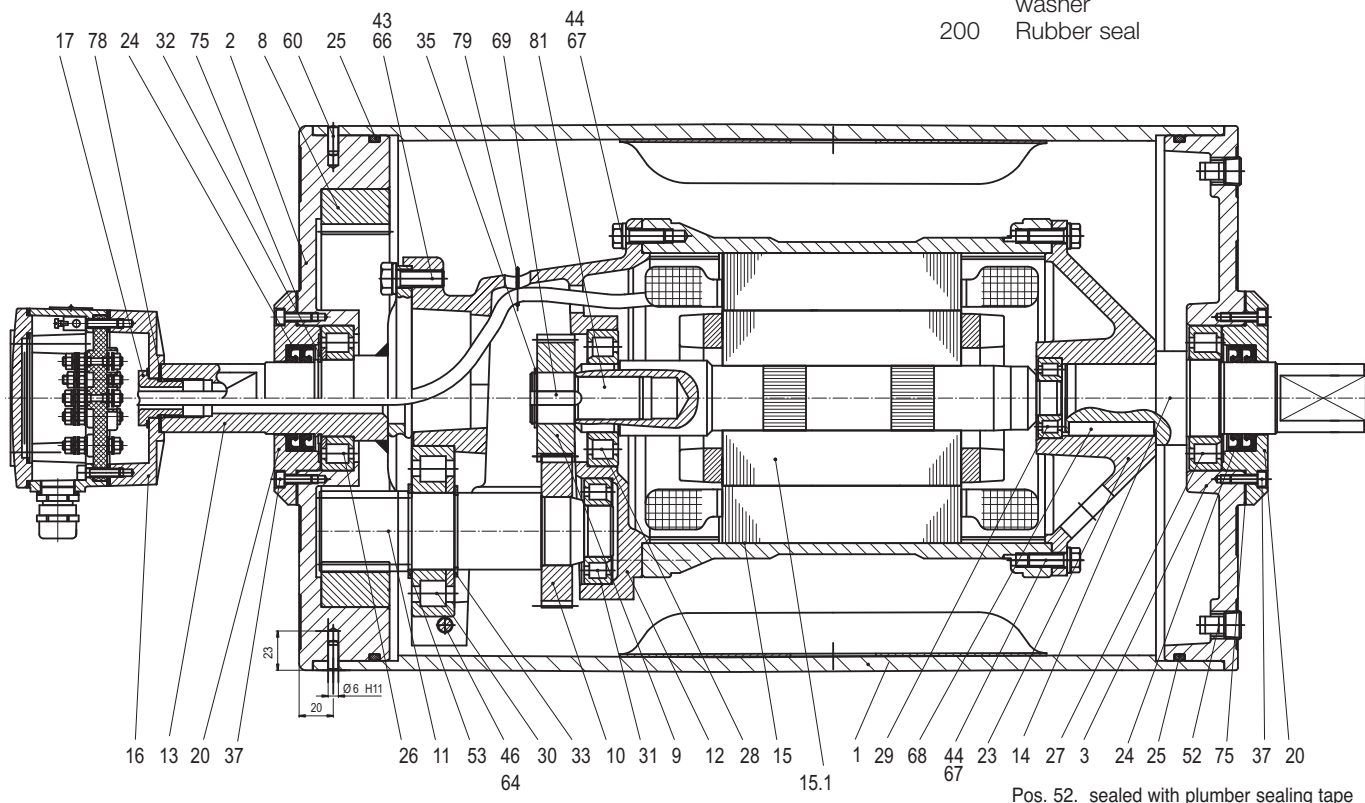

Pos. 52. sealed with plumber sealing tape

Motorized Pulley 320H, Ø 320 mm

Spare parts list and sectional drawings

Pos.	Description	Pos.	Description	Pos.	Description
1	Shell	90	Backstop	184	Bearing
2	End housing with geared rim	91	Electromagnetic brake	185	Bearing
3	End housing	93	Retaining ring	186	Key
8	Geared rim	94	Hexagon head screw	187	Key
9	Rotor pinion	95	Straight connector	188	Retaining ring
10	Input wheel	96	Elbow connector	189	Retaining ring
11	Output pinion	99	Waved spring washer	190	Retaining ring
12	Gear box	101	Key	191	Retaining ring
13	Front shaft	104	Distance washer	192	Retaining ring
14	Rear shaft	120	Labyrinth cover	193	Distance washer
15	Stator complete	121	Set screw	194	Set screw
15.1	Rotor	122	O-ring	195	Prevailing torque type hexagon nut
16	Terminal box complete	123	Grease nipple	196	Key
17	Nipple	143	O-ring	197	Retaining ring
20	Cover front side	146	Special compression washer	198	Distance ring
20.1	Cover with labyrinth groove	180	Intermediate pinion shaft	199	Bushing (inner race of the needle roller bearing)
21	Cover – rear side	181	Intermediate pinion	200	Rubber seal
21.1	Cover with labyrinth groove	182	Distance bushing	201	Hexagon head screw
23	Rear flange	183	Washer		
23.1	Rear flange for brake option				
24	2 Dust lip seals each side				
25	O-ring				
26	Bearing				
27	Bearing				
28	Bearing				
29	Bearing				
30	Bearing				
31	Bearing				
32	Retaining ring				
33	Retaining ring				
35	Retaining ring				
37	Hexagon socket screw				
38	Hexagon socket screw				
43	Hexagon socket screw				
44	Hexagon socket screw				
45	Hexagon socket screw				
52	Magnetic oil plug				
53.1	Compression nipple				
60	Parallel pin				
67	Toothed washer				
68	Key				
70	Toothed washer				
73	Set screw				
75	Gasket				
78	Gasket				
79	Holding clip or plastic tie				
80	Hexagon head screw				
84	Rear flange for brake				
85	Intermediate flange for backstop				
85.1	Intermediate flange for brake assembly				

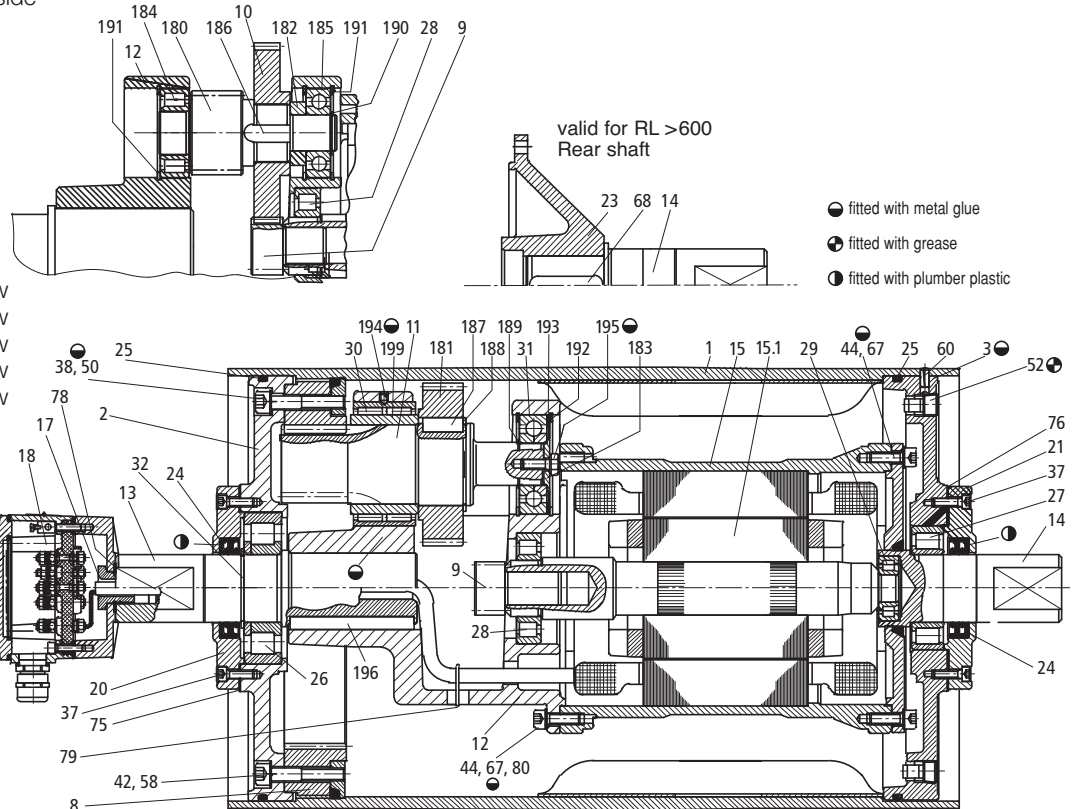

Motorized Pulley 320L, 320M & 320H, Ø 320 mm

Sectional drawings

Re-greasable Labyrinth Option

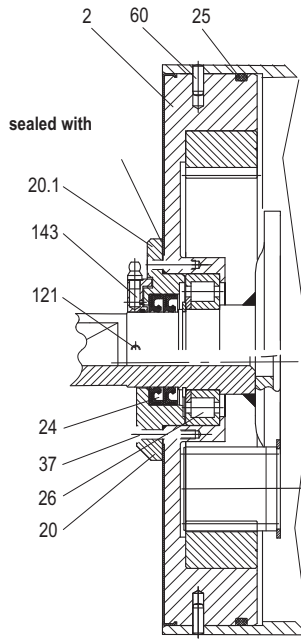
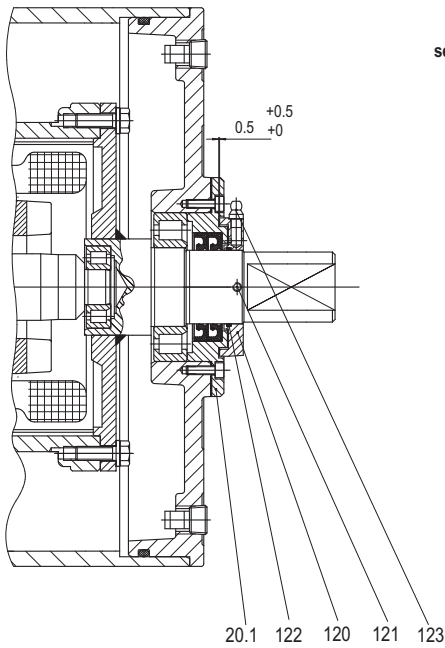

TS9N + TS11N
Labyrinth Option
valid for 320M

the pos. no. in brackets
(21 & 21.1) is valid for
320H 3-stage

TS10N + TS11N
without labyrinth

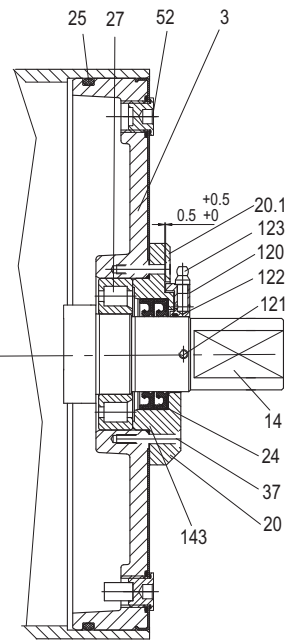

Stainless Steel Option

320L TS9N

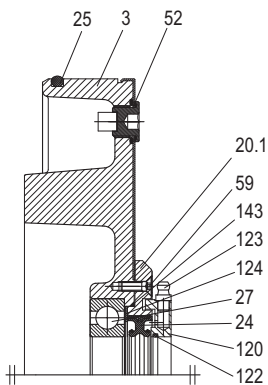

Elbow Connector

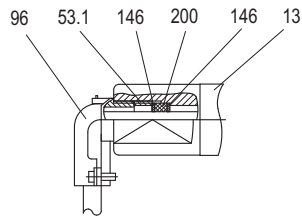

Straight Connector

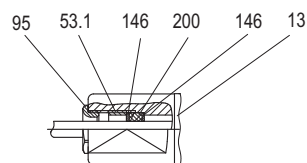

Electromagnetic Brake Option

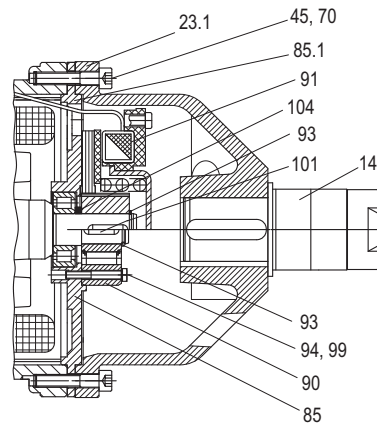

Backstop Option

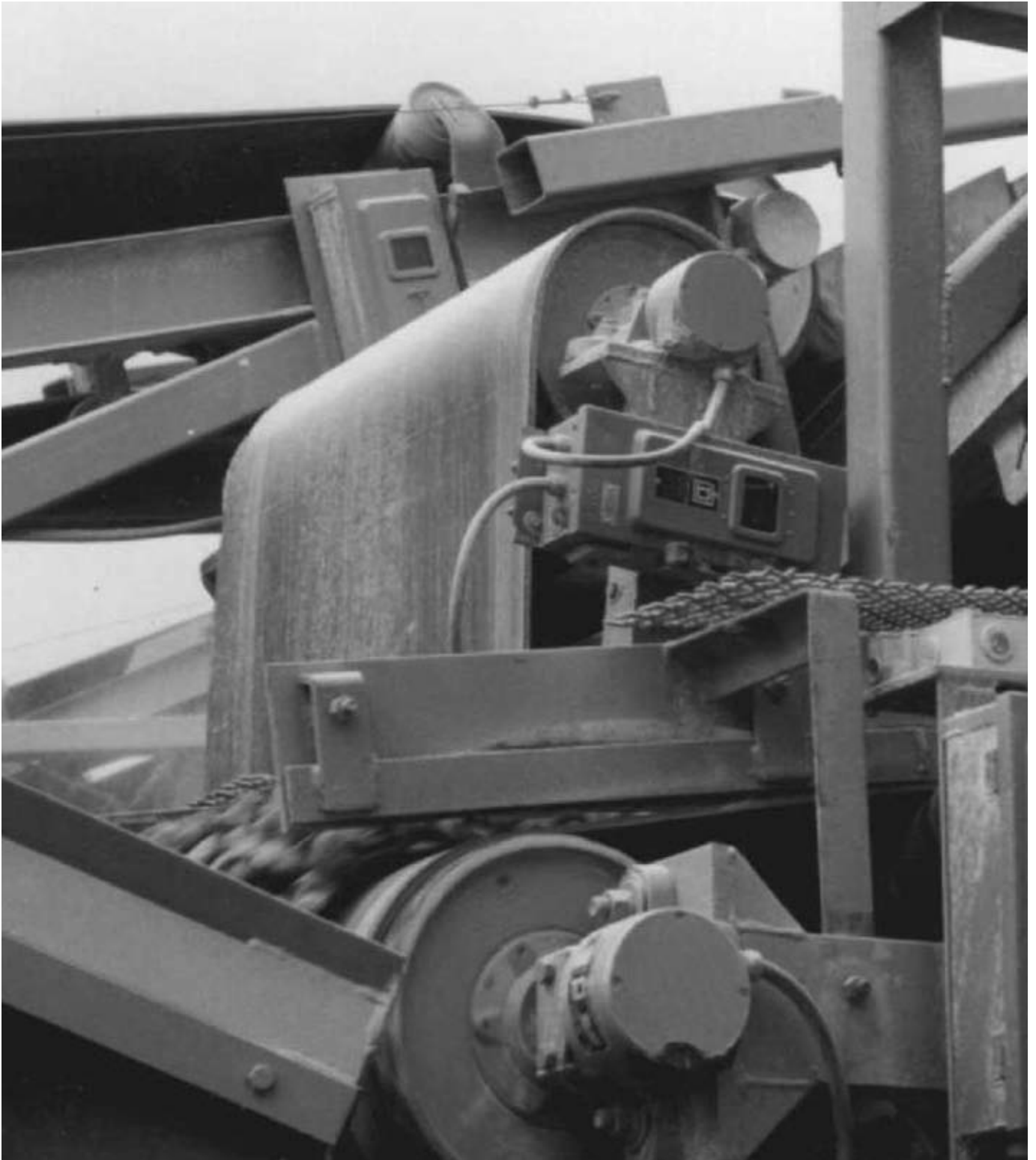

Rulmecca Motorized Pulleys in mobile Crushing & Screening. Features: Compact, reliable and requires NO maintenance!



Motorized Pulley 400L, 400M & 400H, Ø 400 mm

To match your requirements in diameter 400 mm, our product range offers three different loading performances for your BULK applications:

- L for Light-duty
- M for Medium-duty
- H for Heavy-duty

You have a choice.

Therefore, it is important to notice the differences to choose the right type of pulley for the right application based on estimated belt tension (radial load) = T1+T2. The actual radial load **MUST** be **LESS** than the max. allowable radial load shown in this catalogue.

Be aware of increased belt tensions using **multi-ply thick heavy belts** and/or larger belt widths.

If you do not find the belt tension needed in this diameter, you might have to choose a larger one.

L for Light-duty

400L is meant for applications with regular and constant operating conditions. Max. allowable radial load has to be respected. A popular application is magnetic separators! (Motor/gearbox origin from 320M).

M for Medium-duty

The internal parts of 400M are designed for tough, irregular and extreme working conditions.

400M are typically used in grain storage, cement, steel, fertilities and heavy mobile crushing & screening applications.

H for Heavy-duty

Due to a solid 3-stage gearbox, 400H provides the necessary forces needed for low speeds, combined with high power, and is designed to handle irregular loadings in BRUTAL conditions.

STANDARD SPECIFICATION of Motorized Pulley

- Crowned mild steel Ø 400 mm steel shell painted yellow – min. layer of 60 µm
- Bolted powder coated cast iron bearing housings and covers, all painted yellow – min. layer of 60µm
- Mild steel shafts treated with anti-rust wax
- Shaft sealing system - degree of protection IP66/67 (EN60034-5)
- Powder coated aluminium terminal box – 400L
- Cast iron terminal box 400M & 400H painted yellow – min. layer of 60µm
- 3-phase induction motors with thermal protector
- Voltage: 3-phase single voltage. Most common voltages available. Please specify!
- Motor winding insulation Class F
- Dynamically balanced rotor
- Two oil plugs each fitted with a magnet to filter the oil
- Oil change recommended every 20.000 operational hours
- Minimum RL. Please refer to pages 43-44
- Maximum RL – Please inquire!
- Non standard RL's available
- To be used in horizontal positions ±5 degree only!

Please note:

- Straight or elbow connector available – 400L ≤4.0 kW
- Special speeds available on request.
- Parallel shell available. Diameter equal to dimension Ø A.
- Motorized Pulleys for non-horizontal positions available on request.

STAINLESS STEEL options

TS9N

- Stainless steel shell – AISI 304 range
- Stainless steel shafts – AISI 303/4 range
- Stainless steel covered bearing housings – AISI 316 range
- Re-greasable bearing covers with labyrinth grooves and labyrinth seals with grease nipples in stainless steel – AISI 304 range

- Stainless steel oil plugs – AISI 304 range – one out of two with magnet
- Stainless steel exterior bolts – AISI 304 range
- Shaft sealing system – degree of protection IP66/67 (EN60034-5)

TS10N

- As TS9, but WITHOUT re-greasable labyrinth seals

SEMI-RUST-FREE options

TS11N

- Painted mild steel shell – min. layer of 120 µm
- Stainless steel shafts – AISI 303/4 range
- Stainless steel covered cast iron bearing housing – AISI 316 range
- Re-greasable bearing covers with labyrinth grooves and grease nipples in stainless steel
- Zinc plated oil plugs one out of two with magnet
- Zinc plated exterior bolts
- Shaft sealing system – degree of protection IP66/67 (EN60034-5)
- Powder coated terminal box - 400L
- Painted terminal box – min. thickness layer of 120 µm – 400M & 400H

TS12N

- As TS11N, but without re-greasable seals.
- Covers - standard

Other Options:

- FDA & USDA food grade recognized oil and grease are NOT included in TS9N - TS12N, but available on request
- Complete Motorized Pulleys in acid resistant stainless steel – AISI 316 range – on request.

Electrical connection options:

- Salt water resistant powder coated aluminium terminal box with zinc plated exterior bolts
- Stainless steel terminal box – AISI 304 range (400L - ≤4.0 kW only)
- Straight stainless steel connector with flying lead – AISI 304 range - ≤4.0 kW.

When ordering, please specify the required voltage, electrical connection and eventual TS-number, options, brackets and idler pulleys.

- Environmental considerations: page 77-78
- Technical precautions: pages 81-92
- Optional extras: page 41 and back cover
- Connection Diagrams: pages 98-100.



OPTIONAL EXTRAS

Motorized Pulley 400L, 400M & 400H

Specification	400L	400M & 400H
Total stainless steel option AISI 304 range TS9N Re-greasable labyrinth seals!	x	x
Total stainless steel option AISI 304 range TS10N Standard seals!	x	x
Semi-rust-free option TS11N Re-greasable labyrinth seals!	x	x
Semi-rust-free option TS12N Standard seals!	x	x
Food grade oil & grease - FDA & USDA recognized - available on request	x	x
Dust explosion proof Motorized Pulleys - ATEX 95 - Zone 22 - for applications handling of dusty grain etc. According to European Directive 94/9/EC.	On request	On request
TOTAL acid resistant stainless steel option - AISI 316	x	x
Re-greasable labyrinth seals - mild steel	x	x
Black rubber lagging - STANDARD specifications: - Smooth lagging - Hardness 60 ±5 Shore A - Diamond lagging - Hardness 60 ±5 Shore A	o 8 mm 8 mm	o 8 mm 8 mm
White smooth rubber lagging (FDA). Oil, fat & grease resistant	x	x
SPECIAL lagging available on request - e.g. hot vulcanized, ceramic etc.	x	x
Electromagnetic brake	x	x
Min. RL dimensions increases by (mm)	100	100
Mechanical backstop - 400M from RL750mm & 400H from RL800 mm	x	x
Min. RL dimensions increases by (mm)	50	
Modified for vertical mounting	o	
Modified for mounting between 5° - ≤ 90° - e.g. for magnetic separators	o	
Insulation class F - Allowable ambient temperature: -25°C-+40°C	Std.	Std.
Insulation class H with synthetic oil	x	x
Parallel shell	x	x
Thermal protector	Std.	Std.
IP66/67 Compact powder coated aluminium terminal box - food grade approved	Std. ≤ 4.0 kW	
IP66/67 Compact stainless steel - AISI 304 or 316 range - terminal box	≤ 4.0 kW	
IP66/67 Larger powder coated aluminium terminal box - food grade approved	Std. ≥ 5.5 kW	
IP66/67 cast iron terminal box painted yellow		Std.
Straight or elbow connector with flying lead	≤ 4.0 kW	
Straight connector with flying lead - Stainless steel - AISI 304 range -	≤ 4.0 kW	
Shaft sealing system - degree of protection IP66/67 (EN60034-5)	Std.	Std.
Screened cables - a MUST together with Frequency Converters	x	
3-phase single voltage (3 x 400V) or (3 x 690V) 50Hz +/- 10% tolerance - DIN IEC 38	Std.	Std.
Euro wide range voltage (3x220-240V / 380-415V 50 Hz) with +/-10% tolerance - DIN IEC 38 or (3x380-400V / 660-690V 50 Hz) with +/-10% tolerance - DIN IEC 38	x	-
Euro-voltage (3x230/400V or 400/690V 50 Hz) with +/-10% tolerance - DIN IEC 38	Std.	Std.
Special voltages - 50 and/or 60Hz Please specify!	x	x
Dual voltage - delta/star - connection possibility!	x	x
CSA approved motors - available on request only!	x	x

x = Optional extra's

o = An option with certain limitations. Please refer to Technical precautions pages 81-92!

Std. = Fitted as standard

Motorized Pulley 400L, 400M & 400H, Ø 400 mm

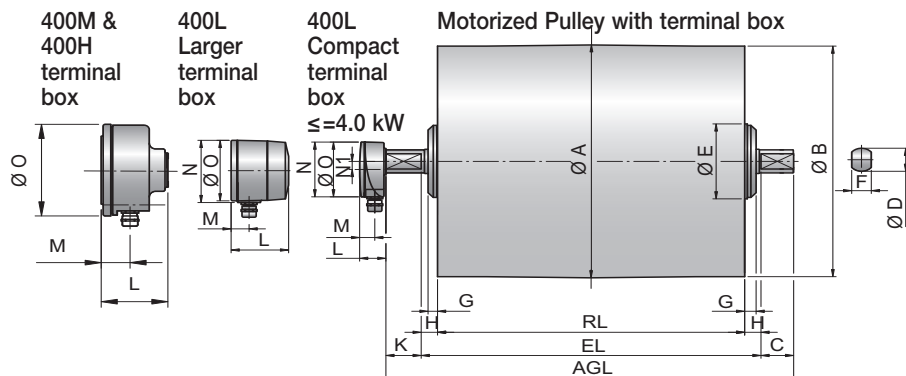

Straight connector

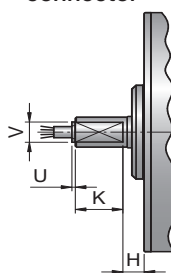

Elbow connector

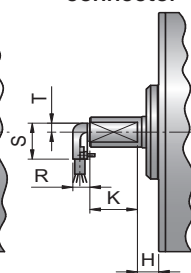

Idler Pulley
UT400L / UT400M / UT400H

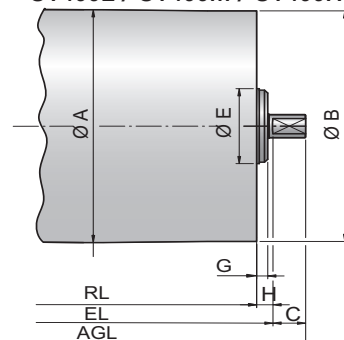

Type	Motorized Pulley or idler Pulley (UT)									Compact terminal box ≤4.0 kW				Larger terminal box ≥5.5 kW				Straight connector ≤4.0 kW		Elbow connector ≤4.0 kW		
	A	B	C	D	E	F	G	H	K	L	M	N	N1	L	M	N	O	U	V	R	S	T
400L	404	400	50	40	125	30	20	25	54	41	24	95	14	87	27	107	105	4	27	20	48	12
400M & 400H	404	400	50	60	194	45	23	25	50	-	-	-	-	100	36.5	-	162	-	-	-	-	-
UT400L	404	400	50	40	125	30	17	25	-													
UT400M & UT400H	404	400	50	60	168	45	20	25	-													

Mounting brackets
KL41-HD & KL60

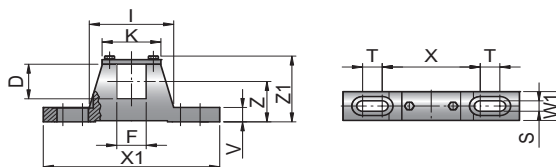

Motorized Pulleys Type	Material	Bracket description	Dimensions												Weight kg
			D	F	I	K	S	T	V	W1	X	X1	Z	Z1	
400L	Steel	KL41-HD	40	30	84	62	14	20	22	40	110	190	50	83	2.1
400M & 400H	Steel	KL60	60	45	132	90	18	30	25	50	150	270	70	115	4.8



Motorized Pulley 400L, Ø 400 mm

50 Hz

Motor			Nominal belt speed at Full Load 50Hz m/sec	Torque Nm	Belt Pull N	Max. Radial Load T1+T2 N	Special min. RL	Type	Weight in kg for STANDARD width												Type of Bracket
Power kW/HP	No. of Poles	Gear stages							Dimension RL in mm (RL >2000 mm available on request)												
									500	550	600	650	700	750	800	850	900	950	1000	per 50 mm up to 2000	
2.20/ 3.00	4	2	0.80	522	2584	20000	500	400L	120	125	130	135	140	145	150	155	160	165	170	5 kg	KL41-HD
			1.00	418	2090																
			1.25	334	1670																
			1.60	265	1325																
			2.00	209	1045																
3.00/ 4.00	4	2	0.80	712	3562	20000	500	400L	130	135	140	145	150	155	160	165	170	175	180	5 kg	KL41-HD
			1.00	570	2850																
			1.25	456	2280																
			1.60	356	1780																
			2.00	285	1425																
4.00/ 5.50	4	2	0.80	950	4750	20000	500	400L	130	135	140	145	150	155	160	165	170	175	180	5 kg	KL41-HD
			1.00	760	3800																
			1.25	608	3040																
			1.60	475	2375																
			2.00	380	1900																
5.50/ 7.50	4	2	1.25	836	4180	20000	500	400L	130	135	140	145	150	155	160	165	170	175	180	5 kg	KL41-HD
			1.60	653	3265																
			2.00	524	2620																
			2.50	418	2090																
7.50/ 10.00	2	2	2.00	712	3525	20000	500	400L	130	135	140	145	150	155	160	165	170	175	180	5 kg	KL41-HD
			2.50	570	2822																
			3.15	452	2238																
Idler Pulley						20000	500	UT400L	80	85	90	95	100	105	110	115	120	125	130	5 kg	KL41-HD

Motorized Pulley 400L, Ø 400 mm

Spare parts list and sectional drawings

Pos.	Description	Pos.	Description	Pos.	Description
1	Shell	30	Bearing	78	Gasket
2	End housing with geared rim	31	Bearing	79	Holding clip or plastic tie
8	Geared rim	32	Retaining ring	85	Intermediate flange for backstop
9	Rotor pinion	33	Retaining ring	85.1	Intermediate flange for brake assembly
10	Input wheel	37	Hexagon socket screw	90	Backstop
11	Output pinion	38	Hexagon socket screw	91	Electromagnetic brake
12	Gear box – cast aluminium	43	Hexagon screw	93	Retaining ring
13	Front shaft	44	Hexagon screw	94	Hexagon head screw
14	Rear shaft	45	Hexagon socket head screw	95	Straight connector
15	Stator complete	46	Hexagon screw	96	Elbow connector
15.1	Rotor	50	Washer	99	Waved spring washer
16	Terminal box complete	52	Magnetic oil plug	101	Key
17	Nipple	53	Distance washer	104	Distance washer
20	Cover	53.1	Compression nipple	120	Labyrinth cover
20.1	Cover with labyrinth groove	64	Prevailing torque type hexagon nut	121	Set screw
23	Rear flange	66	Waved spring washer	122	O-ring
23.1	Rear flange for E-brake	67	Toothed washer	123	Grease nipple
24	2 Dust lip seals each side	68	Key	143	O-ring
26	Bearing	73	Set screw	146	Special compression washer
27	Bearing	75	Gasket	200	Rubber seal
28	Bearing	76	Gasket	202	Motor data plate
29	Bearing	77	Gasket		

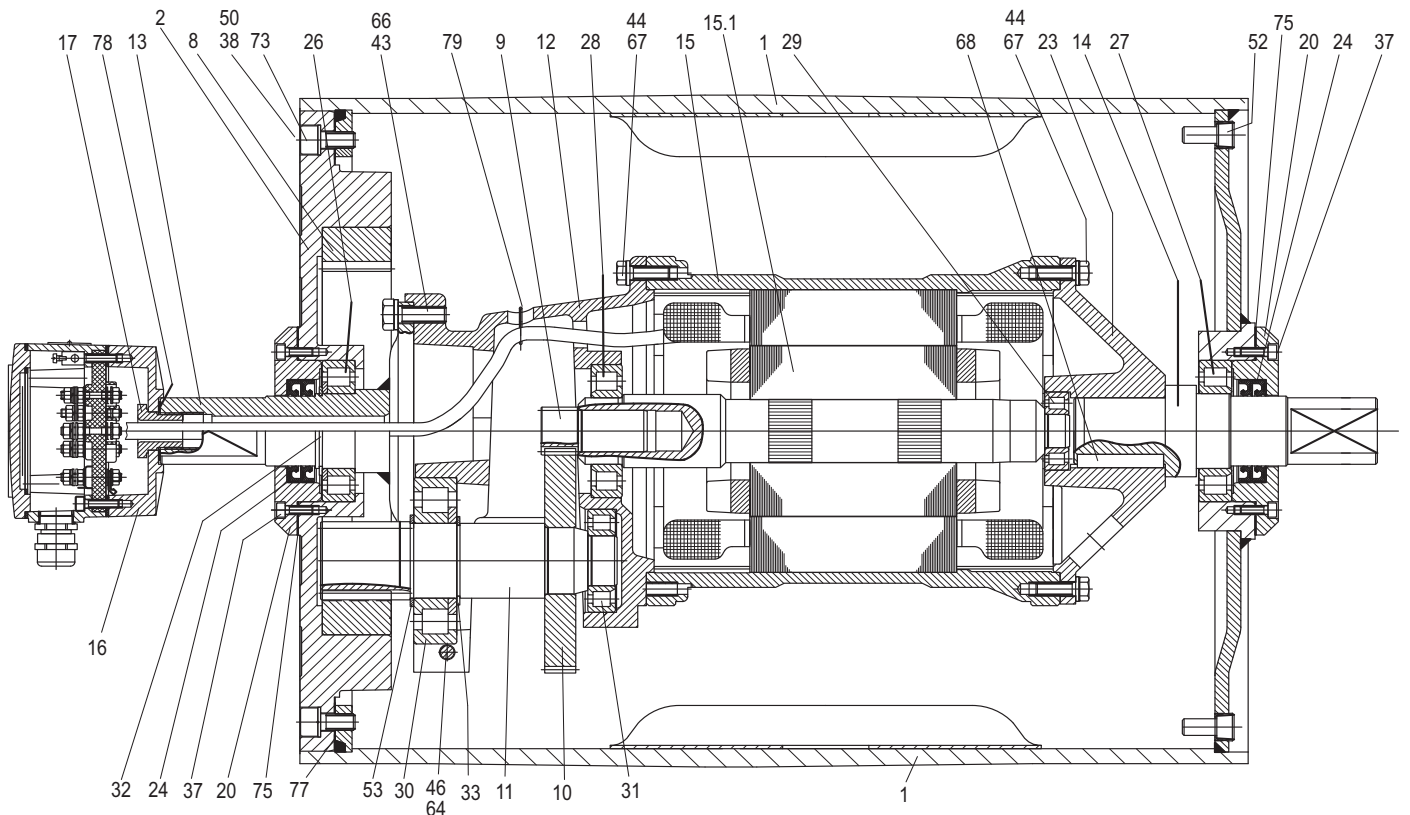

Motorized Pulley 400M, Ø 400 mm

Spare parts list and sectional drawings

Pos.	Description	Pos.	Description	Pos.	Description
1	Shell	26	Bearing	75	Gasket
2	End housing with geared rim	27	Bearing	76	Gasket
8	Geared rim	28	Bearing	77	Gasket
9	Rotor pinion	29	Bearing	78	Gasket
10	Input wheel	30	Bearing	85	Intermediate flange
11	Output pinion	31	Bearing	90	Backstop
12	Gear box – cast aluminium	32	Retaining ring	91	Electromagnetic brake
13	Rear shaft	36	Hexagon socket screw	93	Retaining ring
14	Front shaft	37	Hexagon socket screw	94	Hexagon head screw
15	Stator complete	38	Hexagon socket screw	99	Waved spring washer
15.1	Rotor	43	Hexagon socket screw	101	Key
16	Terminal box complete	44	Hexagon socket screw	104	Distance washer
17	Nipple	50	Washer	120	Labyrinth cover
20	Cover – rear side	52	Magnetic oil plug	121	Set screw
20.1	Cover with labyrinth groove	53	Distance washer	122	O-ring
21	Cover – front side	66	Waved spring washer	123	Grease nipple
21.1	Cover with labyrinth groove	70	Toothed washer	202	Motor data plate
24	2 Dust lip seals each side	73	Set screw		

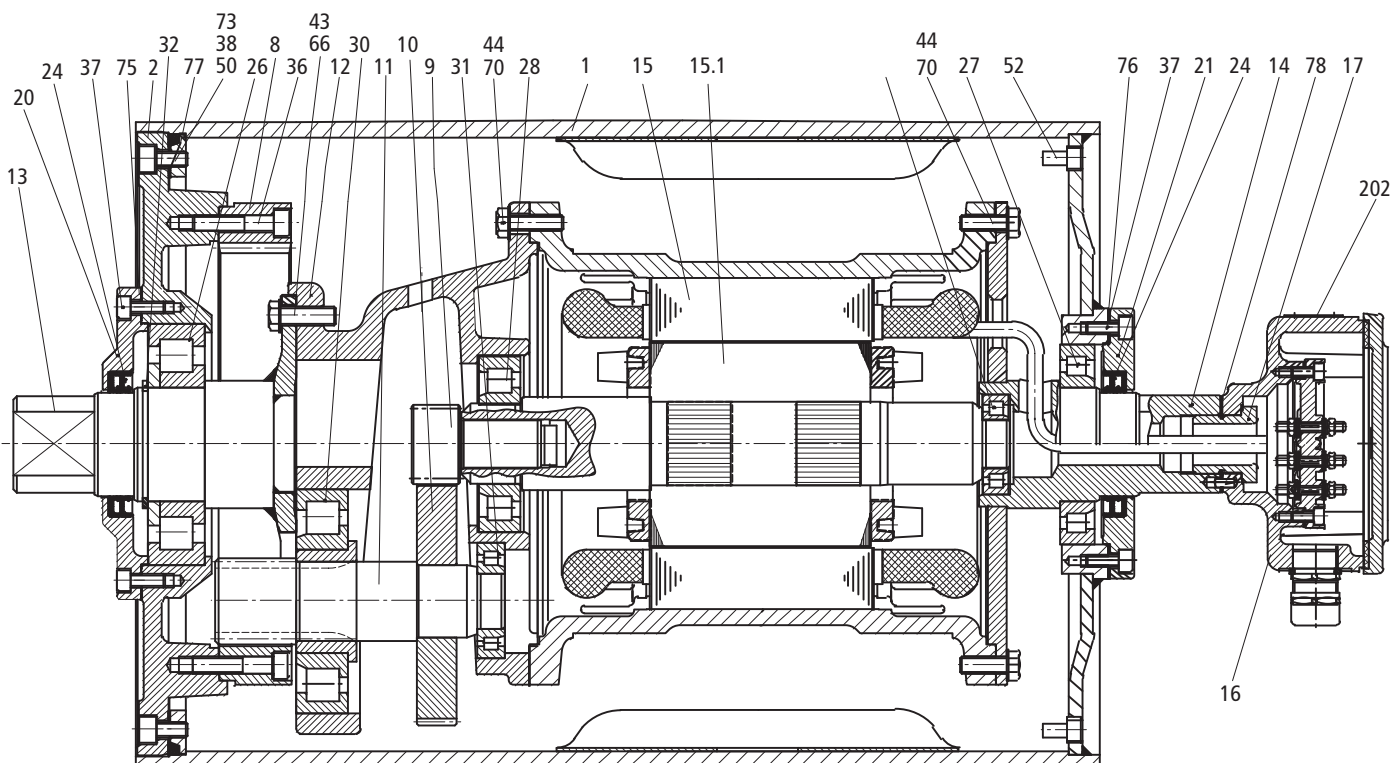

Motorized Pulley 400H, Ø 400 mm

Spare parts list and sectional drawings

Pos.	Description	Pos.	Description	Pos.	Description
1	Shell	20.1	Cover with labyrinth groove	78	Gasket
2	End housing with geared rim	21	Cover front side	85	Intermediate flange for E-brake
8	Geared rim	21.1	Cover with labyrinth groove	90	Backstop
9	Rotor pinion	24	2 Dust lip seals on each side	91	Electromagnetic brake
10	Input wheel	26	Bearing	93	Retaining ring
11	Output pinion	27	Bearing	94	Hexagon head screw
12	Gear box – graphite cast iron	28	Bearing	99	Waved spring washer
13	Rear shaft	29	Bearing	101	Key
14	Front shaft	30	Bearing	104	Distance washer
15	Stator complete	31	Bearing	120	Labyrinth cover
15.1	Rotor	32	Retaining ring	121	Set screw
16	Terminal box complete	37	Hexagon socket screw	122	O-ring
17	Nipple	38	Hexagon socket screw	123	Grease nipple
20	Cover rear side	44	Hexagon socket screw	143	O-ring
		50	Waved spring washer	146	Special compression washer
		52	Magnetic oil plug	180	Intermediate pinion shaft
		53	Distance washer	181	Intermediate pinion
		54	Distance washer	182	Distance bushing
		66	Waved spring washer	184	Bearing
		70	Toothed washer	185	Bearing
		72	Taper grooved pin with internal thread	186	Key
		73	Set screw	187	Key
		75	Gasket	188	Retaining ring
		76	Gasket	196	Key
		77	Gasket	197	Retaining ring
				198	Distance ring
				202	Motor data plate

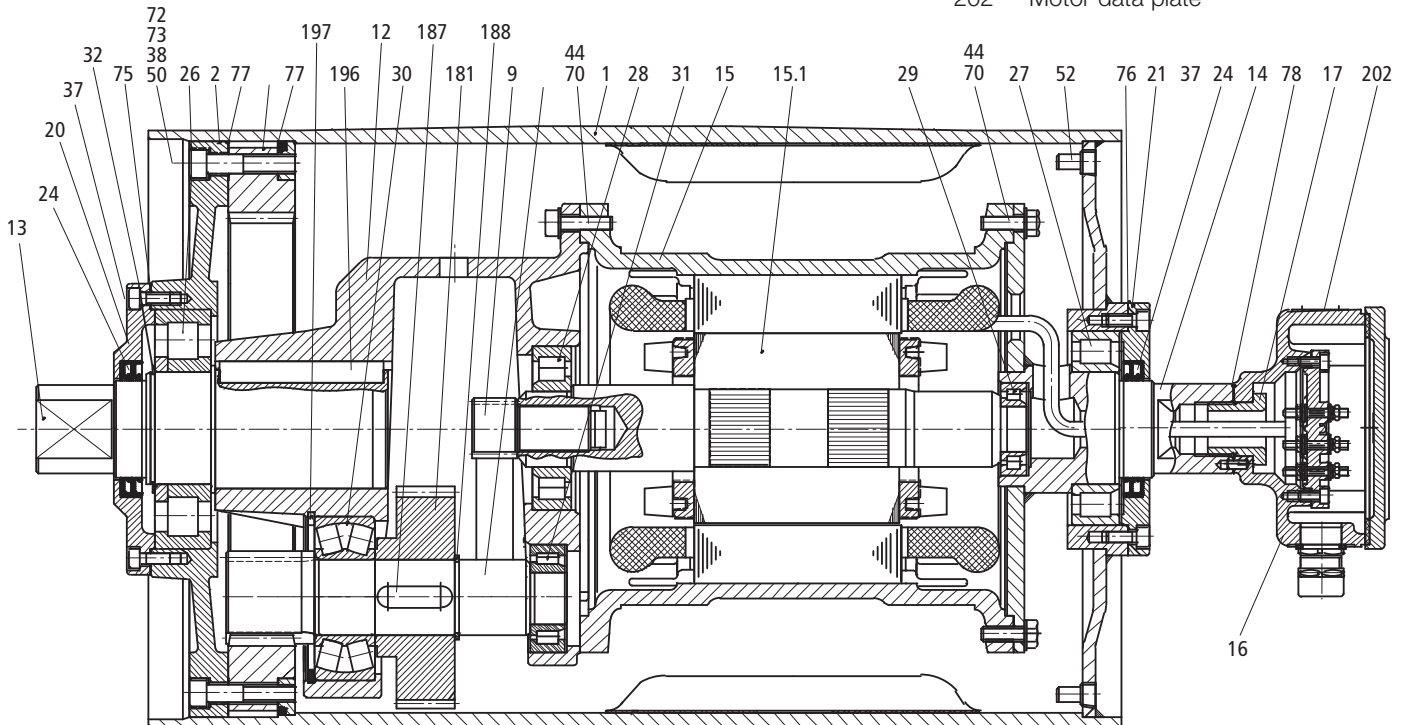
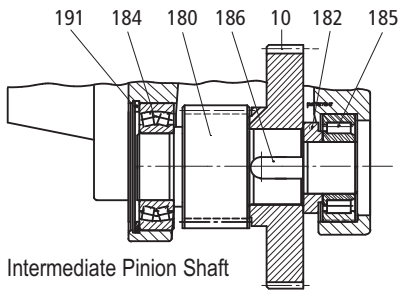

Motorized Pulley 400L, 400M & 400H, Ø 400 mm

Sectional drawings

400M - 400H Electromagnetic Brake & Backstop Option

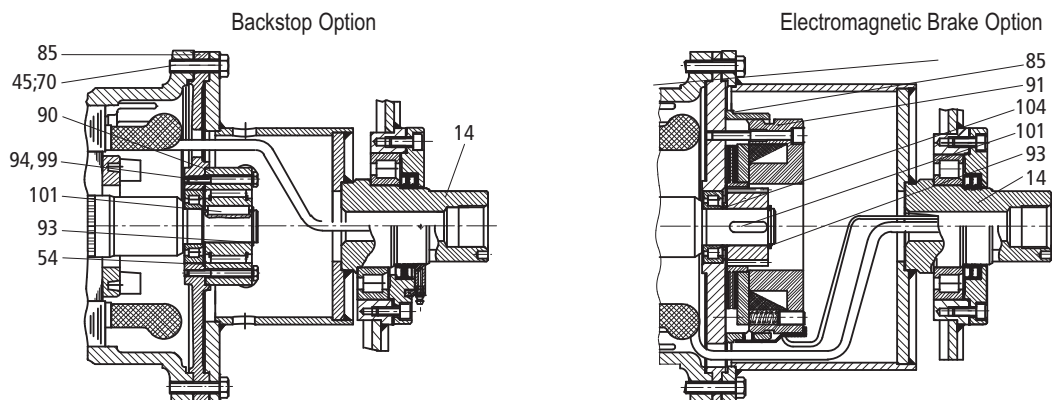

400M - 400H Labyrinth Option

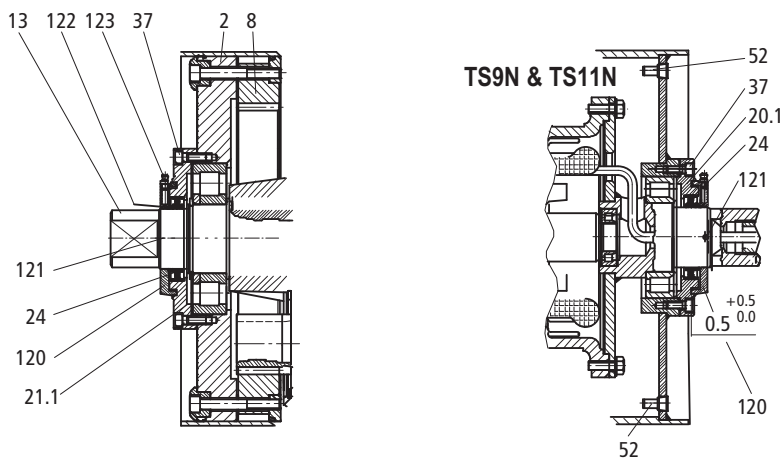

400M - 400H Stainless steel Option without Labyrinth

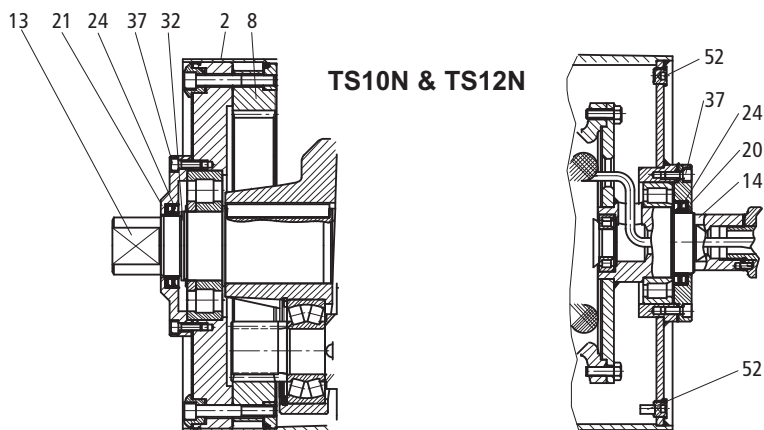



Abrasive sand, stone and gravel distribution. Motorized Pulley features: Reliable, compact, NO maintenance, IP66/67 seals



Sand, stone & gravel application featuring reliability day in and day out working 24 hours per day - 365 days per year.



Motorized Pulley 500L, 500M & 500H, Ø 500 mm

To match your requirements in diameter 500 mm, our product range offers three different loading performances for your **BULK** applications:

- **L** for Light-duty
- **M** for Medium-duty
- **H** for Heavy-duty

You have a choice.

Therefore, it is important to notice the differences to choose the right type of pulley for the right application based on estimated belt tension (radial load) = T1+T2. The actual radial load **MUST** be **LESS** than the max. allowable radial load shown in this catalogue.

Be aware of increased belt tensions using multi-ply thick heavy belts and/or larger belt widths.

If you do not find the belt tension needed in this diameter, you might have to choose a larger one.

L for Light-duty

500L is meant for similar applications as 400M *except* for the fact that the belt requires a larger pulley diameter. (Motor/gearbox origin from 400M).

500L are typically used in grain storage, cement, steel, fertilizer and heavy mobile crushing & screening applications.

As to outer dimensions, 500L cannot replace 500H (Former TM500/TM501).

M for Medium-duty

Using a solid and robust 3-stage gearbox, 500M provides the necessary torque & belt pull needed for low speeds combined with high power for irregular loadings.

(Motor/gearbox origin from 400H).

As to outer dimensions, 500M cannot replace 500H (Former TM500/TM501).

H for Heavy-duty

The construction of 500H is the heaviest of this particular range with internal parts such as gearbox, Ø 65 mm shaft, matching bearings etc. are designed for tough, irregular, extreme and brutal working conditions.

STANDARD SPECIFICATION of Motorized Pulley

- Crowned mild steel Ø 500 mm steel shell painted yellow – min. layer of 60 µm
- Bolted powder coated cast iron bearing housings and covers, all painted yellow – min. layer of 60 µm
- Mild steel shafts
- Shaft sealing system - degree of protection IP66/67(EN60034-5)
- Cast iron terminal box painted yellow – min. layer of 60 µm
- 3-phase induction motors with thermal protector
- 3-phase single voltage. Most common voltages available. Please specify!
- Motor winding insulation Class F
- Dynamically balanced rotor
- Two oil plugs each fitted with a magnet to filter the oil
- Black painted brackets – KL60 for 500L and 500M available on request
- Yellow painted graphite cast iron mounting brackets – 500H only!
- Oil change recommended every 20.000 operational hours
- Minimum RL Please refer to page 53/59
- Maximum RL – Please inquire!
- Non standard RL's available
- To be used in horizontal positions ±5 degree only!
- Nitrided shaft sleeves

Please note:

- Special speeds available on request.
- Motorized Pulleys for non-horizontal positions available on request
- Parallel shell available. Diameter equal to dimension Ø A

SEMI-RUST-FREE options

TS11 – (500L & 500M)

- Painted mild steel shell – min. layer of 120 µm
- Stainless steel shafts – AISI 303-4 range
- Painted cast iron end housings – min. layer of 120 µm
- Regreasable covers with labyrinth grooves and grease nipples in stainless steel – AISI 304 range
- Zinc-plated oil plugs
- Zinc-plated exterior bolts
- Shaft sealing system – degree of protection IP66/67 (EN60034-5)
- Painted terminal box – min. thickness layer of 120 µm

TS11 – (500H)

- Painted mild steel shell – min. layer of 120 µm
- Painted cast iron end housings – min. layer of 120 µm
- Stainless steel covers with labyrinth grooves – AISI 304 range
- Zinc-plated oil plugs – each with magnet
- Zinc-plated exterior bolts
- Shaft sealing system – degree of protection P66/67 (EN60034-5)
- Painted terminal box – min. layer of 120 µm
- Nickel plated mounting brackets with labyrinth grooves

TS12

- As TS11, but without re-greasable seals.
- Covers - standard

Please note:

- FDA & USDA food grade recognized oil and grease are NOT included in TS11 & TS12, but available on request

When ordering, please specify the required voltage, electrical connection and eventual TS-number, options, brackets and idler pulleys.

- Environmental considerations: page 77-78
- Technical precautions: pages 81-92
- Optional extras: page 51 and back cover
- Connection Diagrams: page 100.



OPTIONAL EXTRAS

Motorized Pulley 500L, 500M & 500H

Specification		500L	500M & 500H
Semi-rust-free option	Re-greasable labyrinth seals!	TS11	TS11
Semi-rust-free option	Standard seals!	TS12	TS12
Dust explosion proof Motorized Pulleys - ATEX 95 - Zone 22 - for applications handling of dusty grain etc. According to European Directive 94/9/EC.		On request!	On request!
Black rubber lagging - STANDARD specifications:		o	o
- Smooth lagging - Hardness 60 ±5 Shore A		8 mm	8 mm
- Diamond lagging - Hardness 60 ±5 Shore A		8 mm	8 mm
White smooth rubber lagging (FDA). Oil, fat & grease resistant		x	x
SPECIAL lagging available on request - e.g. hot vulcanized, ceramic etc.		x	x
Electromagnetic brake		x	x
Min. RL dimensions increases by (mm)		100	100
Mechanical backstop	500L from RL750mm & 500M from RL800 mm	x	x
Insulation class F - Allowable ambient temperature: -25°C - +40°C		Std.	Std.
Insulation class H with synthetic oil		x	x
Parallel shell		x	x
Thermal protector		Std.	Std.
IP66/67 cast iron terminal box painted yellow		Std.	Std.
Shaft sealing system - degree of protection IP66/67 (EN60034-5)		Std.	Std.
3-phase single voltage (3 x 400V) or (3 x 690V), 50 Hz, with +/-10% tolerance - DIN IEC 38		Std.	Std.
Special voltages - 50 and/or 60Hz Please specify!		x	x
Dual voltage - delta/star - connection possibility!		x	x
CSA approved motors - available on request only!		x	x

x = Optional extra's

o = An option with certain limitations. Please refer to Technical precautions pages 81-92!

Std. = Fitted as standard

Motorized Pulley 500L & 500M, Ø 500 mm

Motorized Pulley
with terminal box

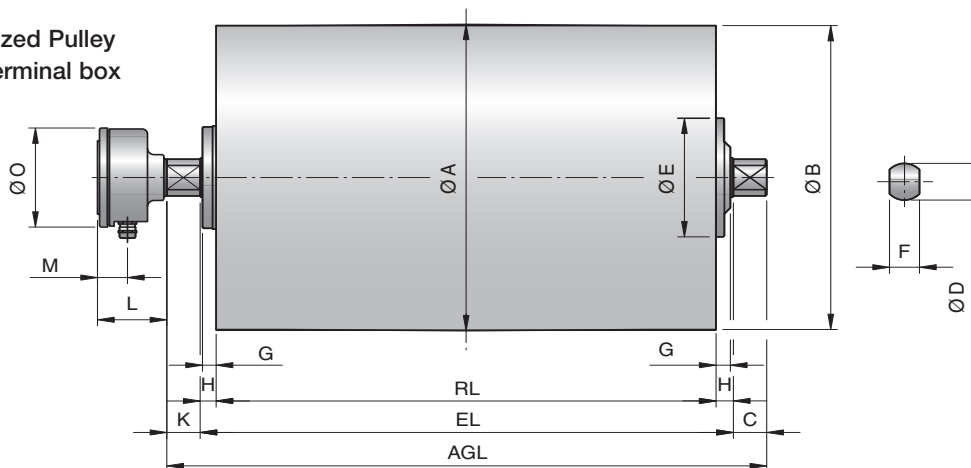

Idler Pulley
UT400M & UT400H

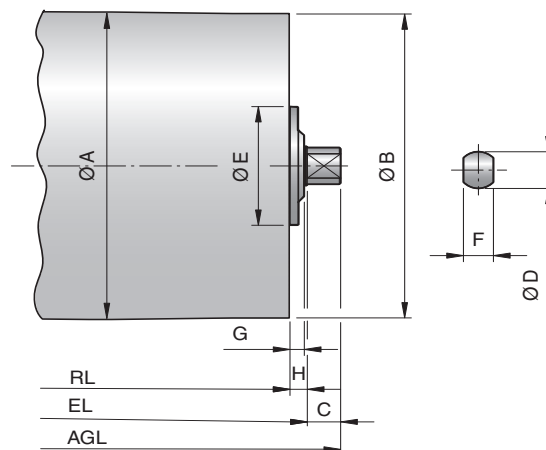

Type	Motorized Pulley or Idler Pulley (UT)										Larger terminal box			
	A mm	B mm	C mm	D mm	E mm	F mm	G mm	H mm	K mm	L mm	M mm	N mm	O mm	
500L & 500M	501	497	50	60	194	45	23	25	50	100	37	-	162	
UT400M & UT400H	404	400	50	60	168	45	20	25	-					

Mounting bracket KL60

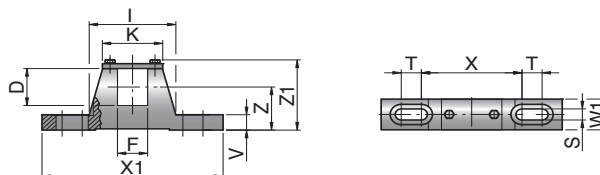

Motorized Pulleys & Idler Pulleys (UT) Type	Material	Bracket description	Dimensions												Weight kg
			D mm	F mm	I mm	K mm	S mm	T mm	V mm	W1 mm	X mm	X1 mm	Z mm	Z1 mm	
500L & 500M and UT400M & UT400H	Steel	KL60	60	45	130	90	18	30	25	50	150	270	70	115	4.8



Motorized Pulley 500L & 500M, Ø 500 mm

50 Hz

Motor			Nominal belt speed at Full Load 50Hz m/sec	Torque Nm	Belt Pull N	Max. Radial Load T1+T2 N	Special min. RL	Type	Weight in kg for STANDARD width										per 50 mm up to 2000	Type of Bracket	
Power kW/HP	No. of Poles	Gear stages							Dimension RL in mm (RL >2000 mm available on request)												
									600	650	700	750	800	850	900	950	1000				
2.20/3.00	8	3	0.20	2613	10542	42200	650	500M		258	265	272	279	286	293	300	307	7 kg	KL60		
			0.25	2090	8360																
			0.32	1633	6532																
		2	0.40	1306	5224	35000	600	500L	216	223	230	237	244	251	258	265	272				
			0.50	1045	4180																
			0.63	829	3316																
4.00/5.50	8	3	0.40	2375	9500	42200	650	500M		267	274	281	288	295	302	309	316	7kg	KL60		
			0.50	1900	7600																
			0.63	1508	6032																
		2	0.80	1188	4752	35000	600	500L	225	232	239	246	253	260	267	274	281				
			1.00	950	3800																
			1.25	760	3040																
		5.50/7.50	4	3	0.50	2612	10448	42200	650	500M		258	265	272	279	286	293	300	307	7 kg	KL60
					0.63	2073	8292														
					0.80	1632	6528														
				2	1.00	1306	5214	35000	600	500L	216	223	230	237	244	251	258	265	272		
					1.25	1045	4180														
					1.60	816	3264														
7.50/10.00	6			3	0.63	2827	11308	42200	710	500M				278	285	292	299	306	313	7 kg	KL60
					0.80	2226	8904														
					1.00	1781	7124														
				4	1.25	1425	5700	35000	600	500L	222	229	236	243	250	257	264	271	278		
					1.60	1113	4452														
					2.00	891	3564														
	11.00/15.00	4	3	1.00	2612	10448	42200	710	500M				290	297	304	311	318	325	7 kg	KL60	
				1.25	2090	8630															
				1.60	1633	6532															
			2	2.00	1306	5224	35000	660	500L				255	262	269	276	283	290			
				2.50	1045	4180															
				3.15	829	3316															
15.00/20.00		2	3	1.25	2850	11400	42200	710	500M				290	297	304	311	318	325	7 kg	KL60	
				1.60	2227	8908															
				2.00	1782	7128															
		2	2.50	1425	5700	35000	660	500L				255	262	269	276	283	290				
			3.15	1131	4524																

Idler Pulley	40500	600	UT400M	113	119	126	132	138	142	148	154	160	7 kg	KL60
		50000	650	UT400H		124	131	137	143	147	153	159	165	7 kg

Motorized Pulley 500L, Ø 500 mm

Spare parts list and sectional drawings

Pos.	Description	Pos.	Description	Pos.	Description
1	Shell	27	Bearing	75	Gasket
2	End housing with geared rim	28	Bearing	76	Gasket
8	Geared rim	29	Bearing	77	Gasket
9	Rotor pinion	30	Bearing	78	Gasket
10	Input wheel	31	Bearing	85	Intermediate flange
11	Output pinion	32	Retaining ring	90	Backstop
12	Gear box – cast aluminium	36	Hexagon socket screw	91	Electromagnetic brake
13	Rear shaft	37	Hexagon socket screw	93	Retaining ring
14	Front shaft	38	Hexagon socket screw	94	Hexagon head screw
15	Stator complete	43	Hexagon socket screw	99	Waved spring washer
15.1	Rotor	44	Hexagon socket screw	101	Key
16	Terminal box complete	45	Hexagon screw	104	Distance washer
17	Nipple	50	Waved washer	120	Labyrinth cover
20	Cover – gear side	51	Gasket	121	Fixing bolt
20.1	Cover with labyrinth groove	52	Magnetic oil plug	122	O-ring
21	Cover – front side	53	Distance washer	123	Grease nipple
21.1	Cover with labyrinth groove	66	Waved washer	202	Motor data plate
24	2 Dust lip seals each side	70	Toothed washer		
26	Bearing	73	Set screw		

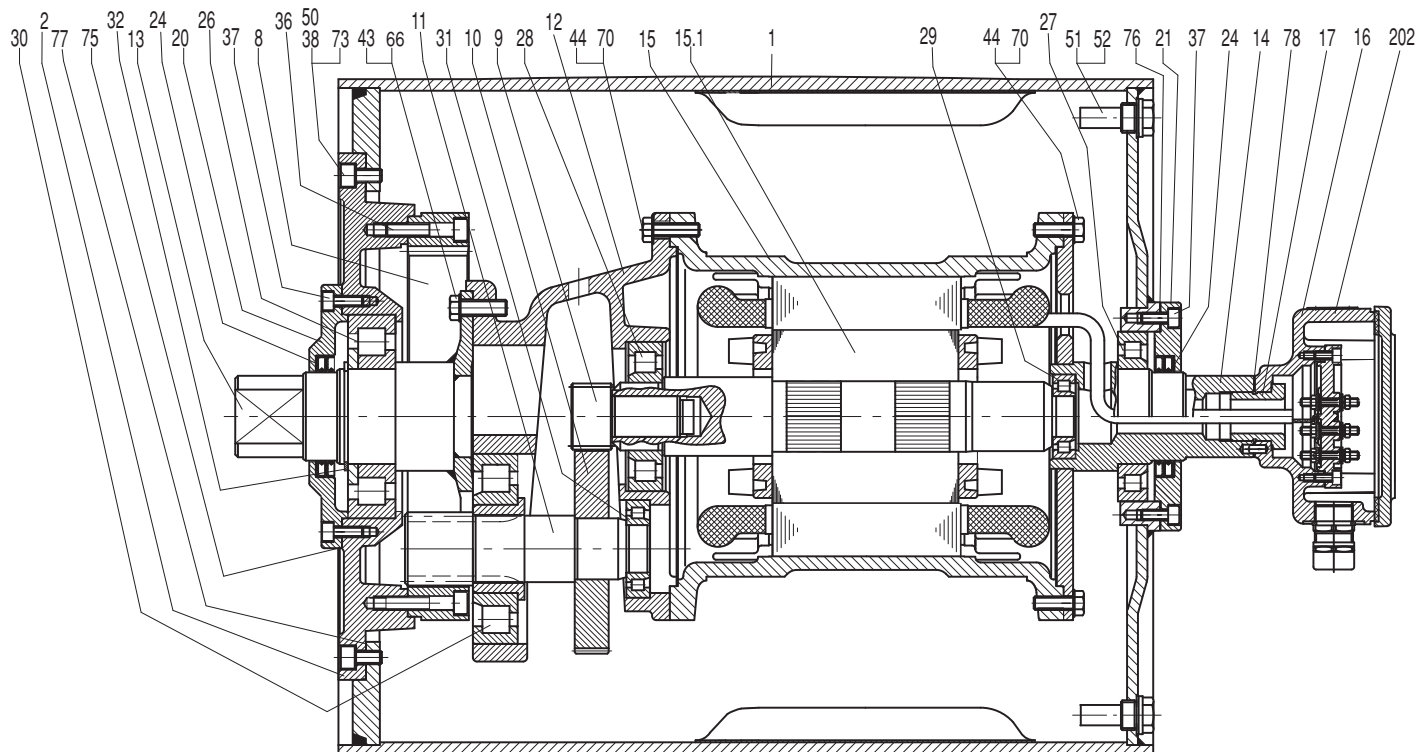

Motorized Pulley 500M, Ø 500 mm

Spare parts list and sectional drawings

Pos.	Description	Pos.	Description	Pos.	Description
1	Shell	29	Bearing	91	Electromagnetic brake
2	End housing with geared rim	30	Bearing	93	Retaining ring
3	End housing	31	Bearing	94	Hexagon head screw
8	Geared rim	32	Retaining ring	99	Waved spring washer
9	Rotor pinion	36	Hexagon socket screw	101	Key
10	Input wheel	37	Hexagon socket screw	104	Distance washer
11	Output pinion	38	Hexagon socket screw	120	Labyrinth cover
12	Gear box – graphite cast iron	44	Hexagon socket screw	121	Fixing bolt
13	Rear shaft	50	Washer	122	O-ring
14	Front shaft	51	Gasket	123	Grease nipple
15	Stator complete	52	Magnetic oil plug	180	Intermediate pinion shaft
15.1	Rotor	53	Distance washer	181	Intermediate pinion
16	Terminal box complete	70	Toothed washer	182	Distance washer
17	Nipple	72	Toothed washer	184	Bearing
20	Cover rear side	73	Set screw	185	Bearing
20.1	Cover with labyrinth groove	75	Gasket	186	Key
21	Cover front side	76	Gasket	187	Key
21.1	Cover with labyrinth groove	77	Gasket	188	Retaining ring
24	2 Dust lip seals	78	Gasket	191	Retaining ring
26	Bearing	85	Intermediate flange for brake	196	Key
27	Bearing		+ backstop	197	Retaining ring
28	Bearing	90	Backstop	202	Motor data plate

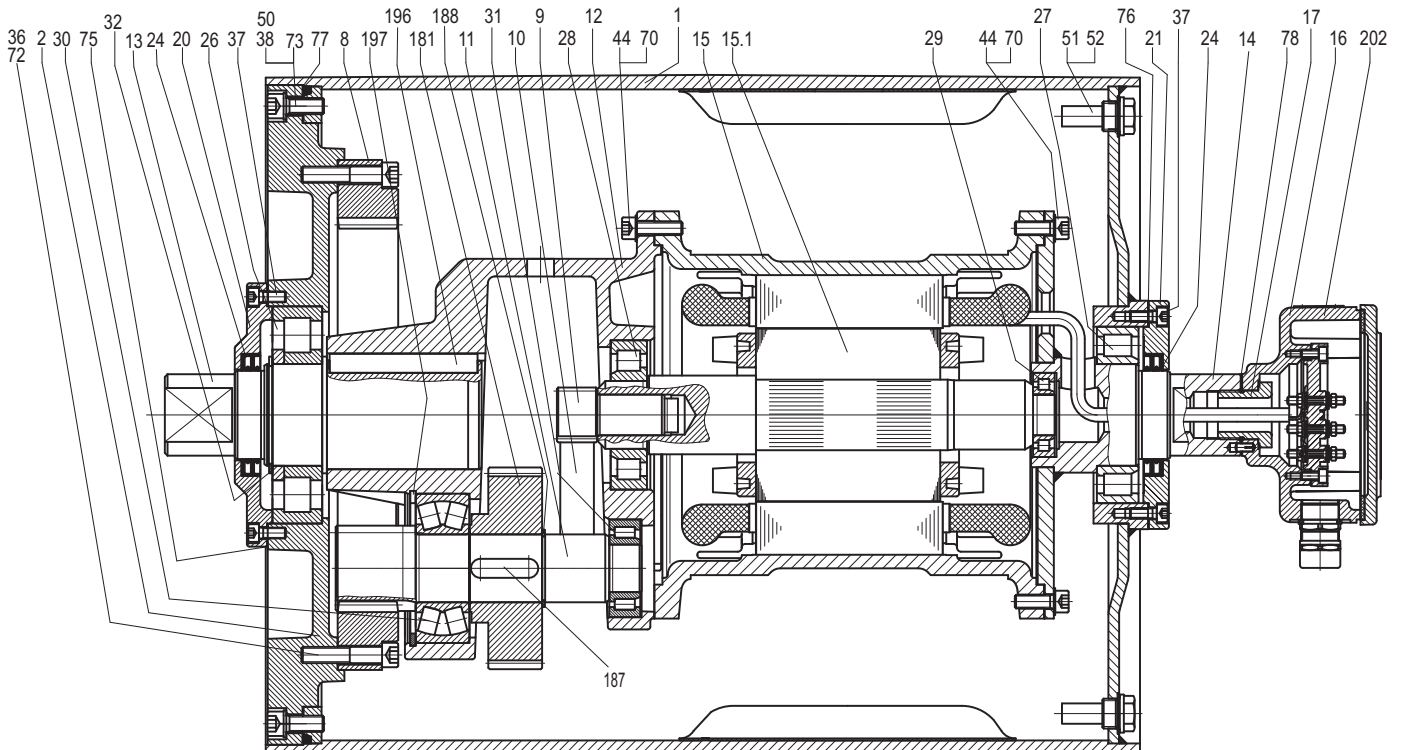

Motorized Pulley 500L & 500M, Ø 500 mm

Sectional drawings

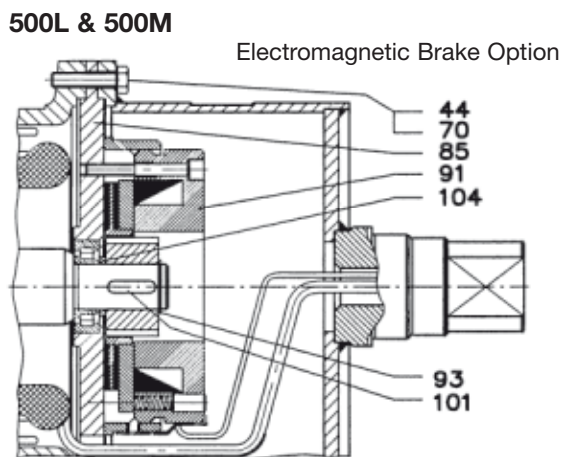
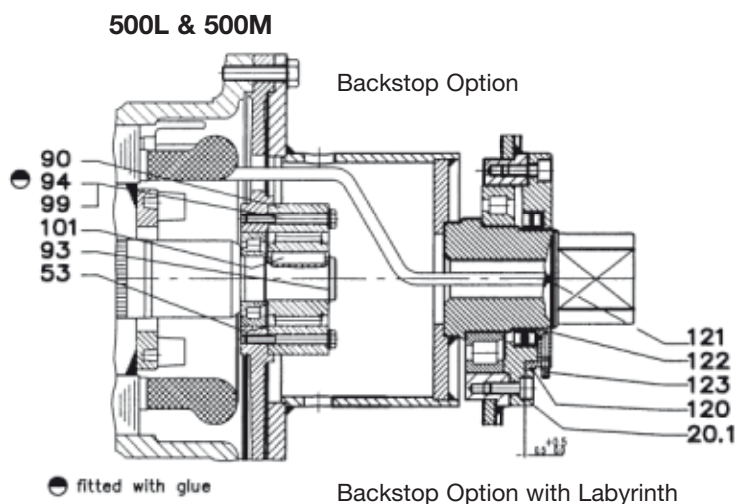
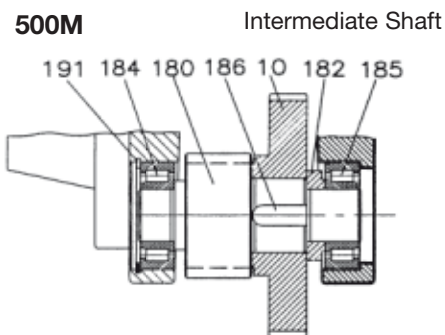



Fertilizer - 35 year old drive and still working round the clock!



Limestone application. Features: Compact, robust, reliable, NO maintenance. The right choice by experience!

Motorized Pulley 500H, Ø 500 mm

Motorized Pulley with terminal box

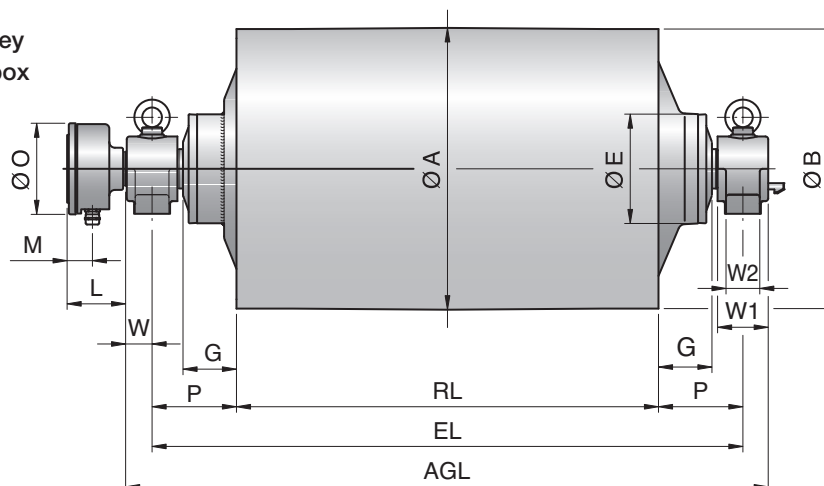

Idler Pulley UT500H

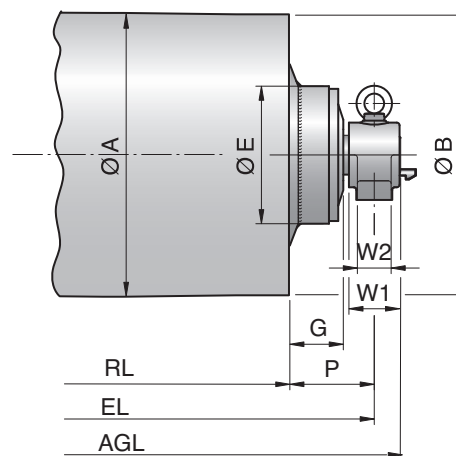

Type	A mm	B mm	C mm	D mm	E mm	G mm	L mm	M mm	O mm	P mm
500H	501	497	-	65	192	95	100	36.5	156	150
500H (30kW)	521*	417*	-	65	235	95	195	56	230	150
UT500H	501	497	-	65	235	95	-	-	-	150

* including ceramic lagging

Mounting bracket AL65 & ALO65

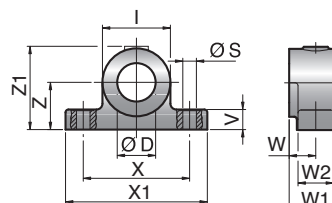

Motorized Pulleys & Idler Pulleys (UT) Type	Material	Bracket description	Dimensions												Weight kg
			D mm	I mm	S mm	V mm	W mm	W1 mm	W2 mm	X mm	X1 mm	Z mm	Z1 mm		
500H & UT500H	Spheroidal cast iron	AL65 / ALO65	65	115	23	34	45	90	60	180	240	80	141	8.0	



Motorized Pulley 500H, Ø 500 mm

50 Hz

Power kW/HP	Motor		Nominal belt speed at Full Load 50Hz m/sec	Torque Nm	Belt Pull N	Max. Radial Load T1+T2 N	Min. RL	Type	Weight in kg for STANDARD width										Type of Bracket
	No. of Poles	Gear stages							Dimension RL in mm (RL >2000 mm available on request)										
									600	650	700	750	800	850	900	950	1000	per 50 mm up to 2000	
5.50/ 7.50	8	2	0.50	2612	10427	46000	750	500H	600	650	700	750	800	850	900	950	1000	8 kg	AL65 / ALO65
			0.63	2073	8276														
			0.80	1632	6515														
	6	2	1.00	1306	5214														
			1.25	1045	4172														
			1.60	816	3258														
7.50/ 10.00	8	2	2.00	653	2607														
			2.50	522	2084														
			0.63	2827	11285														
	6	2	0.80	2226	8887														
			1.00	1780	7106														
			1.25	1424	5685														
11.0/ 15.0	8	2	1.60	1113	4443														
			2.00	890	3553														
			2.50	712	2843														
	6	2	1.00	2611	10423														
			1.25	2089	8340														
			1.60	1632	6515														
15.0 15.0/ 20.0	4	2	2.00	1306	5214														
			2.50	1045	4172														
			1.00	3644	14450														
	4	2	1.25	2850	11377														
			1.60	2226	8886														
			2.00	1781	7110														
18.5 18.5/ 25.0	4	2	2.50	1425	5689														
			3.15	1131	4515														
			1.25	3596	14356														
	4	2	1.60	2746	10962														
			2.00	2197	8771														
			2.50	1757	7014														
22.0/ 30.0	4	2	3.15	1395	5569														
			1.60	3444	13750														
			2.00	2611	10423														
	2	2	2.50	2089	8340														
			3.15	1600	6385														
			1.60	4236	16977														
1*) 30.0/ 40.0	4	2	2.00	3801	15236														
			2.50	3049	12222														
			3.15	2498	10012														
	4	2	4.00	1901	7618														
			1.60	4236	16977														
			2.00	3801	15236														

1*) Please note the 30kW motor will be delivered with 10mm bonded ceramic lagging!
 Note: for MP 500M & H external brake shaft is not possible!

Idler Pulley	46000	600	UT500H	600	650	700	212	220	229	237	246	255	8 kg	AL65 / ALO65
---------------------	-------	-----	--------	-----	-----	-----	-----	-----	-----	-----	-----	-----	------	-----------------

Sectional drawings: please refer to pages 68-70!



Motorized Pulley 630M & 630H, Ø 630 mm

To match your requirements in diameter 630 mm, our product range offers two different loading performances for your BULK applications:

- 630M and
- 630H

You have a choice.

Therefore, it is important to notice the differences to choose the right type of pulley for the right application based on estimated belt tension (radial load) = T1+T2. The actual radial load **MUST** be **LESS** than the max. allowable radial load shown in this catalogue.

Be aware of increased belt tensions using multi-ply thick heavy belts and/or larger belt widths.

If you do not find the belt tension needed in this diameter, you might have to choose a larger one.

Except for the fact that motor/gearbox of 630M originates from 500H, both types – 630M and 630H – are designed for HEAVY DUTY applications. They provide the necessary torque and belt pull.

Both pulleys are designed for tough, irregular, extreme and brutal working conditions.

STANDARD SPECIFICATION of Motorized Pulley

- Crowned mild steel Ø 630 mm steel shell painted yellow - min. layer of 60 µm
- Bolted powder coated cast iron bearing housings and covers, all painted yellow – min. layer of 60 µm
- Mild steel shafts
- Shaft sealing system - degree of protection IP66/67 (EN60034-5)
- Cast iron terminal box painted yellow – min. layer of 60 µm
- 3-phase induction motors with thermal protector
- Voltage: 3-phase single voltage. Most common voltages available. Please specify!
- Motor winding insulation Class F
- Dynamically balanced rotor
- Two oil plugs each fitted with a magnet to filter the oil
- Yellow painted cast steel mounting brackets – one type AL & one type ALO
- Oil change recommended every 20.000 operational hours
- Maximum RL – Please inquire!
- Non standard RL's available
- To be used in horizontal positions ±5 degree only!
- Special speeds available on request.

SEMI-RUST-FREE options

TS11

- Painted mild steel shell – min. layer of 120 µm
- Painted cast iron end housings – min. layer of 120 µm
- Stainless steel covers with labyrinth grooves – AISI 304 range
- Nitrided shaft sleeves
- Zinc-plated oil plugs – each with magnet
- Zinc-plated exterior bolts
- Shaft sealing system – degree of protection IP66/67 (EN60034-5)
- Painted terminal box – min. layer of 120 µm
- Nickel plated mounting brackets with labyrinth grooves

TS12

- As TS11, but without re-greasable seals.
- Covers - standard

Please note:

- FDA & USDA food grade recognized oil and grease are NOT included in TS11 & TS12, but available on request.

When ordering, please specify the required voltage, electrical connection and eventual TS-number, options, brackets and idler pulleys.

- Environmental considerations: page 77-78
- Technical precautions: pages 81-92
- Optional extras: page 61 and back cover
- Connection Diagrams: page 100.



OPTIONAL EXTRAS

Motorized Pulley 630M & 630H

Specification	630M	630H
Semi-rust-free option Re-greasable labyrinth seals!	TS11	TS11
Semi-rust-free option Standard seals!	TS12	TS12
Dust explosion proof Motorized Pulleys - ATEX 95 - Zone 22 - for applications handling of dusty grain etc. According to European Directive 94/9/EC.	On request!	On request!
Re-greasable labyrinth seals - mild steel	x	x
Black rubber lagging - STANDARD specifications: - Smooth lagging - Hardness 60 ±5 Shore A - Diamond lagging - Hardness 60 ±5 Shore A	o 10 mm 10 mm	o 10 mm 10 mm
White smooth rubber lagging (FDA). Oil, fat & grease resistant	x	x
SPECIAL lagging available on request - e.g. hot vulcanized, ceramic etc.	x	x
External brake shaft for connection to mechanical brake	x	x
Mechanical backstop	x	x
Insulation class F - Allowable ambient temperature: -25°C-+40°C	Std.	Std.
Insulation class H with synthetic oil	x	x
Parallel shell	x	x
Thermal protector	Std.	Std.
IP66/67 cast iron terminal box painted yellow	Std.	Std.
Shaft sealing system - degree of protection IP66/67 (EN60034-5)	Std.	Std.
3-phase single voltage (3 x 400V) or (3 x 690V), 50 Hz, with +/-10% tolerance - DIN IEC 38	Std.	Std.
Special voltages - 50 and/or 60Hz Please specify!	x	x
Dual voltage - delta/star - connection possibility!	x	x
CSA approved motors - available on request only!	x	x
Electromagnetic brake Min RL dimension increases by (mm)	100	-

x = Optional extra's

o = An option with certain limitations. Please refer to Technical precautions pages 81-92!

Std. = Fitted as standard

Motorized Pulley 630M & 630H, Ø 630 mm

Motorized Pulley
with terminal box

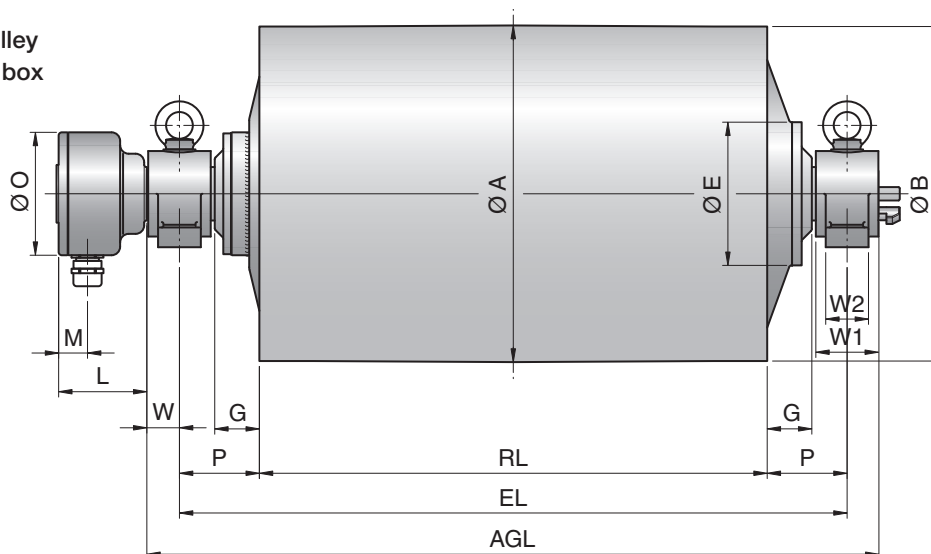

Idler Pulley
UT500H / UT502H

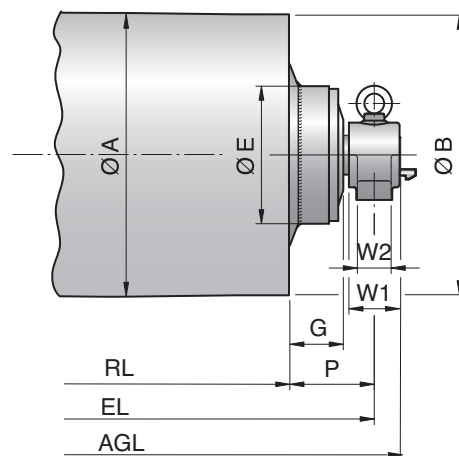

Type	A mm	B mm	C mm	D mm	E mm	G mm	L mm	M mm	O mm	P mm
630M	630	626	-	65	192	95	100	36	156	150
630H	630	626	-	90	268	84	165	56	230	150
UT500H	501	497	-	65	235	95	-	-	-	150
UT502H	501	497	-	90	226	85	-	-	-	150

Mounting brackets
AL65 & ALO65
AL90 & ALO90

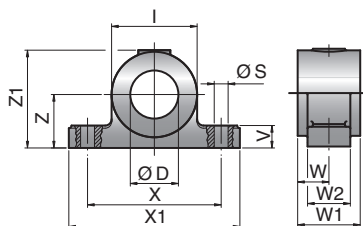

Motorized Pulleys & Idler Pulleys (UT) Type	Material	Bracket description	Dimensions											Weight kg
			D mm	I mm	S mm	V mm	W mm	W1 mm	W2 mm	X mm	X1 mm	Z mm	Z1 mm	
630M & UT500H	Spheroidal cast iron	AL65 / ALO65	65	115	23	34	45	90	60	180	240	80	141	8.0
630H & UT502H	Cast steel	AL90 / ALO90	90	160	26	42	58.5	117	80	250	320	100	183	19.0



Motorized Pulley 630M, Ø 630 mm

50 Hz

Motor		Nominal belt speed at Full Load 50Hz m/sec	Torque Nm	Belt Pull N	Max. Radial Load T1+T2 N	Min. RL	Type	Weight in kg for STANDARD width									Type of Bracket
Power kW/HP	No. of Poles							Dimension RL in mm (RL >2000 mm available on request)									
								750	800	850	900	950	1000	1050	1100	per 50 mm up to 2000	
5.50/7.50	8	0.63	2612	8292	46000	750	630M	395	404	413	422	431	441	450	459	9 kg	AL65/ALO65
		0.80	2057	6530													
		1.00	1645	5222													
	6	1.25	1316	4178													
		1.60	1028	3264													
		2.00	823	2613													
7.50/10.0	8	2.50	658	2089	46000	750	630M	404	413	422	431	440	450	459	468	9 kg	AL65/ALO65
		3.15	522	1657													
		1.00	2243	7121													
	6	1.25	1795	5699													
		1.60	1402	4451													
		2.00	1122	3562													
11.0/15.0	6	2.50	897	2848	46000	750	630M	419	428	438	447	456	466	475	484	9 kg	AL65/ALO65
		3.15	712	2261													
		1.25	2631	8356													
		1.60	2056	6527													
		2.00	1645	5222													
		2.50	1316	4178													
15.0/20.0	4	3.15	1045	3318	46000	750	630M	430	439	449	458	467	477	486	495	9 kg	AL65/ALO65
		2.00	2243	7121													
		2.50	1795	5699													
		3.15	1424	4521													
		2.00	2767	8784													
		2.50	2213	7026													
18.5/25.0	4	3.15	1757	5578	46000	750	630M	440	449	459	468	477	487	496	505	9 kg	AL65/ALO65
		2.00	3222	10450													
		2.50	2634	8362													
		3.15	2090	6635													
		2.50	2634	8362													
		3.15	2090	6635													

Idler Pulley	46000	750	UT500H	212	220	229	237	246	255	263	271	8 kg	AL65/ALO65
---------------------	-------	-----	--------	-----	-----	-----	-----	-----	-----	-----	-----	------	------------

Motorized Pulley 630H, Ø 630 mm

50 Hz

Motor		Nominal belt speed at Full Load 50Hz m/sec	Torque Nm	Belt Pull N	Max. Radial Load T1+T2 N	min. RL	Type	Weight in kg for STANDARD width									Type of Bracket															
Power kW/HP	No. of Poles							Dimension RL in mm (RL >2000 mm available on request)																								
								950	1000	1050	1100	1150	1200	1250	1300	per 50 mm up to 2000																
22.0/30.0	8	1.00	6583	20899	73600	950	630H	805	818	830	843	855	865	878	891	13 kg	AL90/ALO90															
		1.25	5265	16714																												
		1.60	4113	13057																												
		2.00	3290	10445																												
		2.50	2632	8356																												
		3.15	2089	6632																												
30.0/40.0	8	1.25	7179	22791	98100	950	630H	825	838	850	863	875	885	898	911	13 kg	AL90/ALO90															
		1.60	5609	17807																												
		2.00	4487	14245																												
		2.50	3589	11394																												
		3.15	2849	9045																												
		37.0/50.0	6	1.60														6920	21969	98100	950	630H	825	838	850	863	875	885	898	911	13 kg	AL90/ALO90
2.00	5534			17569																												
2.50	4427			14054																												
3.15	3513			11153																												
45.0/61.0	4			2.50	5384	17092	88300	950	630H	845	858	870	883	895	905	918	931	13 kg	AL90/ALO90													
				3.15	4273	13565																										
		4.00	3365	10683																												
		55.0/75.0	4	2.50	6584	20902														88300	950	630H	845	858	870	883	895	905	918	931	13 kg	AL90/ALO90
				3.15	5223	16581																										
				4.00	4113	13057																										

Idler Pulley	98100	750	UT502H	287	296	305	314	322	331	340	349	9 kg	AL90/ALO90
---------------------	-------	-----	--------	-----	-----	-----	-----	-----	-----	-----	-----	------	------------

Sectional drawings: please refer to pages 68-70!

Note: for MP 630M & H electromagnetic brake is not possible



Motorized Pulley 800M, H & 800HD, Ø 800 mm

To match your requirements in diameter 800 mm, our product range offers two different loading performances for your BULK applications:

- 800M, 800H
- 800HD

You have a choice.

Therefore, it is important to notice the differences to choose the right type of pulley for the right application based on estimated belt tension (radial load) = T1+T2. The actual radial load **MUST** be **LESS** than the max. allowable radial load shown in this catalogue.

Be aware of increased belt tensions using multi-ply thick heavy belts and/or larger belt widths.

Motor/gearbox of 800M has its origin from 630H.

However, 800H remains top of the range as to design, reinforcement and strength.

800M, H & 800HD are designed for HEAVY DUTY applications and they provide the necessary torque, belt pull and allowable belt tension in order to handle the toughest, irregular & most extreme and brutal working conditions.

STANDARD SPECIFICATION of Motorized Pulley

- Crowned mild steel Ø 800 mm steel shell painted yellow - min. layer of 60 µm
- Bolted powder coated cast iron bearing housings and covers, all painted yellow – min. layer of 60 µm
- Mild steel shafts
- Shaft sealing system - degree of protection IP66/67 (EN60034-5)
- Cast iron terminal box painted yellow – min. layer of 60 µm
- 3-phase induction motors with thermal protector
- Voltage: 3-phase single voltage. Most common voltages available. Please specify!
- Motor winding insulation Class F
- Dynamically balanced rotor
- Two oil plugs each fitted with a magnet to filter the oil
- Yellow painted cast steel mounting brackets – one type AL & one type ALO
- Oil change recommended every 20.000 operational hours
- Maximum RL – Please inquire!
- Non standard RL's available
- To be used in horizontal positions ±5 degree only!
- Special speeds available on request.

SEMI-RUST-FREE options

TS11

- Painted mild steel shell – min. layer of 120 µm
- Painted cast iron end housings – min. layer of 120 µm
- Stainless steel covers with labyrinth grooves – AISI 304 range
- Nitrided shaft sleeves
- Zinc-plated oil plugs – each with magnet
- Zinc-plated exterior bolts
- Shaft sealing system – degree of protection IP66/67 (EN60034-5)
- Painted terminal box – min. layer of 120 µm
- Nickel plated mounting brackets with labyrinth grooves

TS12

- As TS11, but without re-greasable seals.
- Covers - standard

Please note:

- FDA & USDA food grade recognized oil and grease are NOT included in TS11 & TS12, but available on request.

When ordering, please specify the required voltage, electrical connection and eventual TS-number, options, brackets and idler pulleys.

- Environmental considerations: page 77-78
- Technical precautions: pages 81-92
- Optional extras: page 65 and back cover
- Connection Diagrams: page 100.



OPTIONAL EXTRAS

Motorized Pulley 800M, H & 800HD

Specification	800M	800H/HD
Semi-rust-free option Re-greasable labyrinth seals!	TS11	TS11
Semi-rust-free option Standard seals!	TS12	TS12
Dust explosion proof Motorized Pulleys - ATEX 95 - Zone 22 - for applications handling of dusty grain etc. According to European Directive 94/9/EC.	On request!	On request!
Re-greasable labyrinth seals - mild steel	x	x
Black rubber lagging - STANDARD specifications: - Smooth lagging - Hardness 60 ±5 Shore A - Diamond lagging - Hardness 60 ±5 Shore A	o 10 mm 10 mm	o 10 mm 10 mm
White smooth rubber lagging (FDA). Oil, fat & grease resistant	x	x
SPECIAL lagging available on request - e.g. hot vulcanized, ceramic etc.	x	x
External brake shaft for connection to mechanical brake	x	x
Mechanical backstop	x	x
Insulation class F - Allowable ambient temperature: -25°C-+40°C	Std.	Std.
Insulation class H with synthetic oil	x	x
Parallel shell	x	x
Thermal protector	Std.	Std.
IP66/67 cast iron terminal box painted yellow	Std.	Std.
Shaft sealing system - degree of protection IP66/67 (EN60034-5)	Std.	Std.
3-phase single voltage (3 x 400 V) or (3 x 690V), 50 Hz, with +/-10% tolerance - DIN IEC 38	Std.	Std.
Special voltages - 50 and/or 60Hz Please specify!	x	x
Dual voltage - delta/star - connection possibility!	x	x
CSA approved motors - available on request only!	x	x

x = Optional extra's

o = An option with certain limitations. Please refer to Technical precautions pages 81-92!

Std. = Fitted as standard

Motorized Pulley 800M, H & 800HD, Ø 800 mm

Motorized Pulley
with terminal box

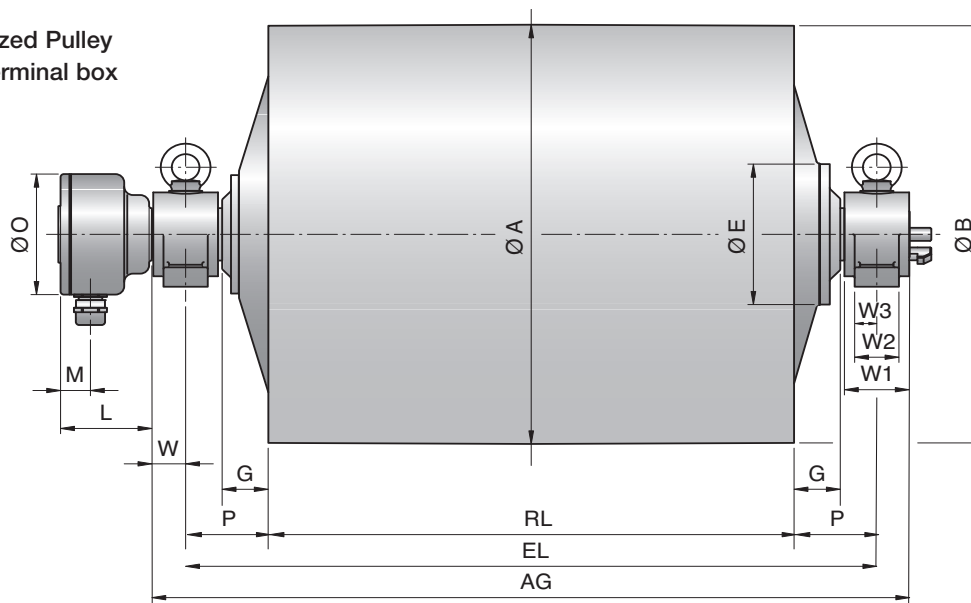

Idler Pulley
UT630M / UT630H

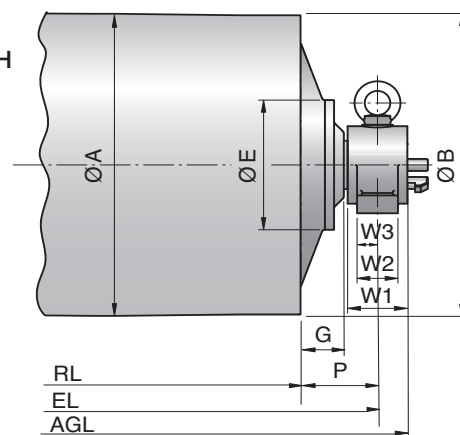

Type	A mm	B mm	C mm	D mm	E mm	G mm	L mm	M mm	O mm	P mm
800M	800	796	-	90	268	88	165	54	230	150
800H/HD	800	796	-	120	330	80	200	62	260	150
UT630M	630	626	-	90	226	85	-	-	-	150
UT630H	630	626	-	120	330	75	-	-	-	150

Mounting brackets
AL90 & ALO90
AL120 & ALO120
AL121 & ALO121

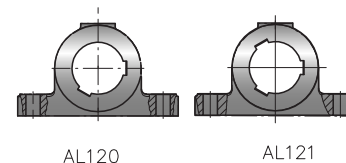
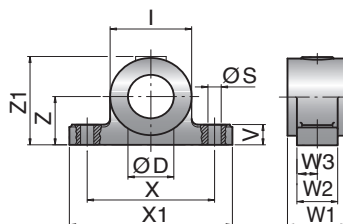

Motorized Pulleys & Idler Pulleys (UT) Type	Material	Bracket description	Dimensions											Weight kg	
			D mm	I mm	S mm	V mm	W mm	W1 mm	W2 mm	W3 mm	X mm	X1 mm	Z mm		Z1 mm
800M & UT630M	Cast steel	AL90/ALO90	90	160	26	42	58.5	117	80	58.5	250	320	100	183	19.0
800H & UT630H	Cast steel	AL120/ALO120	120	200	33	50	95	160	120	65.0	300	370	110	213	38.0



Motorized Pulley 800M, Ø 800 mm

50 Hz

Motor Power kW/HP	No. of Poles	Gear stage	Nominal belt speed at Full Load 50Hz m/sec	Torque Nm	Belt Pull N	Max. Radial Load T1+T2 N	Min. RL	Type	Weight in kg for STANDARD width								Type of Bracket
									Dimension RL in mm (RL >2000 mm available on request)								
									950	1000	1050	1100	1150	1200	1250	per 50 mm up to 2000	
22.0/30.0	8	2	1.25	6688	16720	73600	950	800M	935	948	960	973	985	995	1005	13 kg	AL90/ALO90
			1.60	5223	13058												
			2.00	4178	10445												
			2.50	3343	8358												
			3.15	2653	6633												
30.0/40.0	8	2	1.60	7122	17805	98100	950	800M	975	988	1000	1013	1025	1035	1045	13 kg	AL90/ALO90
			2.00	5698	14245												
			2.50	4558	11395												
			3.15	3617	9043												
37.0/50.0	6	2	2.00	7030	17575	98100	950	800M	975	988	1000	1013	1025	1035	1045	13 kg	AL90/ALO90
			2.50	5622	14055												
			3.15	4462	11155												
			4.00	3513	8783												
45.0/61.0	4	2	3.15	5426	13565	88300	950	800M	995	1008	1020	1033	1045	1055	1065	13 kg	AL90/ALO90
			4.00	4273	10683												
55.0/75.0	4	2	3.15	6584	14581	88300	950	800M	995	1008	1020	1033	1045	1055	1065	13 kg	AL90/ALO90
			4.00	5223	13058												
Idler Pulley						98100	750	UT630M	327	336	345	354	362	371	380	9 kg	AL90/ALO90

Motorized Pulley 800H/HD, Ø 800 mm

50 Hz

Motor Power kW/HP	No. of Poles	Gear stage	Nominal belt speed at Full Load m/sec	Torque Nm	Belt Pull N	Max. Radial Load T1+T2 N	Min. RL	Type	Weight in kg for STANDARD width								Type of Bracket	
									Dimension RL in mm (RL >2000 mm available on request)									
									1400	1450	1500	1550	1600	1650	1700	per 50 mm up to 2000		
55.0/ 75.0	8	3	1.00	20884	54974	200000	1300	800HD	2390	2420	2450	2455	2485	2515	2546	30kg	AL121/ALO121	
			1.25	16707	41300													
	6	2	2	1.60	13052	32630	200000	1150	800H	2150	2175	2200	2225	2250	2275	2300	25 kg	AL120/ALO120
				2.00	10450	26125												
				2.50	8360	20900												
				3.15	6635	16588												
75.0/ 100.0	6	3	1.25	22527	56318	200000	1300	800HD	2390	2420	2450	2455	2485	2515	2546	30kg	AL121/ALO121	
			1.60	18496	46240													
	2	2	2	2.00	14244	35610	200000	1150	800H	2150	2175	2200	2225	2250	2275	2300	25 kg	AL120/ALO120
				2.50	11395	28488												
				3.15	9044	22610												
				4.00	7122	17805												
90.0/ 120.0	6	3	1.60	21181	52953	200000	1550	800HD				2575	2530	2560	2590	30kg	AL121/ALO121	
			2.00	18496	46240													
	2	2	2	2.50	13674	34185	200000	1400	800H	2200	2225	2250	2275	2300	2325	2350	25 kg	AL120/ALO120
				3.15	10852	27130												
				4.00	8546	21365												
				4.50	7597	18993												
110.0/ 150.0	4	3	2.00	21915	54789	180000	1550	800HD				2575	2605	2635	2665	30kg	AL121/ALO121	
			2.50	17994	44984													
	2	2	2	3.15	13264	33160	180000	1400	800H	2175	2200	2225	2250	2275	2300	2325	25 kg	AL120/ALO120
				4.00	10445	26113												
				4.50	9265	23163												
132.0/ 180.0	4	3	2.50	21592	53981	180000	1550	800HD				2615	2645	2675	2705	30kg	AL121/ALO121	
			3.15	15153	37882													
			4.00	12535	31338													
Idler Pulley						200000	1150	UT630H	700	715	730	745	760	775	790	15 kg	AL120/ALO120	

Sectional drawings: please refer to pages 68-70!

Motorized Pulley 500H – 800H, Ø 500 mm – 800 mm

Spare parts list and sectional drawings

Pos.	Description	Pos.	Description	Pos.	Description
1	Shell	26	Bearing	77	Gasket
4	End housing with geared rim	27	Bearing	78	Gasket
6	Distance washer (630H/800H)	30	Bearing	79	Holding plate
8	Geared rim	31	Bearing	85	Motor flange for backstop/brake
9	Rotor pinion	32	Retaining ring	90	Backstop
10	Input wheel	33	Retaining ring	90.1	Backstop housing
11	Output pinion	34	Retaining ring	90.2	Backstop cover
12	Gear box including rear shaft	35	Retaining ring	93	Retaining ring
13	Rear shaft	37	Hexagon socket screw	94	Hexagon head screw
14	Front shaft	38	Hexagon socket screw	99	Spring washer
15	Stator complete	42	Hexagon head screw	101	Key
15.1	Rotor	44	Hexagon head screw	123	Grease nipple
16	Terminal box complete	45	Hexagon head screw	130	Brake shaft
17	Nipple (for 500H/630M only)	47	Hexagon head screw	131	Mounting bracket bearing cover
18	Mounting brackets rear side (AL)	50	Washer	132	Roller bearing
18.1	Mounting bracket with labyrinth – rear side	51	Gasket	133	Brake shaft seal
19	Mounting bracket front side (ALO)	52	Magnetic oil plug	134	Brake shaft seal
19.1	Mounting brackets with labyrinth – front side	57/58	Spring washer	135	Retaining ring
20	Cover – rear side	68	Key	136	Bolts - bearing cover
20.1	Cover with labyrinth groove	69	Gib key	137	Spring lock washer
21	Cover – front side	70	Waved spring washer	138	Key
21.1	Cover with labyrinth groove	72	Grooved pin	139	Retaining ring
24	2 Dust lip seals each side	73	Set screw	140	Key
		75	Gasket	141	Retaining ring
		76	Gasket		

Backstop Execution

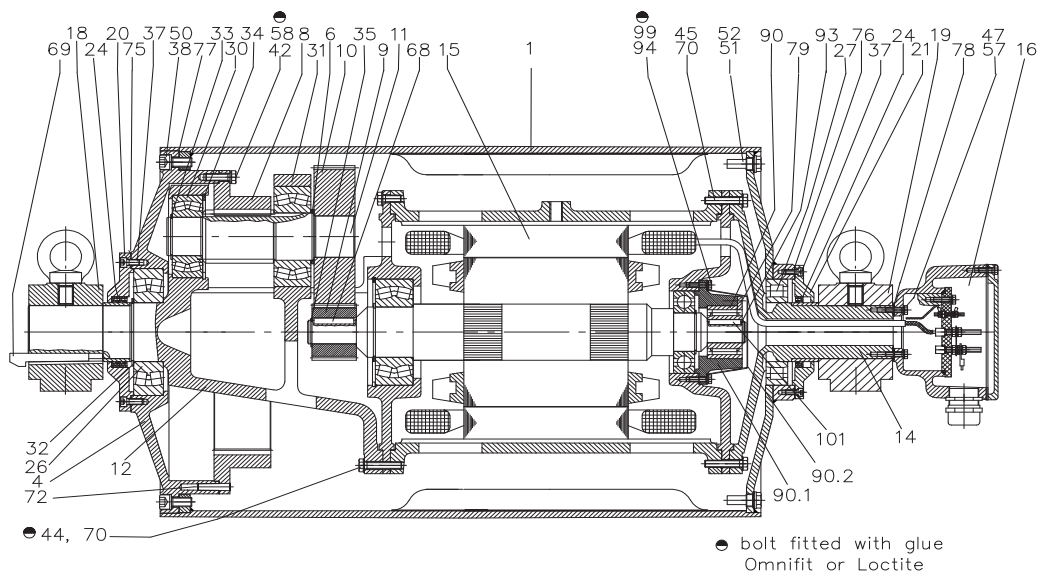

Execution with brake shaft for external brake

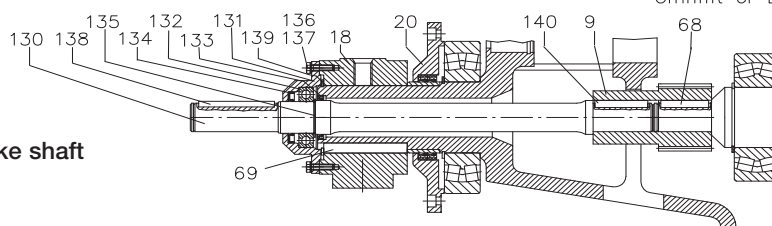

Motorized Pulley 800HD, Ø 800 mm

Spare parts list and sectional drawings

Pos.	Description	Pos.	Description	Pos.	Description
1	Shell	34	Retaining ring	130	Brake shaft
4	End housing with geared rim	35	Retaining ring	131	Mounting bracket bearing cover
6	Distance washer	37	Hexagon socket screw	132	Roller bearing
8	Geared rim	38	Hexagon socket screw	133	Brake shaft seal
9	Rotor pinion	42	Hexagon head screw	134	Brake shaft seal
10	Input wheel	44	Hexagon head screw	135	Retaining ring
11	Output pinion	45	Hexagon head screw	136	Bolts – bearing cover
12	Gear box – cast steel	47	Hexagon head screw	137	Spring lock washer
13	Rear shaft	50	Washer	138	Key
14	Front shaft	51	Gasket	139	Retaining ring
15	Stator complete	52	Magnetic oil plug	140	Key
16	Terminal box complete	58	Spring washer	188	Retaining ring
20	Cover – gear side	68	key	189	Retaining ring
20.1	Cover with labyrinth groove	69	Gib key	190	Retaining ring
21	Cover – front side	70	Waved spring washer	180	Intermediate pinion shaft
21.1	Cover with labyrinth groove	72	Grooved pin	181	Intermediate pinion
24	2 dust lip seals each side	73	Set screw	182	Distance bushing
26	Bearing	75	Gasket	183	Washer
27	Bearing	76	Gasket	184	Roller bearing
28	Bearing	77	Gasket	185	Roller bearing
30	Bearing	78	Gasket	187	Key
31	Bearing	85	motor flange for backstop	191	Retaining ring
32	Retaining ring	90	backstop complete	192	Retaining ring
33	Retaining ring	123	Grease nipple	193	Distance washer
				194	Set screw
				195	Prevailing torque type hexagon nut
				196	Key
				197	Retaining ring
				205	Retaining ring
				206	Retaining ring
				207	Retaining ring
				208	Protective ring
				209	Eye bolt
				210	Washer
				211	Cable gland
				212	Retaining ring
				220	Insulation plate

Intermediate stage

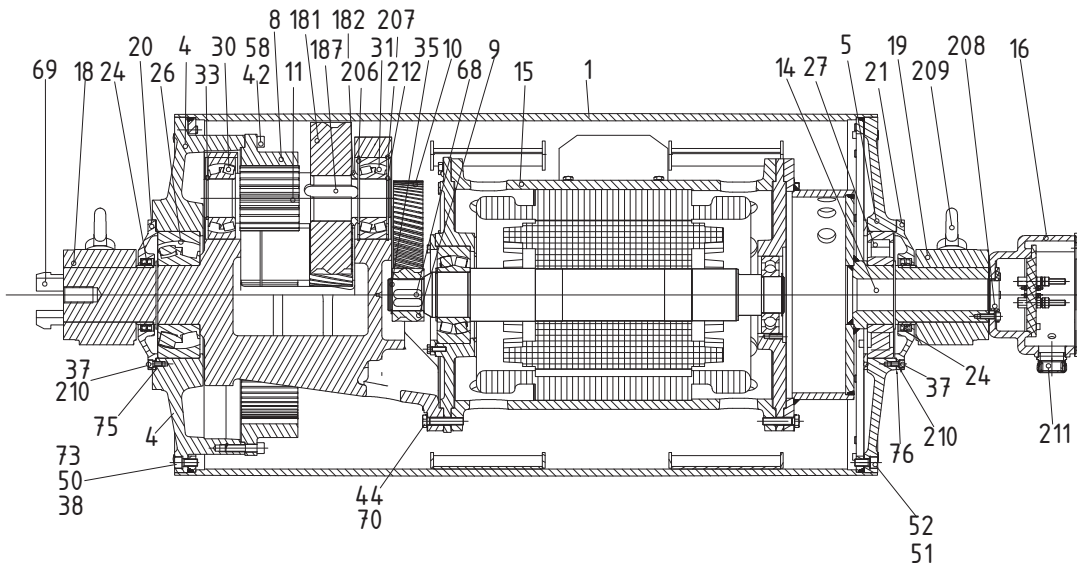
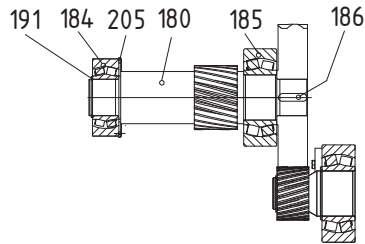

Motorized Pulley 500H - 800HD, Ø500mm - 800mm

Sectional drawings

Backstop Option

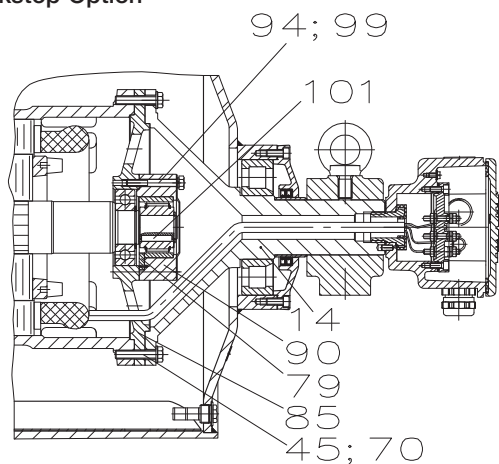

Labyrinth Option

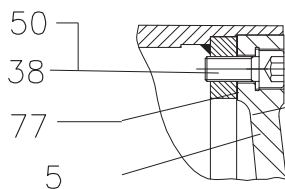
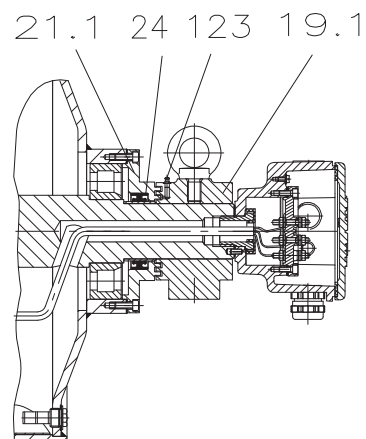

800M-1000HD bolted cast iron end housings at both sides

Terminal box execution for MP type 500H

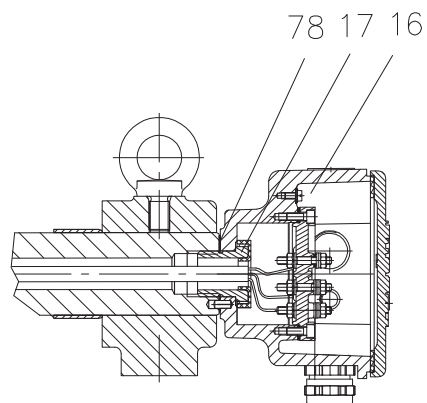

Terminal execution for MP type 630-800HD

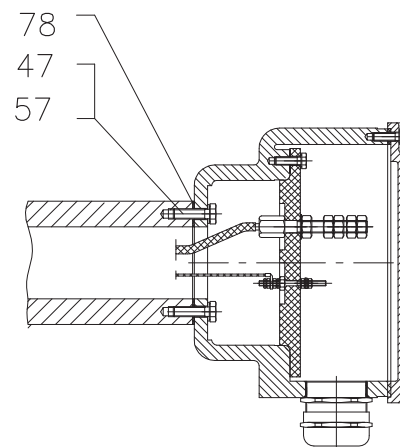

Motorized Pulley 1000HD, Ø 1000 mm

The RULMECA motorized pulley type 1000HD is a highly developed reliable and strong drive with an outstanding power range of 160 – 250 kW. It is able to take a high radial load and robust in design. Therefore it is especially developed for use in:

- Mining conveyors,
- Excavators,
- Stackers,
- Reclaimers,
- Heavy loaded conveyors in gravel and sand

The motorized pulley 1000HD is designed for tough, irregular, extreme and brutal working condition.

The compact design allows the design engineers to save material and cost when developing the conveyor.

A high protection rate connected with the standard labyrinth sealing system it can be used in all ambient conditions.

STANDARD SPECIFICATION of the Motorized Pulley

- Crowned mild steel shell + ceramic lagging, outside diameter 1020mm.
- Mild steel shafts.
- Totally enclosed cast iron brackets,
- Shell lagged with a 10mm bonded ceramic lagging,
- Bearing houses from cast steel.
- Gear 3-stage boxes from cast steel.
- Sealing system with degree of protection IP66/67 (EN60034-5).
- Terminal box from cast iron.
- 3-phase induction motors with 3 phase single voltage,
- Std. voltages 400V, 415V, 525V, 690V, 50Hz & 460V, 575V 60Hz

Please specify!

- Motor winding insulations class H,
- 3 bimetallic thermal protectors in connected series, 2 temperature resistors Pt100 and 3 PTC-resistors connected in series installed in the winding.
- Rotor dynamically balanced.
- 2 oil plugs (with magnet).

- Minimum roller length RL = 1400mm at 160kW & 1500 at 250kW,
- Synthetic oil EP220.
- First oil change recommended after 30.000 operational hours.
- Regreasable labyrinth seals with automatic greasing system,
- Special speeds available on request,

Please Note!

- Environmental conditions: page 77-78.
- Technical precautions page 81-92,
- Optional extras on page 72,
- Connection diagrams on page 100.





OPTIONAL EXTRAS

Motorized Pulley 1000HD

Option	1000HD
Different types and shapes of ceramic lagging	x
Mechanical backstop RL + 0	x
External brake shaft RL + 0	x
Allowable ambient temperatures	-25°C until +40°C
Insulation class H with synthetic oil	Std.
Motor protection and Control by 3 bimetallic thermal protectors connected in series, 2 temperature resistors PT100 and 3 PTC-resistors connected in series	Std.
Dust Explosion proof Motorized Pulleys – ATEX95 – Zone 22 – for applications handling of dusty grain etc. according to European Directive 94/9/EC	x
Thermal winding protection	Std.
IP66/67 cast iron terminal box	Std.
Degree of protection IP66/67	Std.
Triphase single voltage (3x400V, 415V, 525V & 690V at 50Hz & 460V, 575V 60Hz) with tolerances +/-10% (DIN IEC 38)	Std.
Other voltages up to 1000V	x
CSA approved motors	x

Std. = standard

x = available as option

Motorized Pulley 1000 HD, Ø 1000 mm

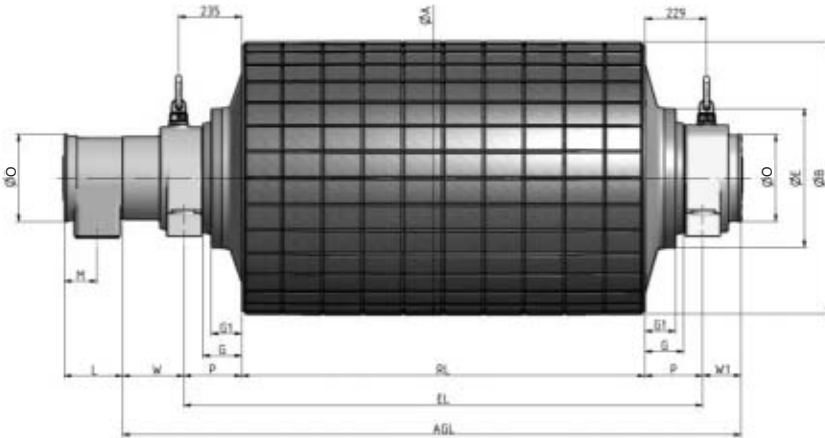

Motorized Pulley Dimension

A	B	D	E	G	G1	L	M	O	P	W	W1	W4
mm	mm	mm	mm	mm	mm	mm	mm	mm	mm	mm	mm	mm
1020	1014	203	520	145	114	218	122	325	215	228	143	150

ALO

AL

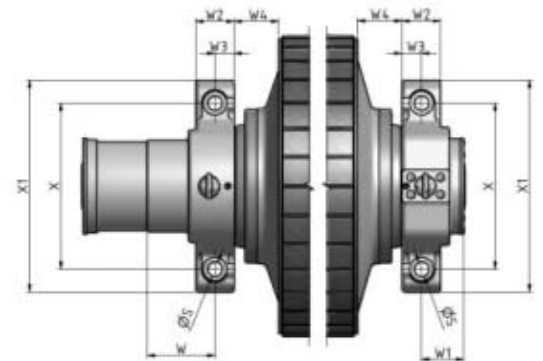

Standard External Brake Shaft Dimension

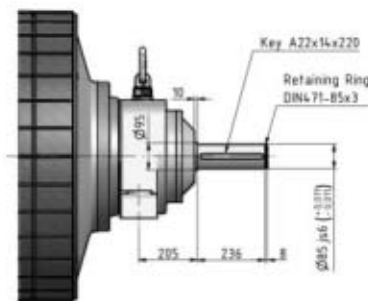

Bracket Dimension

Type	S	W2	W3	X	X1	Z	Z1
	mm	mm	mm	mm	mm	mm	mm
AL	50	130	65	560	717	215	412
ALO	50	130	65	560	717	215	412

Motorized Pulley 1000HD Ø 1000 mm

50 Hz

Motor		Nominal belt speed at Full Load 50Hz m/sec	Torque		Belt Pull N	Max. Load T1+T2 N	min. RL	Type	Weight in kg for STANDARD width										Type of Bracket
Power kW/HP	No. of Poles		RL in mm								per 50 mm up to 2500								
			1400	1450					1500	1550		1600	1650	1700	1750	1800			
160.0/ 218.0	4	2.50	30300	59400	300000	1400	1000HD	4200	4270	4315	4380	4445	4510	4575	4640	4705	65 kg	AL200/ ALO200	
		3.15	24400	47800				4270	4315	4380	4445	4510	4575	4640	4705				
		4.00	19200	37600				4315	4380	4445	4510	4575	4640	4705	4705				
		4.50	16700	32700				4380	4445	4510	4575	4640	4705	4705	4705				
		5.50	14000	27400				4445	4510	4575	4640	4705	4705	4705	4705				
200.0/ 272.0	4	2.50*	37900	74300	300000	1450	1000HD	4200	4450	4520	4565	4630	4695	4760	4825	4890	65 kg	AL200/ ALO200	
		3.15*	30600	60000				4450	4520	4565	4630	4695	4760	4825	4890				
		4.00	24000	47000				4520	4565	4630	4695	4760	4825	4890	4890				
		4.50	20900	40950				4565	4630	4695	4760	4825	4890	4890	4890				
		5.50	17600	34500				4630	4695	4760	4825	4890	4890	4890	4890				
250.0/ 340.0	4	2.50*	47400	92900	300000	1500	1000HD	4200	4270	4700	4770	4815	4880	4945	5010	5075	65 kg	AL200/ ALO200	
		3.15*	38200	74900				4700	4770	4815	4880	4945	5010	5075					
		4.00	30000	58800				4770	4815	4880	4945	5010	5075	5075					
		4.50	26150	51250				4815	4880	4945	5010	5075	5075	5075					
		5.50	22000	43100				4880	4945	5010	5075	5075	5075	5075					

* Power and speeds marked with a star can be used with 100% load at clockwise direction of rotation only! For anti-clockwise direction the motorized pulley has to be assembled in an opposite way.
 Note: Please specify the outer diameter of your connection cable.
 Because of high torque the start-up of the motorized pulley has to be done with a soft starter or a variable frequency drive.

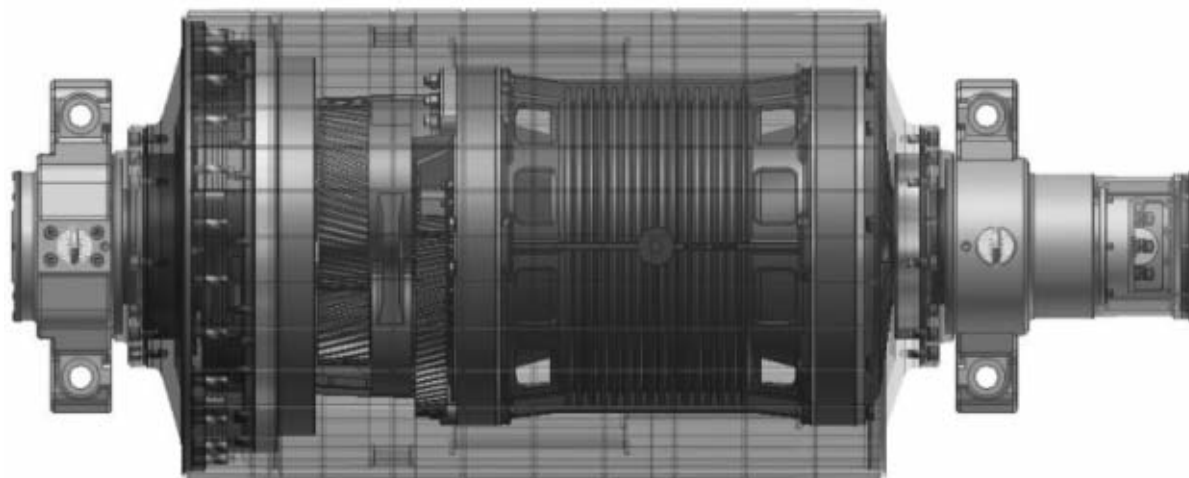



Offshore dredging in the North Sea featuring full capacity unloading at each docking to meet tide turn-round. Capacity: 2700 t/hr at up to 3.15 m/sec.

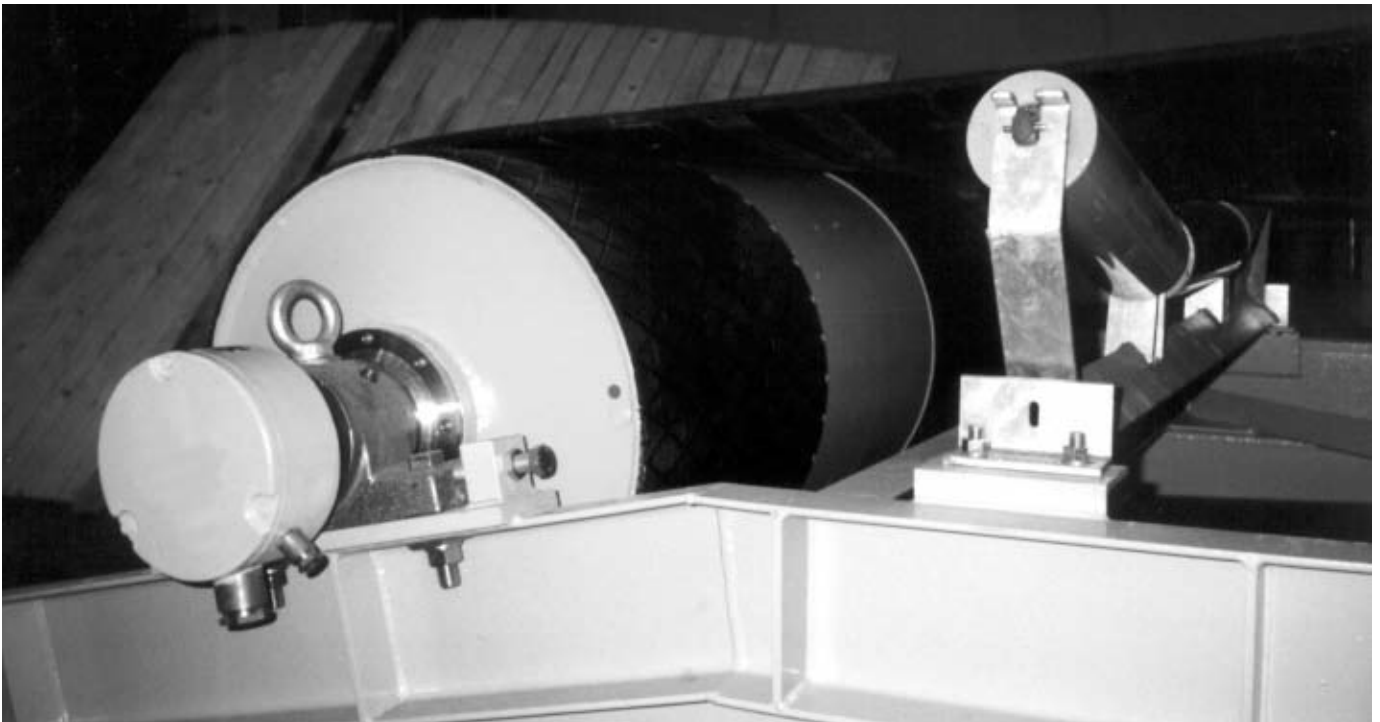

All Motorized Pulleys on-board vary from 37 to 75kW and have TS-11 finish and re-greasable IP66/67 seals as a MUST in salt water environment with hosedowns.



Motorized Pulleys in reversible shuttle conveyor. Application: Crushed granite. 5 Million tonnes per annum pass through this system.



Specification: Twin drive with 2 x 800M, 37.0 kW for this travelling reversible conveyor.



Applications in Special Environmental Conditions

Low ambient temperature

For low temperatures below -25°C please consult Rulmeca. Special oil, special seals, and possible anti-condensation heater may be required. Re-greasable seals to avoid drying out the labyrinth seals.

High ambient temperature

For high ambient temperatures above $+40^{\circ}\text{C}$ please consult Rulmeca.

Extremely dusty/ abrasive, wet/ high humidity

IP66/67 re-greasable seals, special finish, e.g. stainless steel – AISI 303/4 or even AISI 316, semi-rust-free, special coating, rubber lagging.

Grain handling - Extremely dusty where dangerous atmospheric conditions apply

Dust explosion proof Motorized Pulleys – ATEX 95 - Zone 22 – for applications handling dusty grain etc. Executions according to the European Directive 94/9/EC. This directive is known as “ATEX (Explosion Atmosphere) directive”.

Please contact Rulmeca for further details.

Frequent start/ stops

Type	Max. No. of Start/stops
138E	240 per hour
165E	180 per hour
220M & H	120 per hour
320L, 320M & 320H, 400L, 400M & 400H	25 per hour
500L, 500M, 500H, 630M & 630H, 800M, 800H/HD	10 per hour
1000HD	5 per hour

* For more frequent start/stops please consult Rulmeca.

Food handling applications

Re-greasable seals; Stainless steel versions in TS7N, TS9N or TS10N for high pressure and chemical wash down; food grade oil and grease; Food quality rubber lagging being oil, fat & grease resistant. FDA, USDA, FSIA & FESD recognized materials.

Underwater applications

Where IP66/67 specified, the Rulmeca Motorized Pulley has been tested for 30 minutes under 1 m of water. However, the motor is NOT intended for continuous underwater performances (IEC 529). If in doubt, please consult Rulmeca.

Indexing conveyor/ decline conveyor/ reversible inclined conveyor

Electromagnetic brake. Special shafts prepared to fit an external brake - 500H-1000HD.

Inclined conveyor (not reversible)

Mechanical backstop

Reversible conveyor

Sufficient time delay between forward and reverse. The Motorized Pulley must come to a complete stop before reversing.

Variable speed conveyor

Two speed motor. AC frequency converter.

Using a Motorized Pulley without conveyor belt or with a belt covering less than 2/3 of the Pulley face width

Use drives only from a special range of Motorized Pulleys developed for this purpose. Do not use standard Motorized Pulleys unless accepted by Rulmeca. Insulation class H, extra oil. Connect thermal protector.

Motorized Pulleys mounted non-horizontally between 5° - $\leq 90^{\circ}$

Special execution! Please consult Rulmeca. Extra oil, grease packed top bearing. Electrical outlet:

- To be re-positioned to the opposite end of standard
- To be positioned at the top when installed.

Impact load

Over-sized Motorized Pulley. Please consult Rulmeca.

Handling materials with oil, grease and fat content

Stainless steel version:

- 138E & 165E
- TS9N/TS10N (220M–400H).

Semi-stainless steel version:

- TS11N/ TS12N (220M–400H) or
- TS11/TS12 (400L–800H)

Food quality lagging being oil, fat and grease resistant.

High power rated motors. Starting under load

All RULMECA Motorized Pulleys are developed for direct starting (except 1000HD).

To reduce the starting current it is possible to use starting devices such as star/delta starter, electronic soft starter etc.

Please be aware that, when connecting a star/delta switch, the power of the motor will drastically be reduced and could cause overheating of the motor. If full torque is required during start a soft starter with torque boost should be used.

Extremely low noise/vibration requirements

Balanced shell. Special oil. Please contact Rulmeca for special solution.

Applications in Special Environmental Conditions

Marine environment. Ship loading/unloading conveyors etc.

Re-greasable IP66/67 sealing system and/or stainless steel or semi stainless options – TS7N, TS9N-TS12N or TS11-TS12.

Rubber or ceramic lagging.

High altitude >1000 m

Please consult Rulmecca.

Chemical and/or aggressive environments

Please consult Rulmecca.

Underground mining/tunnelling applications where possible dangerous atmospheric conditions apply or where the Motorized Pulley is to be flame proof or intrinsically safe

Rulmecca Motorized Pulleys are not intrinsically safe or explosion proof to meet these requirements. Please consult Rulmecca.

Critical speed requirements

Nominal speeds can deviate by +/- 10%. Where exact speeds are required, please consult Rulmecca.

Recycling, aggressive environments

Stainless steel shafts, re-greasable labyrinth seals, special painting and/or special oil.

Metal separators and metal detectors

Special execution as to amount of oil, type of bearings, electrical connection and built-in position.



Application: Fertilizer and potash.
Still in work after more than 30 years in an aggressive environment.



Power calculation BULK Handling

In order to calculate the necessary power required the following formula may be used:

$$P = \frac{C \times f \times L}{367} (3.6 \times Gm \times V + Qt) + \frac{Qt \times H}{367}$$

P = Necessary power (kW)

C = Frictional resistance in belts, bearings etc. (Fig. I)

f = Friction in conveyor Pulleys is fixed to 0.025 - 0.030.

L = Centre-to-centre distance between drum motor and idler Pulley (m)

Gm = Weight of belt and rotating parts in conveyor Pulleys as well as idler Pulley (Fig. II)

V = Velocity (m/sec.)

Qt = Capacity of the belt (t/h)

H = Lift (m)

B = Belt width (mm)

The power calculation does NOT include the extra power required for belt scrapers, ploughs, cleaners or receiving hoppers.

Fig. I Factor C

L (m) C	3 9.0	4 7.6	5 6.6	6 5.9	8 5.1	9 5.5	10 4.1
L (m) C	16 3.6	20 3.2	25 2.9	32 2.6	40 2.4	50 2.2	63 2.0
L (m) C	80 1.9	100 1.8	125 1.65	160 1.59	200 1.47	250 1.38	300 1.33
L (m) C	400 1.25	500 1.20	600 1.17	700 1.13	800 1.11	900 1.08	1000 1.05

Fig. II Gm (kg/m)

B (mm)	500	600	650	800	1000	1200	1400	1600	1800
Gm for standard conveyor	17	26	28	40	56	70	85	105	120
Gm for heavy and profiled belts	20	30	32	45	62.5	80	110	135	160

After choice of drum motor power, the required belt pull and power consumption may be calculated as shown below:

Required Torque

$$M = 500 \times \frac{D \times P}{V}$$

M = torque (Nm)

D = diameter (m)

V = speed (m/sec)

Required Belt Pull

$$F = \frac{1000 \times P}{V}$$

F = belt pull (N)

P = power (kW)

V = speed (m/sec.)

Power Consumption (Accurate to +/-20%)

$$I = 0.9 \times \frac{P \times 1000}{U}$$

I = power consumption(A)

P = power (kW)

U = voltage (V)

For more information please contact RULMECA or open our Web Page www.rulmeca.com, where you can download the latest edition of RULMECA's power calculation program.

Alternatively, please fill in the following pages and we will run the power calculation on your behalf.



APPLICATION WORKSHEET - BULK MATERIALS HANDLING

Motorized Pulleys

Complete this form and submit to Rulmeca for a power calculation and Motorized Pulley recommendation.

Contact Person _____ Date _____ Ref # _____

Company _____

Address _____

Phone _____ Fax _____ Email _____

What is the application? (Describe type of application, material and ambient conditions) _____

Abrasive Corrosive Very dirty Wet Wash Down Humid Dry Dusty Other _____

Standard Loading Conditions:

Conveyor Length (m) _____
 Tonnage Rate (tph) _____
 Belt Speed (m/s) _____
 Material Lift Height (m) _____
 Ambient Temperature (°C) Min _____
 Ambient Temperature (°C) Max _____
 Initial Velocity of Material (m/s) _____
 Number of Belt Cleaners _____
 Number of Belt Plows _____
 Length of Skirt Zone (m) _____
 Depth of Material in Skirt Zone (mm) _____
 Number of Non-driven Pulleys _____

Elevation (km)		Idler Roll Diam. (mm)		Type of Lagging	
<input type="checkbox"/>	1.0	<input type="checkbox"/>	108	<input type="checkbox"/>	Full
<input type="checkbox"/>	1.5	<input type="checkbox"/>	133	<input type="checkbox"/>	Partial
<input type="checkbox"/>	2.0	<input type="checkbox"/>	159	<input type="checkbox"/>	None
<input type="checkbox"/>	3.0				
<input type="checkbox"/>	4.0				
<input type="checkbox"/>	5.0				
<input type="checkbox"/>	Other				
Belt Width (mm)		CEMA Type		Type of Take-up	
<input type="checkbox"/>	500	<input type="checkbox"/>	A	<input type="checkbox"/>	Automatic
<input type="checkbox"/>	650	<input type="checkbox"/>	B	<input type="checkbox"/>	Manual
<input type="checkbox"/>	800	<input type="checkbox"/>	C		
<input type="checkbox"/>	900	<input type="checkbox"/>	D		
<input type="checkbox"/>	1000	<input type="checkbox"/>	E		
		Troughing Idler Spacing (m)		Angle of Wrap (deg)	
<input type="checkbox"/>	1200	<input type="checkbox"/>	180	<input type="checkbox"/>	180
<input type="checkbox"/>	1400	<input type="checkbox"/>	200	<input type="checkbox"/>	200
<input type="checkbox"/>	1600	<input type="checkbox"/>	210	<input type="checkbox"/>	210
<input type="checkbox"/>	1800	<input type="checkbox"/>	220	<input type="checkbox"/>	220
<input type="checkbox"/>	2000	<input type="checkbox"/>	240	<input type="checkbox"/>	240
		<input type="checkbox"/>	360	<input type="checkbox"/>	360
		<input type="checkbox"/>	420	<input type="checkbox"/>	420
Type of Belt					
<input type="checkbox"/>	1 ply, 160 piw				
<input type="checkbox"/>	2 ply, 225 piw				
<input type="checkbox"/>	3 ply, 330 piw				
<input type="checkbox"/>	4 ply, 440 piw				
Belt Carcass					
<input type="checkbox"/>	fabric				
<input type="checkbox"/>	steel cord				

Material (frictional coefficient)		
<input type="checkbox"/>	ashes, coal, dry	0.0571
<input type="checkbox"/>	bauxite, ground	0.1881
<input type="checkbox"/>	cement, Portland, dry	0.2120
<input type="checkbox"/>	cement clinker	0.1228
<input type="checkbox"/>	clay, ceramic, dry fines	0.0924
<input type="checkbox"/>	coal, bituminous mined	0.0754
<input type="checkbox"/>	coke, ground fine	0.0452
<input type="checkbox"/>	cullet (broken glass)	0.0836
<input type="checkbox"/>	grains, wheat, corn, rye	0.0433
<input type="checkbox"/>	gravel, bank run	0.1145
<input type="checkbox"/>	iron ore, 200 lbs/cu ft	0.2760
<input type="checkbox"/>	limestone, pulverized dry	0.1280
<input type="checkbox"/>	phosphate rock, dry	0.1086
<input type="checkbox"/>	salt, common, dry fine	0.0814
<input type="checkbox"/>	sand, dry, bank	0.1378
<input type="checkbox"/>	wood chips	0.0095

Material Bulk Density (kg/m³)		
<input type="checkbox"/>	ashes, coal, wet	800
<input type="checkbox"/>	bagasse	160
<input type="checkbox"/>	bark, wood	320
<input type="checkbox"/>	bauxite, ground, dry	1090
<input type="checkbox"/>	bauxite, crushed	1370
<input type="checkbox"/>	beans, navy, dry	770
<input type="checkbox"/>	beets, whole	770
<input type="checkbox"/>	borax, 3" & under	1120
<input type="checkbox"/>	cement, portland	1590
<input type="checkbox"/>	clay, ceramic, dry, fines	1280
<input type="checkbox"/>	clay, dry, fines	1920
<input type="checkbox"/>	coal, bituminous	880
<input type="checkbox"/>	coal, lignite	720
<input type="checkbox"/>	coke	720
<input type="checkbox"/>	corn, ear	900
<input type="checkbox"/>	cullet	1920
<input type="checkbox"/>	gravel, bank run	1600
<input type="checkbox"/>	iron ore	3200
<input type="checkbox"/>	iron ore pellets	2080
<input type="checkbox"/>	limestone, crushed	1440
<input type="checkbox"/>	paper pulp stock	960
<input type="checkbox"/>	phosphate rock	1360
<input type="checkbox"/>	potash salts	1280
<input type="checkbox"/>	rock, crushed	2320
<input type="checkbox"/>	rock, soft	1760
<input type="checkbox"/>	rye	740
<input type="checkbox"/>	salt, common dry, fine	1280
<input type="checkbox"/>	sand, bank, damp	2080
<input type="checkbox"/>	sand, bank, dry	1760
<input type="checkbox"/>	sand, foundry	1600
<input type="checkbox"/>	sawdust	210
<input type="checkbox"/>	sewage sludge, moist	880
<input type="checkbox"/>	soybeans, whole	800
<input type="checkbox"/>	sugar, raw, cane	1040
<input type="checkbox"/>	taconite pellets	2080
<input type="checkbox"/>	traprock, 2-3" lumps	1760
<input type="checkbox"/>	wheat, cracked	720
<input type="checkbox"/>	wood chips	480

Operating Conditions:

Duty Cycle (Start/stops per hour) _____
 Hours of Operation (hrs/day) _____
 Days of Operation (days/week) _____
 Is this a reversing belt? _____
 Additional Comments: _____

Special Loading Conditions:

Hopper Feeder Parameters:
 Hopper Opening Width (mm) _____
 Hopper Opening Length (mm) _____

Slider Bed Parameters:

Slider Bed Length (m) _____

Slider Bed Material (frictional coefficient)		
<input type="checkbox"/>	steel	0.90
<input type="checkbox"/>	UHMW polyethylene	0.545
<input type="checkbox"/>	urethane	0.88
<input type="checkbox"/>	wood	1.00

Sidewall & Cleated Belt Parameters:

Sidewall & cleat height (mm) _____
 Thickness of sidewall (mm) _____
 Distance between cleats (mm) _____
 Thickness of cleats (mm) _____

Tripper Design Parameters:

Tripper Length (m) _____
 Tripper Material Lift Height (m) _____
 Number of Tripper Belt Cleaners _____
 Tripper Skirt Zone Length (m) _____
 Depth of Material in Skirt Zone (mm) _____
 No. of Tripper Non-driven Pulleys _____
 No. of V-ploughs _____

For free "downloadable" power calculation program, complete with definitions of all terminology, go to www.rulmeca.com.

Frequency Hz 50/60 _____ Hz

OPTIONS:

Lagging? Rubber? Black? White? Smooth? Diamond?
 Ceramic? Oil, fat & grease? Thickness? _____ (mm) Dust explosion proof - ATEX - Zone 22
 Matching terminal box Dualdrive
 With cable Straight connector Elbow connector 90°
 Food application Re-greaseable labyrinth seals Non-regreaseable
 Reversible belt Electromagnetic brake Total in stainless steel labyrinth seals
 Mechanical backstop Clockwise direction Parallel shell (cylindrical)
 Idler Pulley Qty: _____ Mounting bracket Qty: _____

NOTES: special options _____

Please attach a photo, drawing or sketch of the application

Technical Precautions for Design, Installation and Maintenance

⚠ WARNING Read and follow all safety instructions!
 These instructions contain important sections relative to safety, use, Maintenance, parts replacement and other technical information. Always include these instructions with the pulley.



Contents

Installation & Maintenance

- a) **Transport and Handling**
- b) **Motorized Pulley Mounting Orientation**
- c) **Mounting Brackets**
- d) **Electrical Installation**
- e) **Motor Current Overload and Over current Protection**
- f) **Thermal Protection**
- g) **Belt Tension**
- h) **Belt Alignment**
- i) **Start-up**
- j) **Lagging**
- k) **Rubber lagging limitations**
- l) **Actual Belt Speed vs. Nominal Belt Speed**
- m) **Ambient Temperature**
- n) **Surface Coating**
- o) **Belt Pull**
- p) **Mechanical Backstops**
- q) **Electromagnetic Brake**
- r) **Reversing Conveyors**
- s) **Oil and Oil Seal Maintenance**
- t) **Re-greasable labyrinth seals**
- u) **Pulley Diameter**
- v) **Terminal Box**
- w) **Variable frequency drive**
- x) **Capacitors**
- y) **Maintenance**
- z) **Aftermarket Service**
- aa) **Winding Diagrams**
- bb) **Non-Belt, Partial Belt, Modular Belt**
- cc) **Storage of Motorized Pulleys**
- dd) **Dust explosion proof motorized pulleys (ATEX 95)**
- ee) **Guarantee**
- ff) **Oil types and Contents List**
- gg) **Allowable Belt Tensions**

IMPORTANT INFORMATION!

- After unpacking the pulley, inspect carefully for any damage that may have occurred during transit. Check to be sure all supplied accessories are enclosed with the unit. If you have questions regarding safety or damaged or missing parts, please call one of your nearest RULMECA representative listed at the back of the manual.
- It is the responsibility of the contractor, installer, owner and User to install, maintain and operate the conveyor, components and conveyor assemblies in such a manner as to comply with:
 The Williams-Steiger Occupational Safety and Health Act and with any and all state and local laws and ordinances as to the national and international standards as to:
 - ANSI – B20.1 Safety Code and Conveyor Equipment Manufacturers Association (CEMA) voluntary consensus standards which may prevail,
 - ANSI – Z535 Warning label Series
 - ISO 3864-2 Product Safety labels

When existing equipment is being retrofitted, upgraded or even changed, it is in customer's best interest to bring the equipment up to today's standards. If there are any questions, please contact RULMECA.

NOTICE

Refer to page 92 for explanation of the safety symbols used in this section of the catalogue.



Do not install standard motorized pulleys in areas with potentially explosive concentrations of vapors, gases, mists and dust.

Read the manual before installing or operating the pulley. Failure to understand how to install or operate the Pulley could cause personal injury or even death. Any modification made to or unintended use of the pulley could create a hazardous condition that could cause death or serious injury. Precautions which could effect warranty or create hazardous condition are marked with a safety symbol.



The drum motor must not be put into service until the machinery into which it is incorporated has been declared in conformity with the provision of the Directive 98/37/EEC & amendments.

Also for testing the motor shafts have to be fixed to a frame properly before it is connected to the power supply and switched on. The shell has to be protected against accidental contact because of rotating.

a) **Transport/Handling:**

- For safety reasons during transport and assembly a lifting rope according to the max. weight of the Pulley has to be used. The weight of the Pulley is stamped on the data plate and /or given in the catalogue.
- The rope has to be fixed on the shaft ends.
- As to Motorized Pulley types 500H – 1000HD, a steel rope or chains should be fixed to the eyebolts, which are located on the mounting brackets.

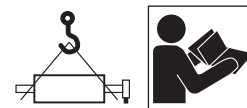

b) **Motorized Pulley Mounting Orientation:**

- Before installing the Motorized Pulley, please ensure that the data plate information is correct to your specification.
- At any time, Rulmecca Motorized Pulleys should always be mounted so that the Pulley shafts are
 1. Horizontal,
 2. Parallel to idler rollers, and
 3. Perpendicular to the conveyor belt **centreline**.
- As to Motorized Pulley types 138E to 500M “UP” is indicated with the word “UP” stamped on the Pulley shaft.
- All Motorized Pulleys are to be mounted as shown on the sketch below.

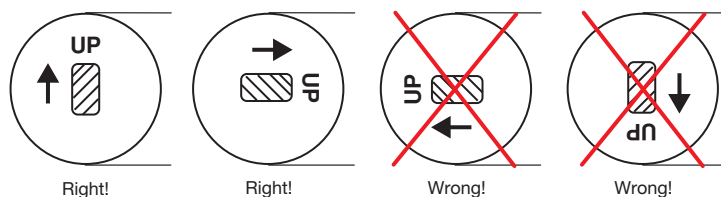
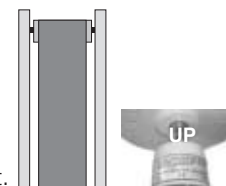

NOTICE

- This instruction **does not** apply to types 500H - 1000HD.
- In case of a non-horizontal installation, of more than +/-5 degree, please consult Rulmecca.
- For Motorized Pulley types 500H - 1000HD please ensure that: Motorized Pulley's are positioned in such a way that the mounting brackets are located horizontal or vertical to the conveyor frame. The cable entry of the terminal box should be located downwards or in a 90° position.

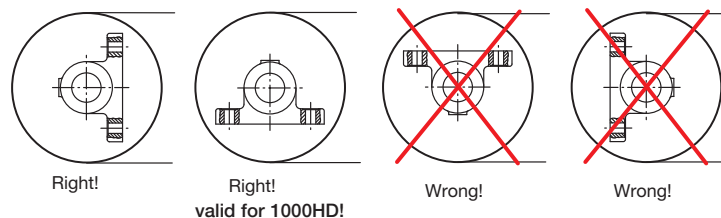
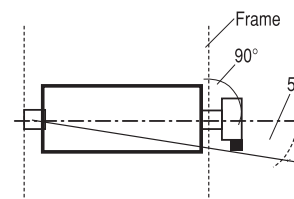

NOTICE

- At any time all Rulmecca Motorized Pulleys shown in this catalogue must be fitted with a conveyor belt to prevent overheating.

Motorized Pulleys fitted without a belt must be referred to Rulmecca.

- Installation and mounting of the Motorized Pulley in another position as described could cause severe product damage and voids product warranty.

c) **Mounting Bracket:**

- As listed in the catalogue, use the **correct Rulmecca** mounting brackets matching the respective types of Motorized Pulleys.
- Note that it is physically possible, but **not** permissible, to interchange mounting brackets between models. Mounting brackets designed for smaller diameters or lower-powered Pulleys may **not** be used for larger diameters or higher-powered Pulleys.
- Mounting brackets must be mounted to frame in such a way that belt pull is resisted by the shoulder or base of the mounting bracket. Motorized Pulleys types 138E to 500M have a top shaft retaining plate. This plate is **not** designed to resist belt pull.

NOTICE

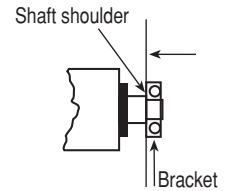
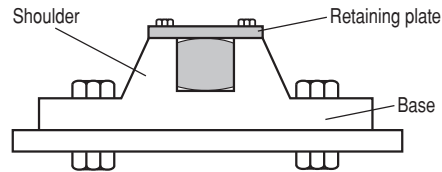

- The designer must select appropriate mounting bolts to resist belt forces and/or the weight of the Pulley depending on the mounting position of the Pulley.
- All types of mounting brackets must be fully supported by and fastened to the conveyor frame in such a way that the shafts ends **do not** deform. Shaft ends must always be fully supported by the brackets.
- Where solid mounting brackets type AL and ALO are used, the brackets have to be assembled close to the shoulder of the round shaft. This is to ensure that the drum motor has no axial clearance.
- The AL type of bracket is fitted with one or two keys depending on load.
- Keys must be securely fixed and checked regularly and locked if necessary.
- Mounting brackets should be fitted in such a way that they are in contact with the shoulder of each shaft. This will:
 1. Eliminate Motorized Pulley axial play between mounting brackets.
 2. Keep shaft deflection to a minimum.

NOTICE

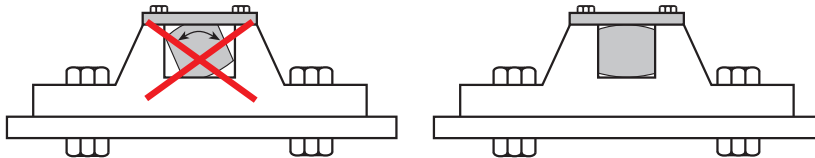

- In noise-sensitive areas, the designer should use heavier gauge support structure and appropriate vibration isolating material, as necessary.
- When **Rulmeca Motorized Pulley mounting brackets are NOT used**, it is essential that:
 1. The mounting equipment supports at least 80% of the shaft flats.
 2. It has to be assembled without any clearance between the support and the shoulder of the shaft.
 3. The clearance between the shaft flats shoulder and the support should be less than 0.4 mm (torsion play).
- A Motorized Pulley with frequent reversible operations or many start/stops should be mounted with **NO** axial clearance between the shaft flat shoulder and the brackets
- Failing to follow these precautions could cause Pulley and/or mounting bracket damage and *voids product warranty*.

NOTICE

d) **Electrical Installation:**

- Always use licensed electrician to install the unit. All electrical installation and wiring shall Conform to the national code of the National Electrical Standards. Turn the electrical power off at the electrical panel board (circuit breaker or fuse box) and lock or tag the panel board door to prevent someone from turning on power while you are working on the unit, failure to do so could result in serious electrical shock, burns or possible death. According to the European Council Directives related to machinery, the equipment manufacturer (OEM) has to secure that the Motorized Pulley is NOT put into operation before it is
 - Correctly installed,
 - Correctly connected to the power supply,
 - Correctly protected against rotating parts.
- A specialist must perform the electrical connection of the Motorized Pulley in accordance with electrical regulations. If in doubt, contact Rulmeca.
- A wiring diagram is always supplied with the Motorized Pulley. Always refer to the connection instructions and ensure that the motor power and control circuits are properly connected.
- The wiring diagram is inserted in the accompanying booklet and into the terminal box.
- As standard, Rulmeca Motorized Pulleys are delivered with clockwise rotation when viewed from the terminal box end of the Motorized Pulley.
- Always refer to the connection instructions and ensure that the motor is connected as required to the correct mains supply.

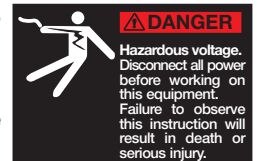

Earth connection





- As a safety measure, please use the **earth screw** located in the terminal box.
 - The protective conductor has to be connected to the earth screw.
 - When using cable options the green/ yellow wire has to be connected to the protective conductor of the main supply.
- All safety devices, including wiring of electrical safety devices itself will not result in a hazardous condition.**

e) **Motor Current Overload and Over current Protection:**

- Motor control systems must include protection against operating Pulley motors in excess of Full Load Amperage (FLA.). The control system should also include protection against voltage spikes and excessive jogging of motors. Failing to provide adequate current overload and over current protection could stress the motor and **voids product warranty**.
- FLA data is available for all motors upon request. FLA data is also supplied on motor label for each Motorized Pulley.
- Electrical power, control, and protection for Motorized Pulleys must adhere to all pertinent regulations.

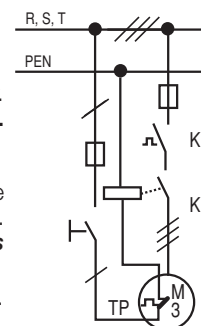

f) **Motor Thermal Protection:**

- **All Motorized Pulley motors are supplied with a built-in thermal protector in each phase.**

Protection consists of heat-sensitive, bi-metallic switches built into each motor phase winding. The switches are designed to open if motor temperature elevates to an inappropriately high level. 2.5 Amps are the permissible current of standard versions.

The voltage is 230V.

- These switches must be connected to a normally closed control circuit (in series with a magnetic coil/relay device and contactor) in order **to validate product warranty**.
- A motor control circuit should kill motor power if thermal switch opens. Thermal switches will automatically close as motor cools. Cooling times vary with Pulley model, power, and size. However, 30 to 60 minutes is common with most motors in an ambient temperature of 20°C.



g) **Belt Tension:**

- The conveyor belt should never be over-tensioned. It should be installed with **sufficient belt tension only** to prevent belt slippage.

Refer to the motorized pulley range for the list of belt tension!

- To keep the radial load as low as possible to drive the belt without slipping anti-slip lagging should be used.
- Maximum allowable radial load of each Motorized Pulley (MP) is specified in this catalogue. Subjecting the Motorized Pulley to a higher than specified maximum radial load may damage internal components and shorten product lifetime and, therefore, **voids product warranty**.
- To check Pulley radial load, do a vector summation of the loads on the Pulley.
- For example, as shown in the diagram,

1. Radial load equals $T_1 + T_2$.

2. T_1 , tight side tension, equals Belt Pull (F_u) plus T_2 .

3. T_2 , slack side tension, is determined using CEMA standard calculations or DIN 22101 to provide enough friction between the Pulley and the belt to drive the belt.

Belt type, belt thickness and the right diameter of the Pulley have to be selected according to Belt Supplier Requirements.

NOTICE

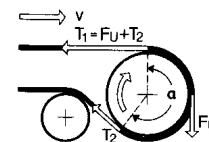

h) **Belt Alignment:**

- Motorized Pulleys must be installed with Pulley shaft perpendicular to belt centreline and parallel to all idler rollers.
- Belt centreline must be straight and parallel to side walls of slider bed (if any) and perpendicular to idler rollers and all Pulleys
- Belt and/or roller misalignment may cause high friction and overload the conveyor belt drive motor.
- Belt misalignment may cause premature wear of Pulley lagging.

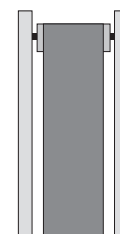

i) **Start-up:**

• **Prior to initial start-up of Motorized Pulley:**

- Verify that Motorized Pulley nameplate data matches customer specification.
- Ensure electrical connections are correct.
- Check that Motorized Pulley is free to rotate.
- Check that slack side belt tension is adequate to prevent belt slippage.
- Check that belt is not over-tensioned.
- Ensure the oil is present in the Motorized Pulley.



j) **Lagging:**

- Smooth and diamond pattern lagging is available in black synthetic rubber and white synthetic rubber. Approximate rubber hardness is 65 durometer (shore hardness A).
- Standard lagging is cold-bonded to Pulley shell.
- Optional hot vulcanised lagging is available for high power/high torque/high temperature applications and for Motorized Pulleys with Class H motors.
- Oil & grease resistant synthetic rubber is also available for oily operating conditions and/or for certain types of belting material. Check with belting supplier if belt/lagging material compatibility could be a problem.
- Adequate Motorized Pulley heat dissipation is necessary.

Lagging thickness and width greatly affect Pulley heat dissipation characteristics!

k) **Lagging Limitations:**

Motorized Pulley type /power	RL (mm)	Cold bonded 3mm	Cold bonded 5mm	Cold bonded 6mm	Hot vulc. 6mm	Cold bonded 8mm	Hot vulc. 8mm	Cold vulc. 10mm	Hot vulc. 10mm	Partial hot vulc. 10mm	Partial cold vulc. 10mm	Ceramic 10mm, moulded or direct glued	Ceramic/ rubber 10mm
138E up to 0.37kW 0.55 & 0.75 & 1.0kW 0.55 & 0.75 & 1.0kW 0.55 & 0.75 (>= 0.63m/s)	up to 599 from 600 from 600	x x x x	x x x x	x - x x	x - - x	x - - x	x - - x	- - - x	- - - x	- - - -	- - - -	- - - -	- - - -
165E up to 0.75kW 1.1 & 1.5kW 1.1; 1.5 kW 1.1; 1.5 kW (>=1.25m/s)	up to 599 from 600 from 600	x x x x	x - x x	x x x x	x - - x	x - - x	x - - x	x - - x	x - - x	- - - -	- - - -	- - - -	- - - -
220M & 220H up to 1.5kW 2.2 & 3.0kW dito 4.0kW dito 5.5kW dito	from 400 up to 799 from 800 up to 699 from 700 up to 849 from 850	x x x x x x x	- - - - - - x	x x x - x - x	x x x - x - x	x - x - - - -	x - x - - - -	x - - - - - -	x - - - - - -	- - - - - - -	- - - - - - x	x x x x x x x	- - - - - - -
320L – 320H up to 5.5kW 7.5kW < RL1000 7.5kW > RL1000	- - -	x - -	x - x	x - x	x x x	x - -	x - -	- - -	- - -	- - -	- - -	x x x	- - x
400L	-	-	-	x	x	x	x	x	x	x	x	x	x
400M & 400H up to 11.0kW 15.0kW (<= 1.6m/sec.) 15.0kW (> 1.6m/sec.) 15.0kW (>= 1.6m/sec.) 15.0kW (>= 1.6m/sec.)	- - up to 1149 from 1150 from 1600	- - - - -	- - - - -	x - - - -	x - - x x	- - - - x	x x - - x	- - - - -	- - - - -	x x x x x	- - - x x	x x x x x	x - Partial Partial x
500L & 500M up to 15.0kW	-	-	-	-	-	x	x	-	-	x	x	x	x
500H up to 18.5kW 22.0kW 30.0kW	- - from 1050	- - -	- - -	- x -	- - -	x - -	x x -	- - -	- - -	x x -	x x -	x x x	- x Partial
630M	-	-	-	-	-	x	x	-	x	x	x	x	x
630H 22.0kW 30.0kW (<1.6m/sec.) 30.0kW (>=1.6m/sec.) 37.0kW 45.0kW 45.0kW 55.0kW	- - - up to 1299 from 1300 -	- - - - - -	- - - - - -	- - - - - -	- - - - - -	x - - - - x	x - x - - x -	x - - - - - -	x x x - - - x	x x x - - - x	x x x x x x	x x x x x x	x x Partial Partial Partial x Partial
800M 45.0kW 55.0kW	- - -	- - -	- - -	- - -	- - -	x - -	x - -	x - -	x - -	x - x	x - -	x x x	x x x
800H 55.0kW 55.0kW 75.0kW 75.0kW up to 132.0kW	up to 1299 from 1300 up to 1299 from 1300 -	- - - - -	- - - - -	- - - - -	- - - - -	- - - - x	- x - - -	- - - - -	- x - - -	x x x x x	- - - - -	x x x x x	Partial Partial Partial Partial Partial
1000HD 160.0kW 200.0kW 250.0kW	- - -	- - -	- - -	- - -	- - -	- - -	- - -	- - -	- - -	- - -	- - -	x x x	- - -

l) **Actual Belt Speed vs. Nominal Belt Speed:**

- Two key specifications for each Motorized Pulley are Power (kW) and nominal belt speed (m/sec.), as given in the respective specifications in this catalogue.
- Nominal belt speed is a design target, providing consistent choices among all models and powers.
- Actual full load belt speed is almost never exactly equal to nominal belt speed.
- Actual belt speed is a function of the motor pole numbers, gear ratio and load. This catalogue displays the nominal belt speed at 50Hz.
- Note that **all** belt speeds shown in this catalogue refer to **un-lagged Pulleys** because:
 1. Belt speed for each model is a function of Pulley diameter,
 2. Pulleys are available with and without lagging,
 3. Lagging changes the Pulley diameter,
 4. Various lagging thickness are available.
- Note that each Rulmecca Motorized Pulley for a three-phase power supply uses an asynchronous squirrel cage induction motor with about 5% slip. In a no load condition, motor RPM is nearly equal to “synchronous speed” RPM. The slip rate is dependent on power and design of the motor. Low powered motors have a lower slip rate than high-powered motors. At full load, the motor RPM is about 5% less than synchronous.
- Pulley by Pulley the “nominal belt speed” displayed in this catalogue is based on un-lagged Pulleys running at full load, nominal voltage (e.g. 400V) and 50Hz.
- The nominal full load belt speed of a lagged Pulley running at
 1. Full load,
 2. Nominal voltage (e.g. 400 volts),
 3. 50 Hz
 – equals the nominal full load belt speed specified in this catalogue, times the ratio of the lagged/un-lagged Pulley diameters.

NOTICE

Example: A 4.0kW Motorized Pulley 320M with an un-lagged Pulley diameter of 321mm has a nominal belt speed of 0.8 m/sec.

The actual belt speed is a function of

- The rotor speed (RPM),
- Gear ratio,
- Shell diameter and
- Load.

E.g. the above mentioned 320M with a nominal belt speed of 0.8m/sec. has

1. A gear ratio of $i = 28.6$,
2. A rotor speed of $n = 1440$ (1/min),
3. A shell diameter of 0.321 m.

The actual belt speed at full load is

$$v \text{ (m/sec)} = \pi \times d \text{ (m)} \times n \text{ (1/min)} / 60 \times i$$

π = Pie (3.14),

d = Pulley diameter,

n = revolutions per minute,

i = gear ratio

$$v = (3.14 \times 0.321 \text{ m} \times 1440 \text{ 1/min}) / (60 \times 28.6) = 0.85 \text{ m/sec.}$$

If this Pulley is supplied with 10mm thick lagging, the belt speed of the lagged Pulley equals **0.85m/sec. x (0.341m/0.321m) = 0.90m/sec.** at full load, nominal voltage and 50Hz.

m) **Ambient Temperature:**

- Motorized Pulleys are normally cooled by dissipating heat through contact between the surface of the Pulley and the conveyor belt. It is essential that each Pulley have an adequate thermal gradient between the Pulley's motor stator and its ambient operating temperature.
- All Motorized Pulleys in this catalogue are designed and tested under full load without rubber lagging for a use in a max. ambient temperature of +40 °C. degree.
- **Rubber lagging and/or higher ambient temperatures than +40 °C as well as conveying hot material will reduce the heat transfer from the electrical motor through the Pulley body to the air and/or the conveyor belt. This will always switch off the motor winding protection switch (motor thermal protection) and could**



NOTICE



possibly end-up in a burned motor winding.

- **Example:** A conveyor is running in a facility with an ambient temperature of 45 °C. The temperature of the motor cannot be dissipated as it should be. The motor temperature will increase to a dangerous level.
- **Example:** A conveyor belt in an application with an ambient temperature of +24 °C, carrying processed material at a temperature of +70 °C, will have a Motorized Pulley “ambient temperature” that is significantly higher than +40 °C.

In this case, the temperature of the material is higher than the max. allowed ambient temperature which is necessary for a proper heat dissipation. A situation is then created due to **heat accumulation (heat storage) between the bottom of the belt and the Motorized Pulley body.**

- For ambient operating conditions lower or higher than allowable ambient temperature (-25 °C to 40 °C), contact Rulmeca.
- In many cases it is possible to use specially designed Motorized Pulleys to perform tasks for special applications – e.g. modular plastic belts and v-belts for Motorized Pulley types 138E & 165E. Please contact Rulmeca for such applications.
- Operating Rulmeca Motorized Pulleys to drive standard conveyor belts outside of the allowable ambient temperature range voids product warranty.

NOTICE

n) **Surface Coating:**

- The Motorized Pulley types 400L to 1000HD are supplied with a salt water resistant primary paint coat of 60µm. For aggressive environmental conditions the Motorized Pulley should be painted to a thickness of 120µm.
- In this case it is essential to ensure that no paint material enters the gap between the shaft and the end housing to prevent possible damage to the shaft sealing.
Motorized Pulley types 220M to 320H are supplied with high resistant powder coated end housings. The shells and shafts are treated with anti-rust wax.



o) **Belt Pull:**

- The catalogue specifies “Actual Belt Pull” for each model, power, and speed of Pulley. Note that the specified actual belt pull allows for motor and gearbox efficiency losses (95 – 97%).
- Always select the Motorized Pulley power by comparing calculated “required belt pull (F)” with “Actual Belt Pull” and not simply on the basis of calculated Power (kW).
- Belt pull “F” is a summary of all of the existing forces to convey the material. E.g.
 1. F1 - force to move the belt,
 2. F2 - force to accelerate the material,
 3. F3 - force to lift or lower the conveyed material,
 4. F4 - force to clean the belt,
 5. F5 - force to overcome the skirt board friction or roller resistance,
 6. F6 - force to frictional resistance of ploughs, etc.

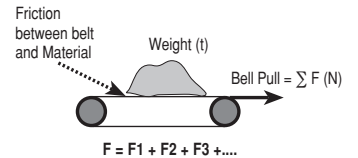

Furthermore, with special application additional power requirements can be needed (e.g. for belt operating under a hopper, squeezing of belt, belt guiding, extreme stiff belts etc.).

p) **Mechanical Backstops:**

- Motorized Pulleys fitted with mechanical backstops are used on inclined conveyors to prevent run back of the loaded belt when power supply is off.
- The backstop is built into the Motorized Pulley and is mounted on the rotor shaft.
- If Pulley is supplied with optional mechanical backstop, direction of proper rotation of Pulley is indicated by an aluminium arrow or plastic sticker fastened to the end housing on the terminal box (or power cord) side of the Pulley. Clockwise or counter clockwise backstops are available.
- **Rotation direction is to be specified when placing the order.**
- Pulley rotation is specified from the point of view of a person looking at the Pulley from the terminal box (or power cord) side of the Pulley.
- It is essential that the identity of each of the three phases of the power supply be determined before attaching power supply wires to the Pulley to prevent motor from driving against the backstop. The identity of each of the three phases of the motor is clearly labelled on the terminal board, terminal strip, or wires (in power cord type).
- Driving the motor against the mechanical backstop may damage motor and/or backstop and voids product warranty.

CAUTION



q) **Electromagnetic Brake:**

- The spring-loaded electromagnetic brake is intended for use as a conveyor belt holding brake and a positioning brake.
- The control circuit for the Motorized Pulley motor and brake must be designed to stop the Pulley motor before brake clamps are shut and start the Pulley motor after the brake is released.
- Spring-loaded electromagnetic brakes are designed to release when power is applied to the brake coil. This is a “fail safe” feature. The clamp shuts when brake power is removed (either during normal operation or during an emergency loss of overall system power.)
- **Control circuits must be designed so that motor and brake NEVER work against each other. The brake should never be clamped shut when the motor is on except for “emergency stop” condition. The motor should never be powered on (including “jog” command) when the brake is clamped shut.**
- Electromagnetic brakes are DC-powered. They are supplied with AC to DC rectifiers to be mounted in a remote panel (by others). Rectifiers must be fuse-protected.
- Motor control circuits must be designed to kill motor power in the event of loss of brake power. If this safety provision is not made, it is possible for Pulley motor to be “powered through” a clamped brake, burning brake and/or motor.
- A wiring diagram is supplied with every Motorized Pulley. Always ensure that motor and brake power and control circuits are connected according to instructions.
- For rectifier connection and protection instructions, refer to rectifier data sheet supplied with Motorized Pulley.
- **Neglecting these instructions could cause damage to the motor and/or brake and voids product warranty.**

NOTICE

r) **Reversing Conveyors:**

- All Motorized Pulleys for a three-phase power supply are reversible. Mechanical backstop option is not possible for reversible conveyor applications.
- The conveyor drive control system must be designed to bring the Motorized Pulley to a complete stop before reversing conveyor belt direction.
- **Reversing conveyor direction without stopping the drive motor will damage motor and gearbox and voids product warranty.**

NOTICE

NOTICE

s) **Oil and Oil Seal Maintenance:**

- Oil type and contents are given on the motor nameplate.
- Standard, synthetic, food grade, low viscosity (for low temperature applications,) and high viscosity (for noise-sensitive areas) are all available. For approved oil types and quantities, see pages 96-97.
- Motorized Pulleys require periodic oil changes and are supplied with two oil fill/drain plugs in end housing.
- Under normal operating condition the standard filling of the mineral oil should be changed after 20,000 operational hours. This is due to normal wear of gears.
- Synthetic oils should be changed after each 50,000 hours of normal operating condition.
- Magnetic oil plug(s) should be cleaned during each oil change. A red dot plastic sticker indicates the position of the magnetic oil plug.
- Only approved non-conductive oil may be used in Motorized Pulleys.
- Note that oil seals, regardless of oil type used, should be changed after 30,000 operating hours. On Motorized Pulley types 320M to 1000HD oil seals may be changed **without** removing Motorized Pulley from conveyor. Motorized Pulley standard types 220M to TM320L require Pulley disassembly to change oil seals. Rulmecca service personal or authorized local service providers to perform this work.



Take special precautions when changing brands of oil and types of oil because of potential oil incompatibility. Contact your local oil supplier for assistance.

NOTICE

- **For example**, when changing from standard to synthetic oil, it is necessary to:
 1. Completely drain old standard oil;
 2. Partially fill Pulley with “Clean-Flush-Lubricate” (CFL) fluid;
 3. Run Pulley for 20 minutes;
 4. Drain CFL fluid completely; then
 5. Fill Pulley with appropriate amount of new synthetic oil.



- Failing to observe these oil and oil seal precautions could shorten Pulley service life and **voids product warranty**.
- **All the above instructions refer to Motorized Pulleys CONSTANTLY working under FULL LOAD. In case of Motorized Pulleys NOT working continuously under full load, the service life will increase considerably! When checking the oil, the cleanness of the oil is always the best guideline of**
 - **The wear and present position of the gears and bearings**
 - **Whether to change the oil immediately**
 - **Whether it is possible to delay the oil change.**

NOTICE

t) **Re-greasable labyrinth seals:**

- All Rulmeca Motorized Pulleys are hermetically sealed. Standard oil seals are designed to contain oil within the Motorized Pulley during normal operating conditions. They are capable of withstanding an internal pressure rise that occurs as the Pulley motor temperature increases.
- Optional re-greasable labyrinth seals are available to protect oil seals from harsh operating or maintenance conditions. Each labyrinth seal provides a barrier of steel and grease to prevent ingress of dust and fluid through the oil seal.
- In abrasive operating conditions labyrinth seals should be periodically grease-purged to flush abrasive dust away from the oil seal.
- In wet and/or dirty conditions, where it is common to wash down equipment with high-pressure detergent spray, labyrinth seals should be refilled with grease after each wash-down. High-pressure sprays remove grease from the labyrinth seal, removing an important part of the barrier to fluid ingress.
- It has to be secured that grease is always seen at the labyrinth gap.
- If in some circumstances the re-grease frequency is too high a so-called “Grease Man” is recommended.
- Failing to perform necessary labyrinth seal maintenance could shorten service life and **voids product warranty**.

NOTICE

u) **Pulley Diameter:**

- The type and size of conveyor belt will determine the minimum allowable Motorized Pulley diameter. Using a too small Pulley diameter, which does not match the belt, can cause belt de-lamination, belt splice damage and can shorten both belt and Pulley lagging life. Always contact your belting supplier before specifying a Pulley diameter.

v) **Terminal Box:**

- **Rulmeca** Motorized Pulleys are available with terminal boxes or power cords to facilitate electrical installation. Motorized Pulleys with power cords are available up to 4kW.
- Two main types of terminal boxes are used:
 1. A **compact terminal box** equipped with clamp terminals “WAGO” used for Motorized Pulley types up to 4.0 kW
 2. **Larger terminal boxes** with traditional threaded brass terminals.
- Switch off Motorized Pulley power supply and control circuit(s) before opening terminal box.
- Each terminal box has one or more conduit nipples and a cover plate. The cover plate should be removed to facilitate termination of power and control wires within the terminal box. After wire connections are made cover plate should be replaced.
- Terminal boxes should never be disassembled or removed from the end of the shaft to reorient conduit nipple location.
- Modifications to terminal boxes should only be made by an authorized **Rulmeca service centre** or after obtaining permission and instructions, in writing, from **Rulmeca**.
- A wiring diagram is placed inside the terminal box on the back of the terminal box cover.



Dismantling and reassembling terminal boxes could cause short circuits within the internal wiring, which is factory set (and tested) and would void product warranty.

NOTICE

w) **Frequency Converter:**

- It is essential that each Frequency Converter be set within the motor's allowable operating spectrum. For Rulmeca Motorized Pulleys the allowable frequency spectrum is 15 Hz to 65 Hz. There will be no more than 5% torque loss within this range. This means that a Rulmeca Motorized Pulley is essentially a “constant torque” conveyor belt drive within the allowable frequency range.



- If operators attempt to drive the motor outside of the allowable range, then torque loss becomes significant, motor current draw elevates, motor cooling can become problematic, and *product warranty is void*.
- Do not allow resonant frequencies in the power line to cause voltage spikes in the motor. It is possible for the Frequency Converter to set up resonant frequencies in the power line between the Frequency Converter and the motor if the power line isn't too long. Potential resonant frequencies may be eliminated in two ways. Either by limiting the distance between the Frequency Converter and the motor (some Frequency Converter manufacturers recommend cable lengths of 10m or less) or simply install a filter on the Frequency Converter output (available from Frequency Converter manufacturer.)
- To avoid any radio-interference the cable from Motor to the Frequency Converter has to be screened and properly fixed down according to the European Council Directive
 "Electro-magnetic Compatibility"
 - EMC - 2004/108/EC -
- The power and current range of the Frequency Converter have to be selected according to the full-load amperage given on the Motorized Pulley data plate.
- Do not undersize the conveyor drive. Make certain the conveyor drive provides enough belt pull at each end of the desired belt speed range. Remember that power (kW) is linearly proportional to frequency (Hz). For detailed information Refer to the technical precautions in the RULMECA Catalogue.

NOTICE

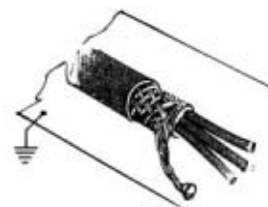

x) Capacitors (For Single Phase Motors):

- Each single phase Motorized Pulley requires an appropriate capacitor. For models 138E and 165E Start & RUN capacitors are supplied with the Pulley. Detailed information available on request. Using other than the specified RUN capacitors and a current dependent switching relays may damage the motor and voids product warranty.
- The RUN capacitors must be permanently connected to the motor, as shown on the connection diagrams.
- RULMECA single-phase motors are "permanent split phase motors". Each motor is supplied with two windings. They are designed so that an appropriately sized capacitor connected to one of the windings will start the motor rotating.
- Starting torque is limited to 70% of full running torque if used without starting capacitor.
- It is possible to increase starting torque to 100% by adding a second appropriately sized capacitor (START capacitor) to the circuit. Note that this circuit must be designed to drop the starting capacitor out of the circuit after the motor has reached its nominal speed. Contact RULMECA for more information on how to run single-phase motors using START and RUN capacitors.

y) Maintenance:

- Normally Motorized Pulleys are maintenance free and require no specific attention during their operation. They are ready for operation immediately after connection to the power supply.
- **If repair or maintenance is required, the Motorized Pulley has to be disconnected from the supply before the terminal box can be opened. Turn the electrical power off at the electrical panel board (circuit breaker or fuse box) and lock or tag the panel board door to prevent someone from turning on power while you are working on the unit. Failure to do so could result in serious electrical shock, burn or possible death**
- During a test run, the shaft ends must be correctly fixed to the support frame, and suitable guarding must be provided around the rotating parts, for the protection of all personnel.
WARNING: DO NOT operate without guards in place. Failure to follow these instructions could result in death or serious injury.

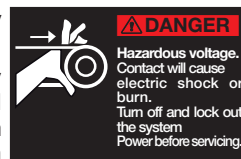

z) After Sales Service

- Always contact your local authorized Rulmeca service centre or distributor for aftermarket service or please refer to nearest Rulmeca distributor listed on the back of our catalogue. Alternatively please refer to www.rulmeca.com.



aa) Wiring Diagrams

- Please refer to pages 98-100.

NOTICE

bb) Non-Belt, Partial Belt, Modular Belt

- Special Motorized Pulley designs are available for “non-belt, V-belt, partial belt, and modular belt” applications. See “ambient temperature section” above.
- It is essential that each special application is designed to adequately dissipate heat from the Pulley surface.
- Using a standard Motorized Pulley in one of these special applications could result in motor heat damage and **voids product warranty.**
- Contact RULMECA for assistance with these applications.

NOTICE

cc) Storage of Motorized Pulleys

During storage RULMECA Motorized Pulleys

- should be stored in a house or as a minimum covered by an awning.
- have to be protected against direct influence of the sun to secure that the sealing system **does not dry out!**
- have to be turned 180° every _ year to make sure that all internal parts are being lubricated.

If Motorized Pulleys have stored longer than 1/2 year, they have to be tested before being put into operation. Such a test should include that

- The motor winding is checked with an insulation tester
- The winding resistance is checked
- The thermal protector is checked with continuity tester
- The Pulley is connected to the power supply and runs for a minimum of 30 minutes to check that there is **NO** oil leaks – make sure that the Pulley body temperature DOES NOT exceed 70°C degree.

For safety reasons make sure that the Pulley is proper fixed to the test frame during test.

dd) Dust explosion proof motorized pulleys (ATEX 95)

- The assembly, connection and sealing of the cable for dust proof motorized pulleys marked with e.g.



II 3 D 135°C



have to be double checked to avoid any explosion in case of emergencies.

- Make sure that the IP68 cable gland will be fixed properly to the terminal box dust explosion proof motorized pulley.
- Make sure that the cable will be proper sealed inside the cable gland.

Never use a cable gland with a protection rate lower than IP65.



Explanation of the symbols:

1. This is the alert symbol. It is used to alert you to potential bodily injury hazards. Obey all safety messages that follow this symbol to avoid possible injury or death.



2. These instructions and other product accompanying literature contain information that is important to know and understand. To help recognize the information, observe these symbols.



Danger indicates an imminently hazardous situation which, if not avoided, will result in death or serious injury.



Warning indicates a potentially hazardous situation which, if not avoided, could result in death or serious injury.



Caution indicates a potentially hazardous situation which, if not avoided, may result in minor or moderate injury.



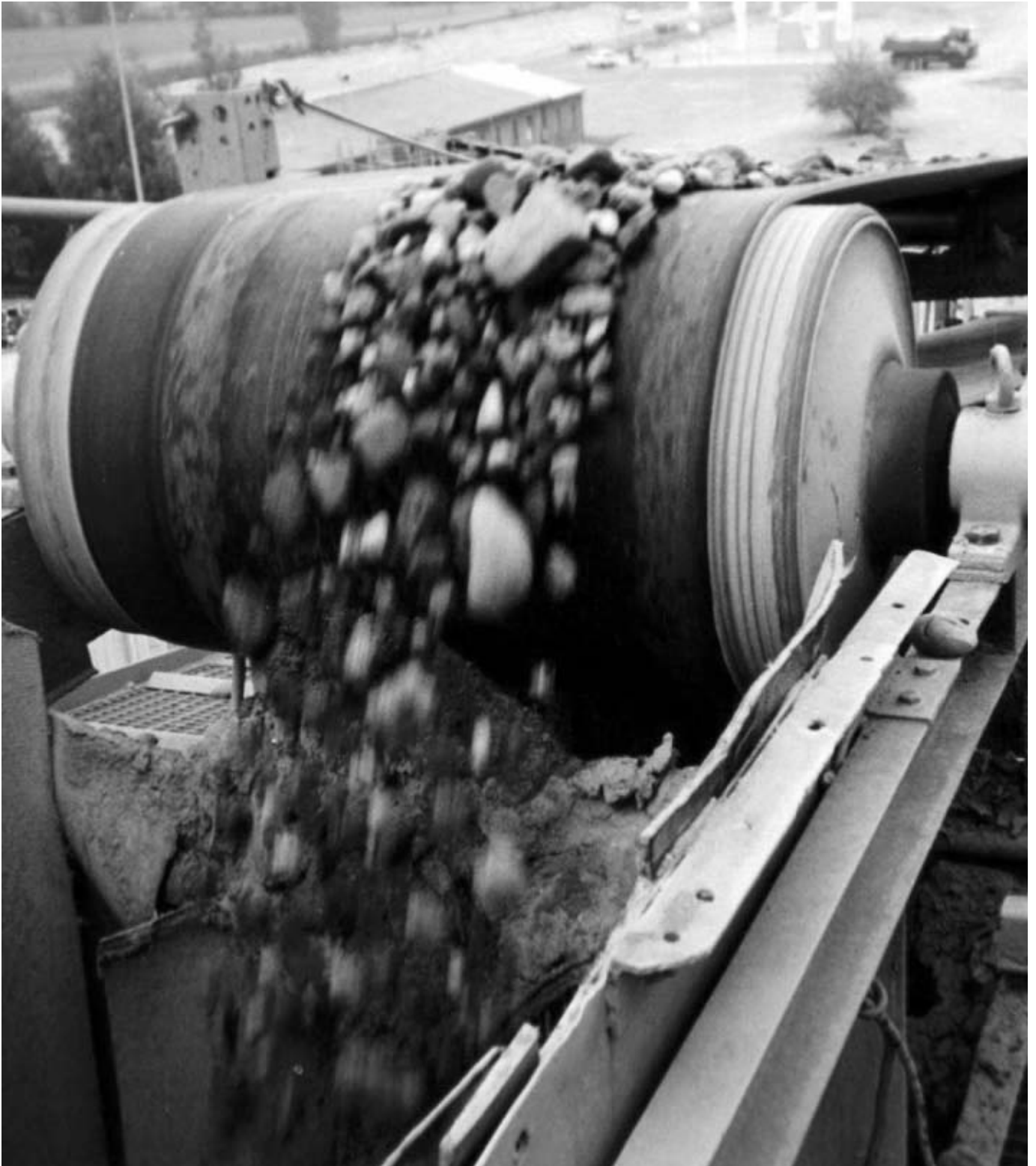

Notice indicates important information, that if not followed, may cause damages to equipment.





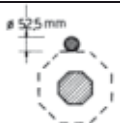
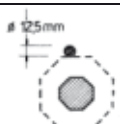
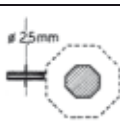
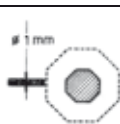

Stone & gravel application, where the drive remains reliable year after year exposed in all sorts of weather.

International Protection IP Ratings

Protection against solid bodies

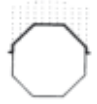
IP	Symbol	Test Definition
0		Not Protected
1		Protected against touch with the flat of the hand and large solid objects greater than 50mm
2		Protected against finger-touch and solid objects greater than 12mm.
3		Protected against solid objects greater than 2.5mm
4		Protected against solid objects greater than 1.0mm.
5		Dust-protected! Dust shall not penetrate in a quantity to interfere with the satisfactory operation of the apparatus.
6		Dust-tight

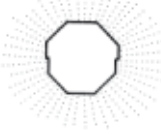
Protection of internal equipment against harmful ingress of water

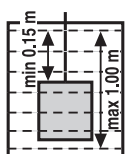
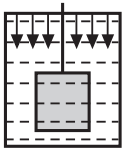
IP	Symbol	Test Definition
0		Not Protected!
1		Protected against dripping water.
2		Protected against dripping water when tilted up 15°.
3		Protected against spraying water.
4		Protected against splashing water.
5		Protected against water jets (P1 nozzle 6.3mm, water delivery rate 12.5 l/min ± 5%)
6		Protected from projections of water similar to marine swells (P2 nozzle 12.5mm, water delivery rate 100 l/min ± 5%)
7		Ingress of water in quantities causing harmful effects shall not be possible when the enclosure is temporarily (30 min.) immersed 1 meter in water under standardized conditions of pressure and time
8		Ingress of water in quantities causing harmful effects shall not be possible when the enclosure is continuously immersed in water under conditions, which shall be agreed between manufacturer and the user, but are more severe than for no. 7



Aggressive & abrasive potash application located in the desert. Features: Re-greasable IP66/67 seals, insulation class H motor, NO maintenance and operating through Frequency Converter.



Fertilizer application working round the clock!



Oil contents in liter for STANDARD Motorized Pulleys in HORIZONTAL applications

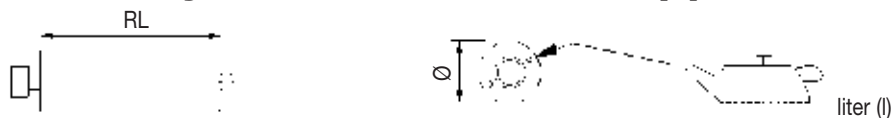

RL	138E	165E	220M & 220H		320L	320M & 320H			400L	400M	400H	500M	500H + 500L	630M	630H	800M	800H	800HD	1000HD	
			0.37-0.55kW 1.1-1.5kW	0.75kW 2.2-5.5kW		0.75k - 4.0kW	0.75k - 3.0kW	4.0 - 5.5kW												7.5kW 11.0kW
300	0.7																			
350	0.9	1.2																		
400	1.1	1.4	3.00		6.5															
450	1.3	1.6	3.50	4.00	7.0															
500	1.5	1.8	4.00	5.00	7.5	3.50	8.0	10.0	8.0											
550	1.8	2.0	4.25	5.25	8.0	3.75	8.5	10.5	9.0											
600	2.0	2.3	4.50	5.50	9.0	4.00	9.0	11.0	10.0	8.0	16.0		10.0							
650	2.2	2.5	4.75	5.75	9.5	4.25	9.5	12.0	10.5	8.5	17.0	21.0	10.5							
700	2.4	2.7	5.00	6.00	10.0	4.50	10.0	13.0	11.0	9.0	18.0	22.0	11.0							
750	2.6	2.6	5.25	6.25	10.5	5.00	10.5	13.5	12.0	9.5	19.0	23.0	11.5	27.5						
800	2.8	3.1	5.50	6.50	11.0	5.50	11.0	14.0	13.0	10.0	20.0	24.0	12.0	28.0						
850	3.0	3.3	5.75	6.75	11.5	5.75	11.5	15.0	13.5	10.5	21.0	25.0	12.5	29.0						
900	3.2	3.5	6.00	7.00	12.5	6.00	12.0	16.0	14.0	11.0	22.0	26.0	13.0	30.0						
950	3.4	3.7	6.25	7.25	13.0	6.25	13.0	17.0	15.0	11.5	23.0	28.0	14.0	32.0	51.5	61.5				
1000	3.6	3.9	6.50	7.50	14.0	6.50	14.0	18.0	16.0	12.5	25.0	30.0	15.0	34.0	53.0	64.0				
1050	3.6	4.1	6.75	7.75	14.5	6.75	14.5	18.5	16.5	13.5	27.0	31.0	15.5	36.0	54.0	66.5				
1100	3.8	4.4	7.00	8.00	15.0	7.00	15.0	19.0	17.5	14.0	28.0	32.0	16.0	38.0	56.5	69.0				
1150	4.0	4.6	7.25	8.25	16.5	7.50	16.5	20.5	19.5	14.5	29.0	34.0	17.0	40.0	59.0	71.0	126.0			
1200	4.2	4.8	7.50	8.50	18.0	8.00	18.0	23.0	21.0	15.0	30.0	36.0	18.0	42.0	60.5	73.0	128.0			
1250	4.4	5.0	7.75	8.75	19.0	8.50	19.0	24.0	22.0	15.5	31.0	37.0	18.5	43.5	63.0	74.5	130.0			
1300	4.6	5.2	8.00	9.00	20.0	9.00	20.0	25.0	22.5	16.0	32.0	38.0	19.0	45.0	64.5	76.0	132.0	130.0		
1350	4.8	5.4	8.25	9.25	21.0	9.50	21.0	26.5	23.0	17.0	34.0	40.0	20.0	46.5	66.0	78.0	134.0	133.0		
1400	5.0	5.6	8.50	9.50	22.0	10.00	22.0	28.0	24.0	18.0	36.0	42.0	21.0	48.0	68.0	80.0	135.0	135.0	240.0	
1450	5.1	5.8	8.75	9.75	23.0	10.50	23.0	29.0	25.0	18.5	37.0	43.0	21.5	49.0	70.0	82.0	137.5	138.0	243.0	
1500	5.3	6.0	9.00	10.00	24.0	11.00	24.0	30.0	25.5	19.0	38.0	44.0	22.0	50.0	72.0	84.0	140.0	140.0	245.0	
1550	4.8	5.8	9.25	10.25	25.0	12.00	25.0	31.5	26.0	19.5	39.0	46.0	23.0	51.5	74.0	86.0	142.5	143.0	248.0	
1600	5.0	6.0	9.50	10.50	26.0	13.00	26.0	33.0	27.0	20.0	40.0	48.0	24.0	53.0	76.0	88.0	145.0	145.0	252.0	
1650	5.1	6.2	10.00	11.00	27.0	14.00	27.0	34.0	28.0	20.5	41.0	50.0	25.0	54.0	79.0	90.0	147.5	148.0	255.0	
1700	5.3	6.4	11.50	11.50	28.0	15.00	28.0	35.0	28.5	21.0	42.0	52.0	26.0	55.0	80.5	92.0	150.0	150.0	258.0	
1750	5.5	6.6	12.00	12.00	29.0	16.00	29.0	36.0	29.0	22.0	44.0	54.0	27.0	56.5	82.0	94.0	152.5	153.0	262.0	
1800	5.6	6.8	13.00	13.00	30.0	17.00	30.0	37.0	30.0	23.0	46.0	56.0	28.0	58.0	84.0	96.0	155.0	155.0	265.0	
1850	5.8	7.0	13.50	13.50	30.5	18.00	30.5	38.5	31.0	23.5	47.0	60.0	30.0	59.5	86.0	98.0	157.5	158.0	268.0	
1900	5.9	7.1	14.00	14.00	31.00	19.0	31.0	40.0	32.0	24.0	48.0	64.0	32.0	61.0	88.0	100.0	160.0	160.0	272.0	
1950			7.3	15.50	14.50	31.5	20.0	31.5	40.5	33.0	24.5	49.0	68.0	34.0	61.5	90.0	102.0	162.0	162.0	275.0
2000			7.5	15.00	15.00	32.0	21.0	32.0	41.0	34.0	25.0	50.0	70.0	36.0	62.0	92.0	104.0	164.0	164.0	278.0

Please Note! The given oil contents are valid for STANDARD un-lagged Motorized Pulleys only!
 For SPECIAL options the oil contents might deviate severely. Therefore, ALWAYS use the given oil quantity listed on the MOTOR DATA PLATE!

Oil contents in liter (l) for SPECIAL constructions in VERTICAL applications

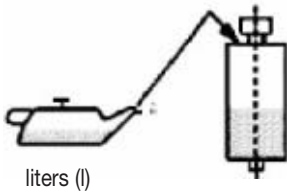

Type	Amount of oil in liter (l)	Specifications
138E	1.4	Electrical connection to be located at the top
165E	3.0	
220M	10.0	
220H	10.0	
320L	25.0	
320M	25.0	
320H	25.0	
400L	40.0	

Please Note!

- The given oil contents are valid for STANDARD un-lagged Motorized Pulleys only!
- For SPECIAL options the oil contents might deviate severely.
- Therefore, ALWAYS use the given oil quantity listed on the DATA PLATE!

Special Version Please contact Rulmecca

Please note the indicated oil fill quantities are valid only for STANDARD execution Motorized Pulleys. With SPECIAL executions it is possible that the oil quantities vary. In such a case the given quantities on the motor data label is the valid indication

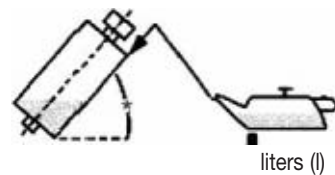

Product range Motorized Pulleys	Non-horizontal installation between	Typical application	Precautions
138E & 165E 220M & 220H 320L, 320M & 320H 400L	5° - <90°	Magnetic Separations	Special design & special amount of oil! Please contact Rulmecca before placing the order.

Oil Types

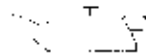

Type of Motorized Pulley	IEC34 Ins.Class	Ambient Temp.	ISO 3498 - DIN 51519	DIN 51517	Castrol	BP	Esso Mobil	Shell	Texaco
Ø138-800 Standard	F	-25°C+40°C	CC ISOVG 150	CLP ISOVG 150	ALPHA SP 150	ENERGOL GR-XP 150	MOBILGEAR 600 XP 150	OMALA 150	MEROPA 150
Ø138-1000 Synthetic option	F	-25°C+40°C	CC ISOVG 220	CLP ISOVG 220	ALPHA- SYN T 220		SHC 630V 220		
Ø138-1000 Standard	H	-25°C+40°C	CC ISOVG 220	CLP ISOVG 220	ALPHA- SYN T 220		SHC 630V 220		
Ø138-800 Food Grade	F & H	-30°C+40°C	CC ISO VG 220	Complies with Food Additive regulation 12 CPR				Shell Cassida GL220	

Synthetic oil is **not only** used for Insulation Class H, but also

- To reduce wear of gears and bearings and consequently increase the service life of the Pulley
- To reduce noise
- To reduce oil damages due to overheating in connection with certain options, types of rubber lagging etc. etc.

Connection Diagrams for Motorized Pulleys 138E - 400L

Cable Connection

Cable wires with numbers

T1 & T2 = Thermal Protector
 EB = Electromagnetic brake
 B1 & B2 = EB

01

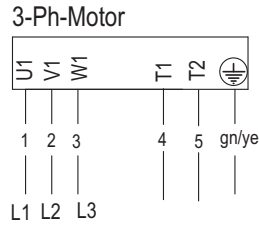

02

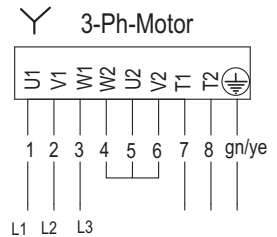
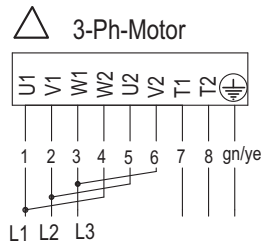

03

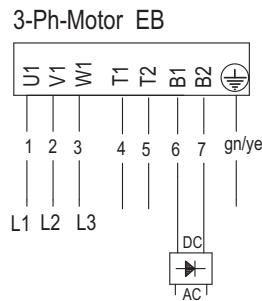

04

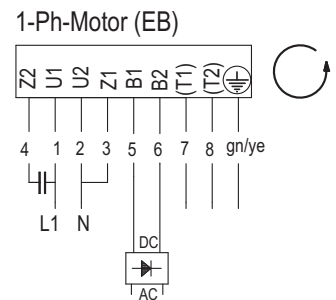
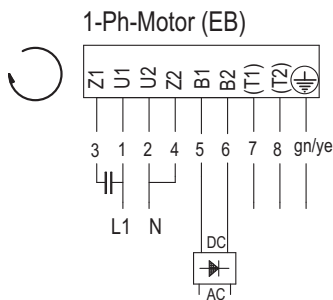

05

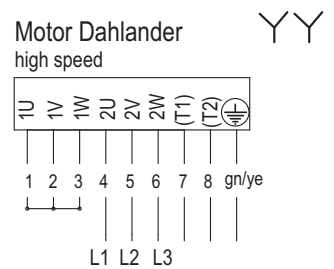
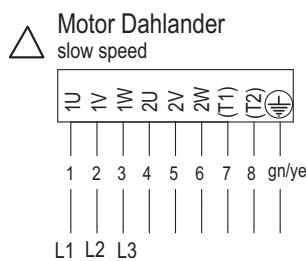

Connection Diagrams for Motorized Pulley with Compact Terminal Box and WAGO-Clamp 138E - 400L & power ≤ 4.0 kW

Assembly instruction

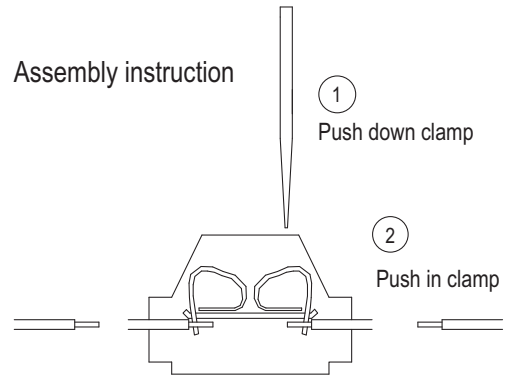

Characters in brackets for 2 stage gearbox!

EB = Electromagnetic brake

Clamps B1 and B2 are for standard unassigned

- RD = Red
- YE = Yellow
- BK = Black
- GY = Grey
- BU = Blue
- GN = Green
- WH = White
- BN = Brown
- T1 & T2 = Thermal Protector
- B1 & B2 = Electromagnetic Brake

01

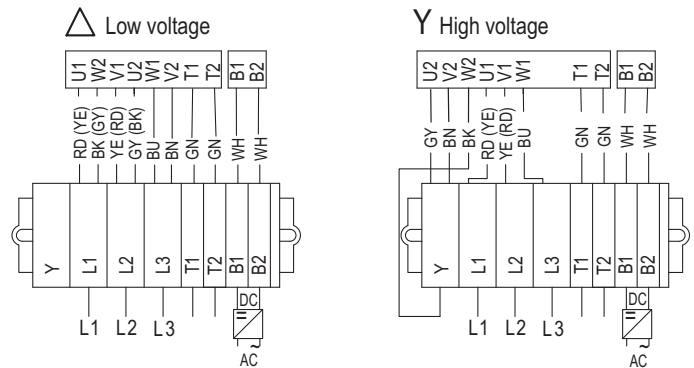

02

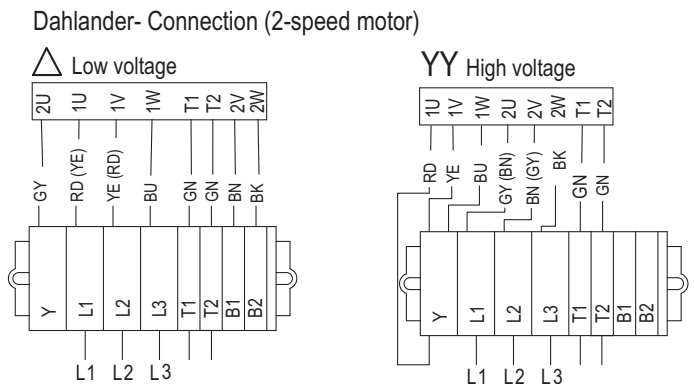

03

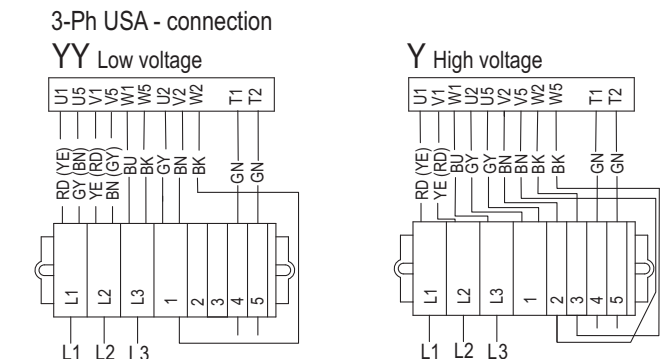

04

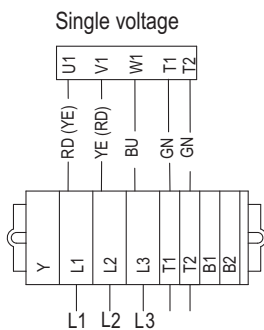

Note: check the star (U2/V2/W2) before reconnection!

External Connection Diagrams for Motorized Pulleys 5.5 kW 250 kW

Low voltage - Δ

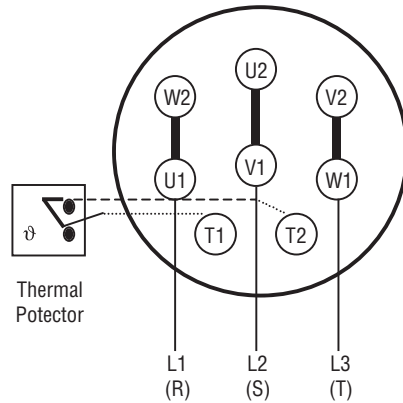

High voltage - Y

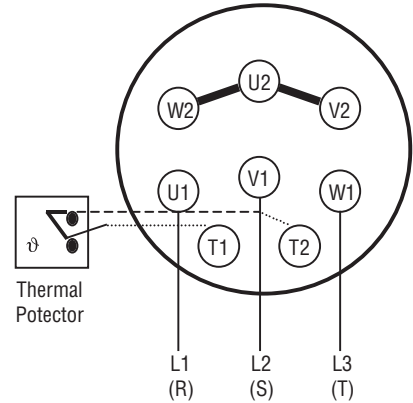

Terminal Box 5.5 kW - 132 kW

Electromagnetic Brake Execution

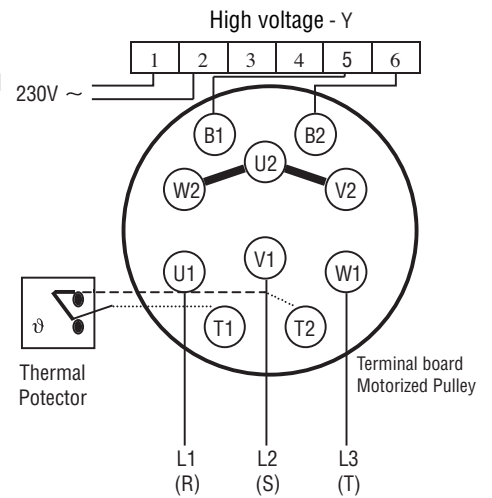
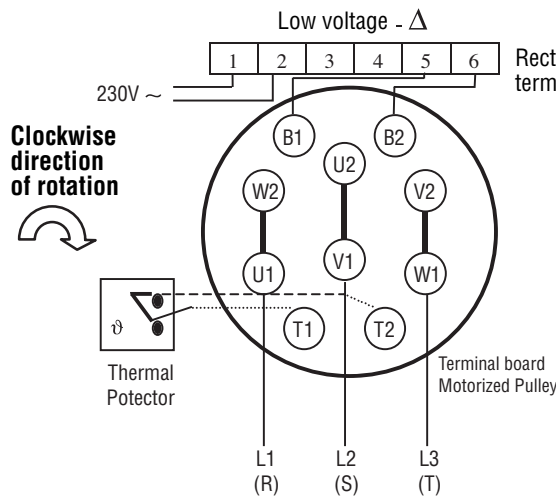

3-phase single voltage 5.5kW - 250kW

USA - Execution

Low voltage - YY

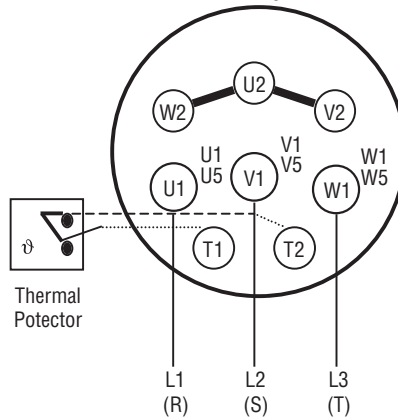
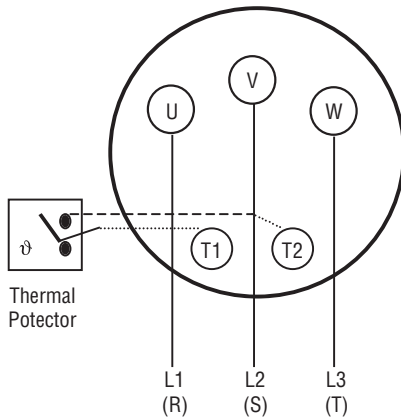

High voltage - Y

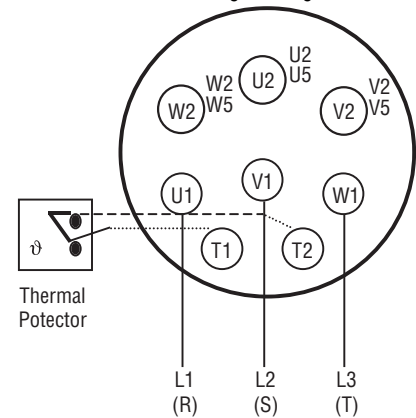

OPTIONAL EXTRAS - Motorized Pulley 138E & 165E and 220M - 1000HD

Specification	Types	138E	165E	220M & 220H	320L	320M & 320H	400L	400M & 400H	500L & 500M	500H	630M	630H	800M	800H	800HD	1000HD
Total stainless steel option		X														
Total stainless steel option AISI 304 range	TS9N Re-greassable labyrinth seals!		X													
Total stainless steel option AISI 304 range	TS10N Standard seals!			X												
Semi-rust-free option	TS11N or TS11 Re-greassable labyrinth seals!			TS11N	TS11N	TS11N	TS11N	TS11N	TS11	TS11	TS11	TS11	TS11	TS11		
Semi-rust-free option	TS12N or TS12 Standard seals!			TS12N	TS12N	TS12N	TS12N	TS12N	TS12	TS12	TS12	TS12	TS12	TS12	TS12	TS12
Food grade oil & grease - FDA & USDA recognized - available on request		X	X	X	X	X	X	X	X	X	X	X	X	X	X	X
Dust explosion proof motorized pulleys - ATEX 95 - Zone 22 - for applications handling of dusty grain etc. According to European Directive 94/9/EC.		On request!	On request!	On request!	On request!	On request!	On request!	On request!	On request!	On request!	On request!	On request!	On request!	On request!	On request!	On request!
TOTAL acid resistant stainless steel option - AISI 316		X	X	X	X	X	X	X	X	X	X	X	X	X	X	X
Re-greassable labyrinth seals - mild steel																
Black rubber lagging - STANDARD specifications:																
- Smooth lagging - Hardness 60 ±5 Shore A				5 mm	5/8 mm	5/8 mm	8 mm	8 mm	8 mm	8 mm	10 mm	10 mm	10 mm	10 mm	10 mm	10 mm
- Diamond lagging - Hardness 60 ±5 Shore A				6 mm	6/8 mm	6/8 mm	8 mm	8 mm	8 mm	8 mm	10 mm	10 mm	10 mm	10 mm	10 mm	10 mm
White smooth rubber lagging (FDA). Oil, fat & grease resistant				X	X	X	X	X	X	X	X	X	X	X	X	X
SPECIAL lagging available on request - e.g. hot vulcanized, ceramic etc.				X	X	X	X	X	X	X	X	X	X	X	X	ceramic
Single phase motors available on request		X	X	X	X	X	X	X	X	X	X	X	X	X	X	X
Electromagnetic brake		X	X	X	X	X	X	X	X	X	X	X	X	X	X	X
External brake shaft for connection to mechanical brake	Min. RL dimensions increases by (mm)															
Mechanical backstop - 400M/500L from RL750 mm & 400H/500M from RL800 mm	Min. RL dimensions increases by (mm)	X	X	X	X	X	X	X	X	X	X	X	X	X	X	X
Modified for vertical mounting																
Modified for mounting between 5° - ≤90° - e.g. for magnetic separators																
Insulation class F - Allowable ambient temperature: -25°C→+40°C		Std.	Std.	Std.	Std.	Std.	Std.	Std.	Std.	Std.	Std.	Std.	Std.	Std.	Std.	Std.
Insulation class H with synthetic oil		X	X	X	X	X	X	X	X	X	X	X	X	X	X	Std.
SPECIAL motors for applications with NO belt contact																
Low noise drives for noise sensitive areas		X	X	X	X	X	X	X	X	X	X	X	X	X	X	X
Parallel shell		X	X	X	X	X	X	X	X	X	X	X	X	X	X	X
Thermal protector		Std.	Std.	Std.	Std.	Std.	Std.	Std.	Std.	Std.	Std.	Std.	Std.	Std.	Std.	Std.
IP66/67 Compact aluminium terminal box		Std.	Std.	Std.	Std.	Std.	Std.	Std.	Std.	Std.	Std.	Std.	Std.	Std.	Std.	Std.
IP66/67 Compact stainless steel - AISI 304 or 316 range - terminal box		X	X	≤4.0 kW	≤4.0 kW	≤4.0 kW	≤4.0 kW	≤4.0 kW	≤4.0 kW	≤4.0 kW	≤4.0 kW	≤4.0 kW	≤4.0 kW	≤4.0 kW	≤4.0 kW	≤4.0 kW
IP66/67 Larger powder coated aluminium terminal box - food grade approved				Std.	Std.	Std.	Std.	Std.	Std.	Std.	Std.	Std.	Std.	Std.	Std.	Std.
IP66/67 cast iron terminal box painted yellow				≥5.5 kW	≥5.5 kW	≥5.5 kW	≥5.5 kW	≥5.5 kW	≥5.5 kW	≥5.5 kW	≥5.5 kW	≥5.5 kW	≥5.5 kW	≥5.5 kW	≥5.5 kW	≥5.5 kW
Straight or elbow connector with flying lead		X	X	≤4.0 kW	≤4.0 kW	≤4.0 kW	≤4.0 kW	≤4.0 kW	≤4.0 kW	≤4.0 kW	≤4.0 kW	≤4.0 kW	≤4.0 kW	≤4.0 kW	≤4.0 kW	≤4.0 kW
Straight connector with flying lead - Stainless steel - AISI 304 range -		X	X	≤4.0 kW	≤4.0 kW	≤4.0 kW	≤4.0 kW	≤4.0 kW	≤4.0 kW	≤4.0 kW	≤4.0 kW	≤4.0 kW	≤4.0 kW	≤4.0 kW	≤4.0 kW	≤4.0 kW
Shaft sealing system - degree of protection IP66/67 (EN60034-5)		Std.	Std.	Std.	Std.	Std.	Std.	Std.	Std.	Std.	Std.	Std.	Std.	Std.	Std.	Std.
Screened cables - a MUST together with Frequency Converters		X	X	X	X	X	X	X	X	X	X	X	X	X	X	X
Euro voltage (3x220-240V / 380-415V 50 Hz) with +/-10% tolerance - DIN IEC 38 or (3x380-400V / 660-690V 50 Hz) with +/-10% tolerance - DIN IEC 38		Std.	Std.	X	X	X	X	X	X	X	X	X	X	X	X	X
3-phase single voltage (3x400V) or (3x690V) 50 Hz with +/-10% tolerance - DIN IEC 38		X	X	X	X	X	X	X	X	X	X	X	X	X	X	X
Special voltages - 50 and/or 60Hz	Please specify!	X	X	X	X	X	X	X	X	X	X	X	X	X	X	X
CSA approved motors - available on request only!		X	X	X	X	X	X	X	X	X	X	X	X	X	X	X

X = Optional extra's 0 = An option with certain limitations. Please refer to Technical precautions pages 78-88! Std. = Fitted as standard



AFRICA

SOUTH AFRICA

MELCO Conveyor Equipmēt
Cnr. Hertzog & Jack Pienaar Street
Germiston South Ext. 7, P.O. Box 131,
1400 Germiston, South Africa
Phone:+27 11 255 1600
Fax: +27 11 825 3592
Web: www.melcoconveyors.com
email: conveyors@melco.co.za

ASIA

CHINA

RULMECA (TIANJIN) Co. Ltd.
D1-2 & D1-4, Saida International Industrial
Park, Xiqing Economic Development
Area (XEDA)
Tianjin, People's Republic of China,
Postal Code: 300385
Phone:+86-22-2388-8628
Fax: +86-22-2388-9828
Web: www.rulmeca.com.cn
email: sales@rulmeca.com.cn

INDONESIA

RULMECA (THAILAND) CO., LTD.

Mr. Suwarno Kie
30 F, Menara Standard Chartered
Jl. Prof. Dr. Satrio Fav 164
Jakarta - 12950 Indonesia
Phone: +6221 2555 5828
Fax: +6221 5435 7958
email: suwarno.kie@rulmecaindonesia.com

ISRAEL

COMTRANS ENGINEERING Ltd.

5 Hahoma Street
Rishon le-Zion 75655, Israel
Phone:+972 3 961 9636
Fax: +972 3 961 9644
email: comtrans@comtrans.co.il

KAZAKHSTAN

RULMECA GERMANY GmbH

Representative Office
2, Pshembaev Street
141200 Ekibastus
Tel./Fax +7 71835 492 98
E-mail: baubakirova@mail.ru

JAPAN

INTERROLL (JAPAN) Co. Ltd.

302-1 Shimokuzawa
Sagamihara-shi
Kanagawa, Japan (229-1134)
Phone:+81 42 764 2677
Fax: +81 42 764 2678
email: jpn-sales@interroll.com

SINGAPORE

INTERROLL (ASIA) Pte. Ltd.

386 Jalan Ahmad Ibrahim
629156 Singapore
Phone:+65 6 266 6322
Fax: +65 6 266 6849
email: sgp-sales@interroll.com

THAILAND

RULMECA THAILAND Co. Ltd.

41/15 Moo 6, Bangchalong, Bangplee
Samutprakarn 10540 (Bangkok)
Phone:+66 2 337 0297
Fax: +66 2 337 0302,
+66 2 337 0304
Email: th-sales@rulmeca.co.th

EUROPE

BELGIUM

UVO Technologi es bvba

Rozenlei 37
B-2540 Hove Belgium
Phone:+32 3 4554322
Fax: +32 3 4543670
Mob: +32 479 820 655
email: michel@uvo.be

DENMARK

RULMECA A/S

Langebjergvænget 19D
DK - 4000 Roskilde Denmark
Phone:+45 36 776755
Fax: +45 36 776855
email: dk@rulmeca.com

FINLAND, ESTONIA, LETLAND & LITAUEN RULMECA OY

Tuusantie 1 (2. krs),
03100 Nummela - Finland
Tel. +358 922435510
Fax. +358 922435100
E-mail msarjokoski@rulmeca.com

FRANCE

PRÉCISMECA

Equipmēt de Manutenti on
Rue de La Gare - F-67700 Otterswiller
Phone:+33 3 88 71 58 00
Fax: +33 3 88 91 28 01
www.rulmeca.com
email: info.france@rulmeca.com

GERMANY

RULMECA GERMANY GmbH

Wilslebener Chaussee 12-14
D-06449 Aschersleben
Phone:+49 (0) 3473 956-0
Fax: +49 (0) 3473 956-210
Web: www.rulmeca.com
email: faa@rulmeca.com

GREECE

TECOM KOUKOULIS LTD.

Ag. Nicolaou 60 16674 Glyfada - Greece
Tel: +30-2109604101
+30-2109604102
Fax: +30-2109604100
email: tecom@otenet.gr

ITALY

RULLI RULMECA S. P. A.

Via A. Toscanini, 1
I-24011 Almè (Bergamo)
Phone:+39 035 4300 111
Fax: +39 035 545 523
Web: www.rulmeca.it
email: rulmeca@rulmeca.it

NEDERLAND

TRAMAT bv

Vlietskade 7009 - NL - 4241 WR Arkel
Phone:+31 0183 565 333
Fax: +31 0183 565 335
Web: www.Tramat.nl
email: info@Tramat.nl

NORWAY

INTERROLL A/S

Kobbervikdalen 65
N-3036 Drammen
Phone:+47 32 882600
Fax: +47 32 882610
email: n-sales@interroll.com

PORTUGAL

RULMECA DE PORTUGAL, LDA

P. Ind. do Tortosendo
Rua A Lote 15 Apartado 113
6200-823 TORTOSENDO
Phone:+351 275 330780
Fax: +351 275 330789
E-mail: rulmeca@rulmeca-interroll.pt

RUSSIA

RULMECA GERMANY GmbH

Büro Moskau:
Leninskij Prospekt 95 A
117313 Moskau
Phone/Fax: +7 499 132 37 74
+7 495 937 52 43
email: faamsk@com2com.ru

SPAIN

RULMECA ESPAÑA S. L. U.

P.I. Urvasa
C/Ripollés, 14
08130-Sta. Perpètua de la Mogoda - Spain
Phone:+34 93 544 9199
Fax: +34 93 574 4424
email: espana@rulmeca.com

SWEDEN

RULMECA A/S

Skaraborgsgatan 29A
53230 Skara Sweden
Phone: +46 511 160 27
Fax: +46 511 160 29
email: handersson@rulmeca.com

TURKEY

RULMECA TASI MA AKSAMLARI

TI CARET LI M TED SI RKETI

Akman Condominium
Đıç Bloklu Mahallesi
Muhsin Yazıcıođlu Caddesi
No : 61 Kat:13 Daire :140
06520 Balgat/ANKARA Turkey
Phone: +90 312 284 64 74
Fax: +90 312 284 64 78
E-mail: turkey@rulmeca.com

UNITED KINGDOM

RULMECA UK Ltd.

Brunel Road
Earlstrees Ind. Estate
GB-Corby, Northants NN17 4UX
Phone:+44 1536 748525
Fax: +44 1536 748535
Web: www.rulmeca.com
email: uk@rulmeca.com

NORTH & SOUTH AMERICA

BRASIL

TECTOR INDUSTRIA E COMÉRCIO

DE EQUIPAMENTOS LTDA.

Av. Novo Horizonte, 406
09060-820 - Santo André - SP Brazil
Phone:+55 11 4428-2888
Fax: +55 11 4421-9338
email: vendas@tector.com.br
Web: www.tector.com.br

CANADA

PRÉCISMECA RULMECA GROUP

75 Mason Street
Wallaceburg, ON - N8A 4L7 - Canada
Phone: +1 (519) 627-2277
Fax: +1 (519) 627-5115
E-mail: sales@precismeca.ab.ca
Web: http://www.precismeca.ab.ca

USA

RULMECA Corporation

6508 Windmill Way, Suite B
Wilmington, North Carolina - USA, 28405
Phone:+1-910-794-9294
Fax: +1-910-794-9296
Web: www.rulmecacorp.com
email: mgawinski@rulmecacorp.com

VENEZUELA

INDUSTRIAS RULMECA S.A.

Zona Industrial Municipal Norte
Calle Este Oeste Galpón 67-200
Valencia, Edo. Carabobo. Venezuela
Phone:+58-241-833.62.49
+ 58-241-833.60.97
+ 58-241-833.61.12

Fax: +58-241-832.15.17
Web: www.rulmeca.com.ve
email: rulmeca@cantv.net





Steel production from iron ore to finished products. One of the most abrasive application possible.



6° ed. MOT BU RULMECA GERMANY 03/12

BULK HANDLING

Motorized Pulleys for belt conveyors

RULMECA GERMANY GmbH - Wilslebener Chaussee 12-14 D-06449 Aschersleben
Phone: +49 (0) 3473 956-0 Fax: +49 (0) 3473 956-210 E-mail: faa@rulmeca.com Web: www.rulmeca.com