

MHS Heavy-Duty Secondary Belt Cleaner

Superior Cleaning on the Toughest Belts

The MHS Heavy-Duty Secondary Belt Cleaner was designed to deliver and maintain superior cleaning efficiency, even on the most demanding, abusive beltlines. The MHS is the new answer to tough belt cleaning problems. It delivers high-efficiency cleaning, long-lasting performance—and with low maintenance.

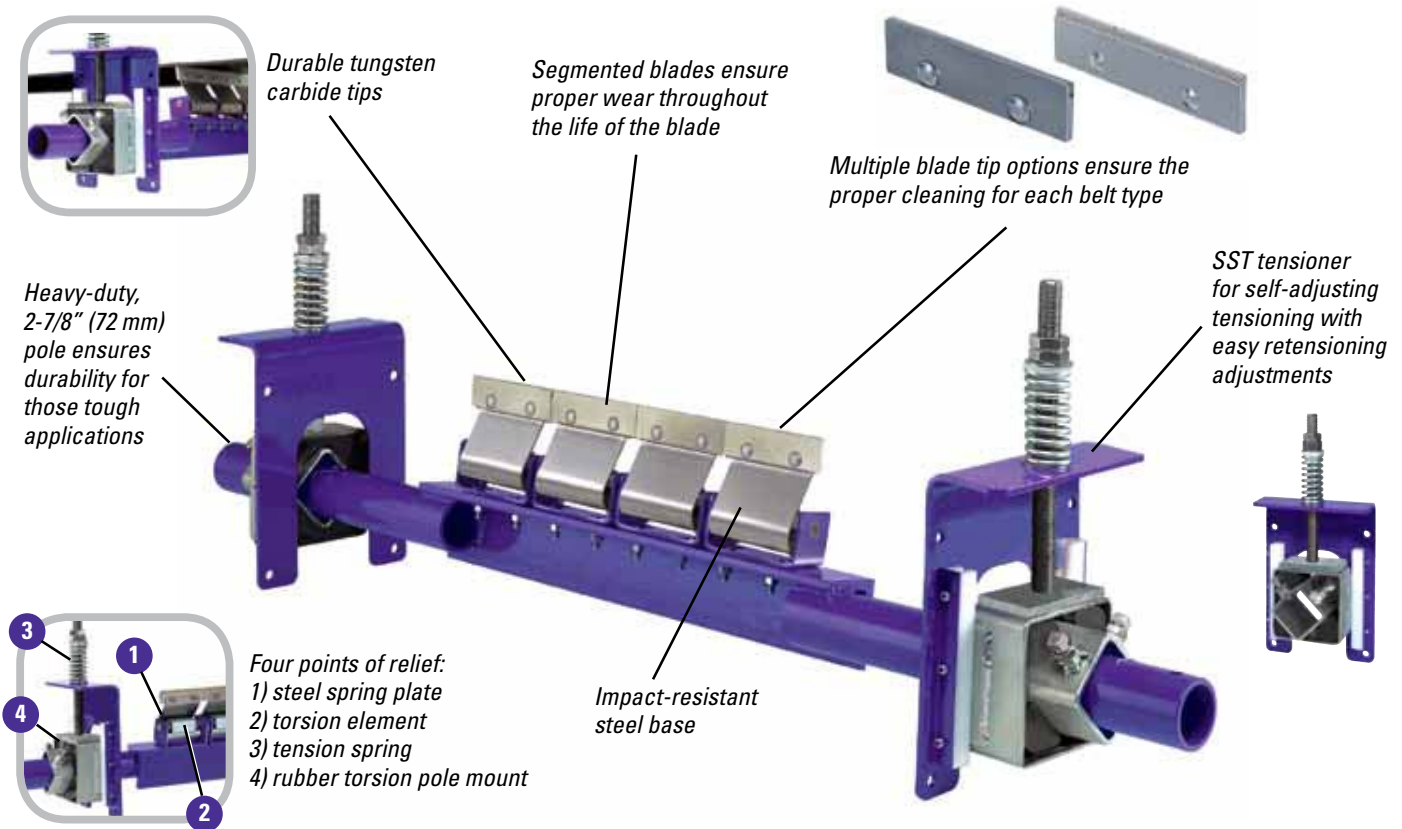

Features and Benefits

- **Cleaning efficiency of metal blades.** The thin, hard edges of the metal blades deliver high cleaning efficiency and long wear life.
- **Works with Flexco mechanical splices.** The C-Tip tungsten carbide blades are impact-resistant, and the spring cushion allows them to move away from a passing splice without damage and with minimal cleaning disruption. V-Tips can be used only on vulcanized belts.
- **A complete cleaning system.** When the MHS is teamed with the MMP precleaner the system provides maximum cleaning power for tough applications.
- **Made for mining conveyors.** Made from heavy-duty, corrosion-resistant steel, the MHS is available in sizes for belt widths from 24" to 84" (600 to 2100 mm). Additional sizes are available upon request.
- **Safe to service.** All service can be performed from a safe position at the side of the conveyor.

MHS Heavy-Duty Secondary Belt Cleaner

Specifications and Guidelines

Maximum Belt Speed

1200 FPM (6 M/sec)

Temperature Rating

-30° F to 180° F (-35° C to 82° C)

Usable Blade Wear Length

3/8" (9 mm)

Blade Material

Impact resistant, long-lasting tungsten carbide (C-Tip for mechanical fasteners, V-Tips for vulcanized belts)

Available for Belt Widths

18" to 84" (450 to 2100 mm)

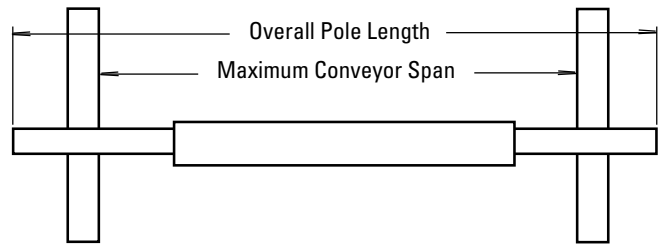

Pole Length Cleaner size + 54" (1350 mm)

Maximum Conveyor Span Cleaner size + 44" (1100 mm)

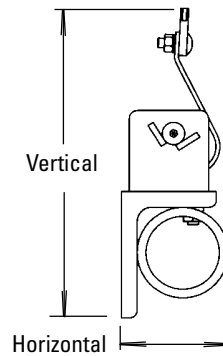

Horizontal Clearance Required
4" (100 mm)

Vertical Clearance Required
9-1/2" (238 mm)

Ordering Information

MHS HD Secondary with C-Tips

Belt Width	Ordering	Item	
in.	mm	Number	Code
24	600	MHS-24	75910
30	750	MHS-30	75911
36	900	MHS-36	75912
42	1050	MHS-42	75913
48	1200	MHS-48	75914
54	1350	MHS-54	75915
60	1500	MHS-60	75916
72	1800	MHS-72	75917
84	2100	MHS-84	76803

MHS HD Secondary with V-Tips*

Belt Width	Ordering	Item	
in.	mm	Number	Code
18	450	MHS-18V	76169
24	600	MHS-24V	76170
30	750	MHS-30V	76171
36	900	MHS-36V	76172
42	1050	MHS-42V	76173
48	1200	MHS-48V	76174
54	1350	MHS-54V	76175
60	1500	MHS-60V	76176
72	1800	MHS-72V	76177
84	2100	MHS-84V	76804

*V-Tips can be used ONLY on vulcanized belts

MHS with Air/Water Tensioner*

Belt Width	Ordering	Item	
in.	mm	Number	Code
24	600	MHS-24A	76604
30	750	MHS-30A	76605
36	900	MHS-36A	76606
42	1050	MHS-42A	76607
48	1200	MHS-48A	76608
54	1350	MHS-54A	76609
60	1500	MHS-60A**	76610
72	1800	MHS-72A**	76611
84	2100	MHS-84A**	76612

*Includes Control Box

**60", 72" and 84" models have a 3-piece pole.

MHS Reversing with C-Tips

Belt Width	Ordering	Item	
in.	mm	Number	Code
24	600	MHS-24R	76613
30	750	MHS-30R	76614
36	900	MHS-36R	76615
42	1050	MHS-42R	76616
48	1200	MHS-48R	76617
54	1350	MHS-54R	76618
60	1500	MHS-60R	76619
72	1800	MHS-72R	76620
84	2100	MHS-84R	76621

MHS Reversing with V-Tips*

Belt Width	Ordering	Item	
in.	mm	Number	Code
18	450	MHS-18RV	76646
24	600	MHS-24RV	76647
30	750	MHS-30RV	76648
36	900	MHS-36RV	76649
42	1050	MHS-42RV	76650
48	1200	MHS-48RV	76651
54	1350	MHS-54RV	76652
60	1500	MHS-60RV	76653
72	1800	MHS-72RV	76654
84	2100	MHS-84RV	76805

*V-Tips can be used ONLY on vulcanized belts

Replacement Tips

Ordering	Item
Number	Code
ICT6	74535
RSA150	73628

Tips Required Per Cleaner Size

in.	18	24	30	36	42	48	54	60	72	84
mm	450	600	750	900	1050	1200	1350	1500	1800	2100
C-Tips or V-Tips Required	3	4	5	6	7	8	9	10	12	14



2525 Wisconsin Avenue • Downers Grove, IL 60515-4200 U.S.A.

Tel: (630) 971-0150 • Fax: (630) 971-1180 • E-mail: info@flexco.com • Web: www.flexco.com

Australia: 61-2-9680-3322 • China: 86-21-33528388 • England: 44-1274-600-942 • Germany: 49-7428-9406-0
India: 91-44-4354-2091 • Mexico: 52-55-5674-5326 • Singapore: 65-6281-7278 • South Africa: 27-11-608-4180

©2011 Flexible Steel Lacing Company. 06/11. For Reorder: X2399

Authorized Distributor:

